

LER 332 - Mecânica e Máquinas Motoras

7ª Semana de Aula: Motores de Combustão Interna III

Prof.Dr. Casimiro Dias Gadanha Junior

1- Objetivos

-Conhecer a constituição e o funcionamento do Sistema de Válvulas

- Conhecer a constituição e o funcionamento do Sistema de Alimentação de combustível

Conhecer a constituição e o funcionamento do Sistema de Alimentação de ar

- Conhecer a constituição e o funcionamento do Sistema de Lubrificação

- Conhecer a constituição e o funcionamento do Sistema de Arrefecimento

2- Bibliografia

MIALHE, L.G. **Máquinas motoras na agricultura** . São Paulo: EDUSP,1980.cap.10, p.213-282: Sistemas complementares dos motores do ciclo Diesel

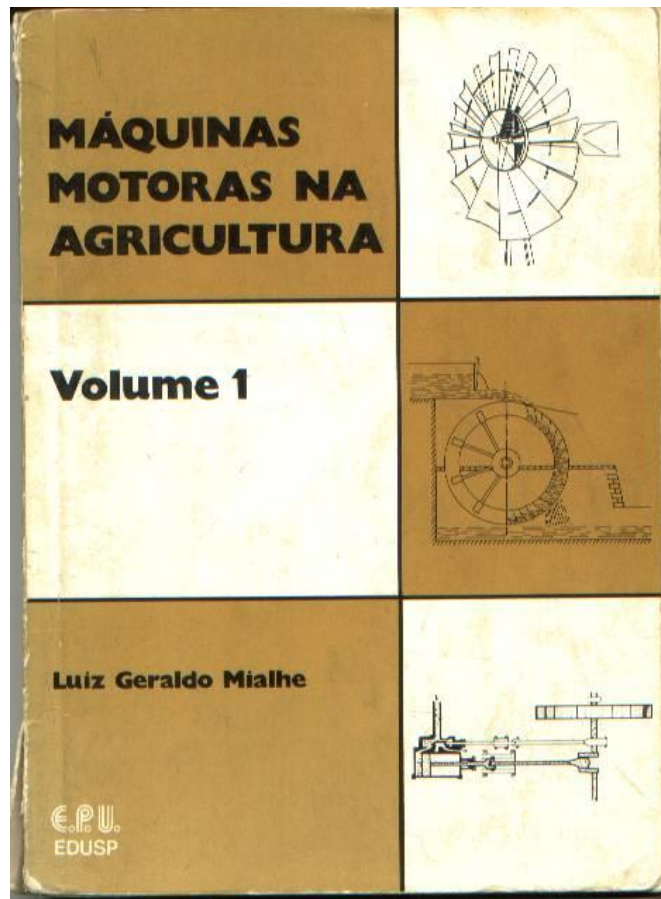

Sistema de Válvulas

FUNÇÃO

CONTROLAR A ENTRADA E SAÍDA DO FLUXO DE GASES DO INTERIOR DA CÂMARA DO CILINDRO .

INDIRETO

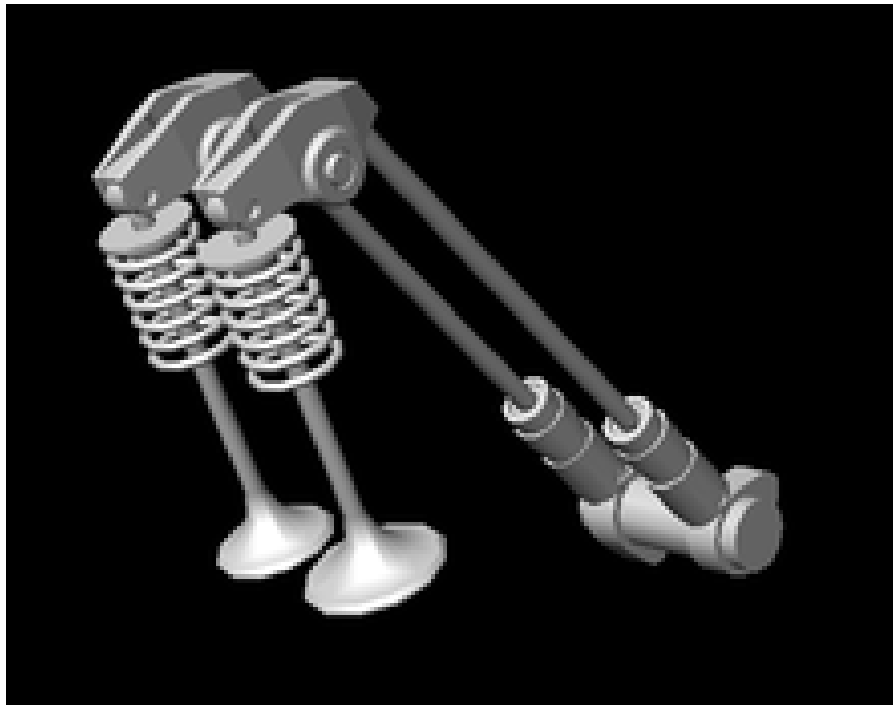

DIRETO

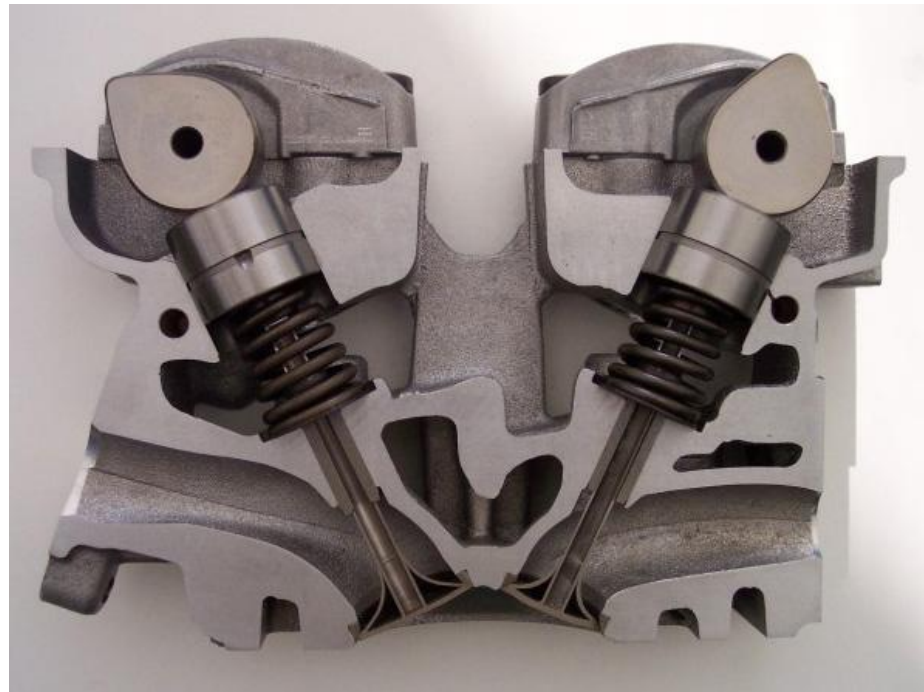

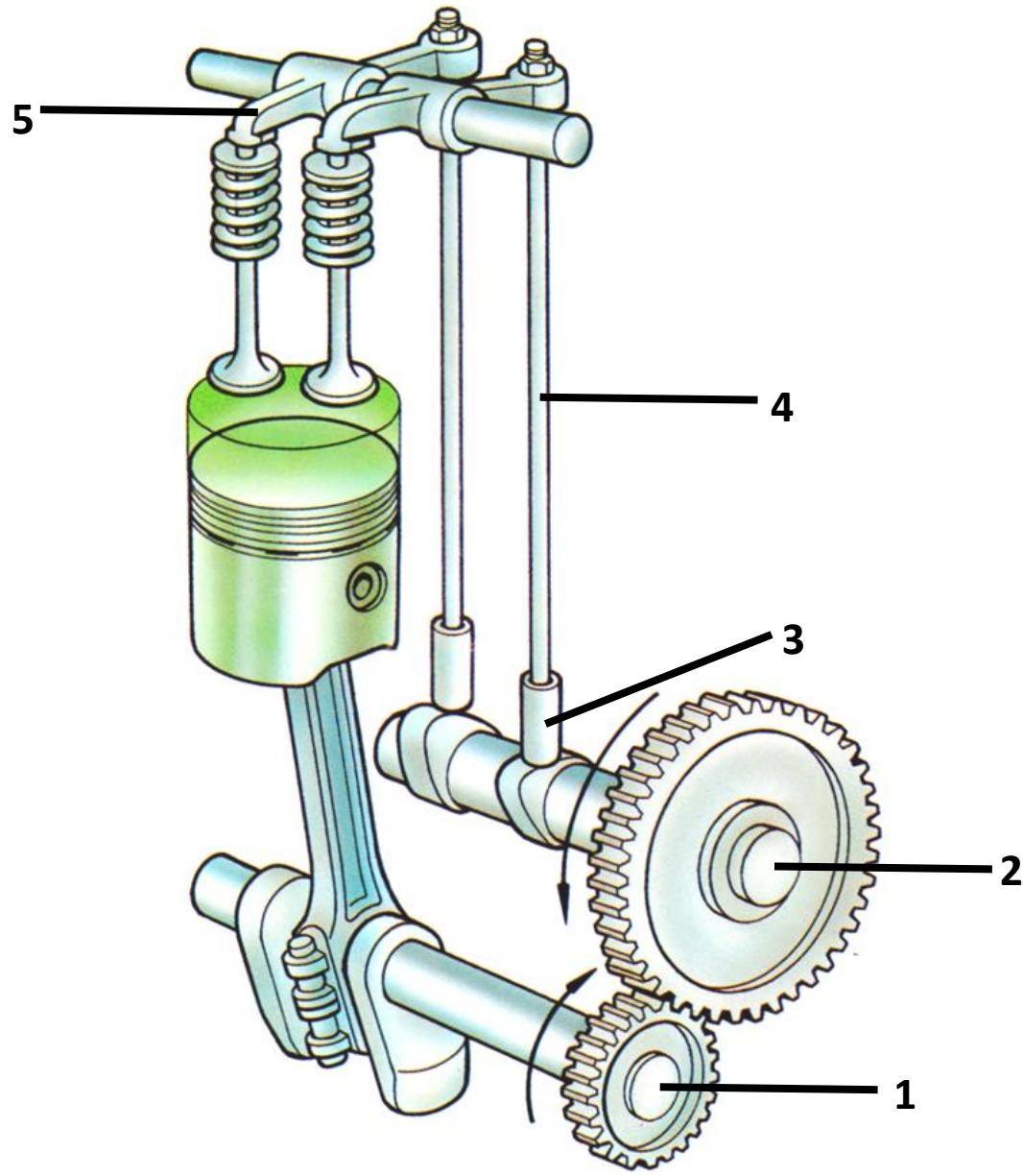

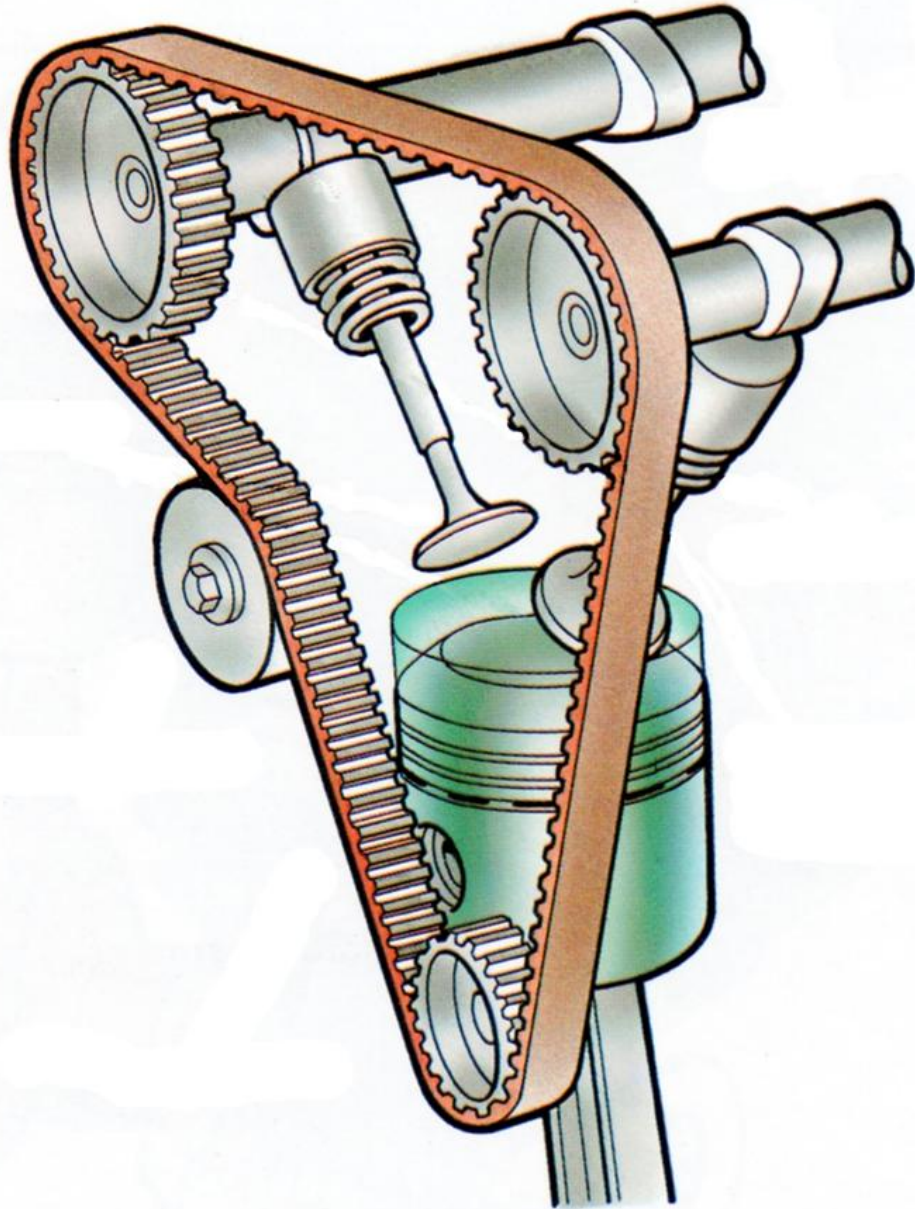

TEMPOS	DESLOCAMENTOS DOS ÊMBOLOS	ÂNGULO ADM(°)	VÁLVULAS	
			ADMISSÃO	ESCAPE
ADMISSÃO	PMS p/ PMI	0-180	ABERTA	FECHADA
COMPRESSÃO	PMI p/ PMS	180-360	FECHADA	FECHADA
EXPANSÃO	PMS p/ PMI	360-540	FECHADA	FECHADA
ESCAPE	PMI p/ PMS	540-720	FECHADA	ABERTA

FECHADA ABERTA FECHADA FECHADA FECHADA FECHADA ABERTA FECHADA

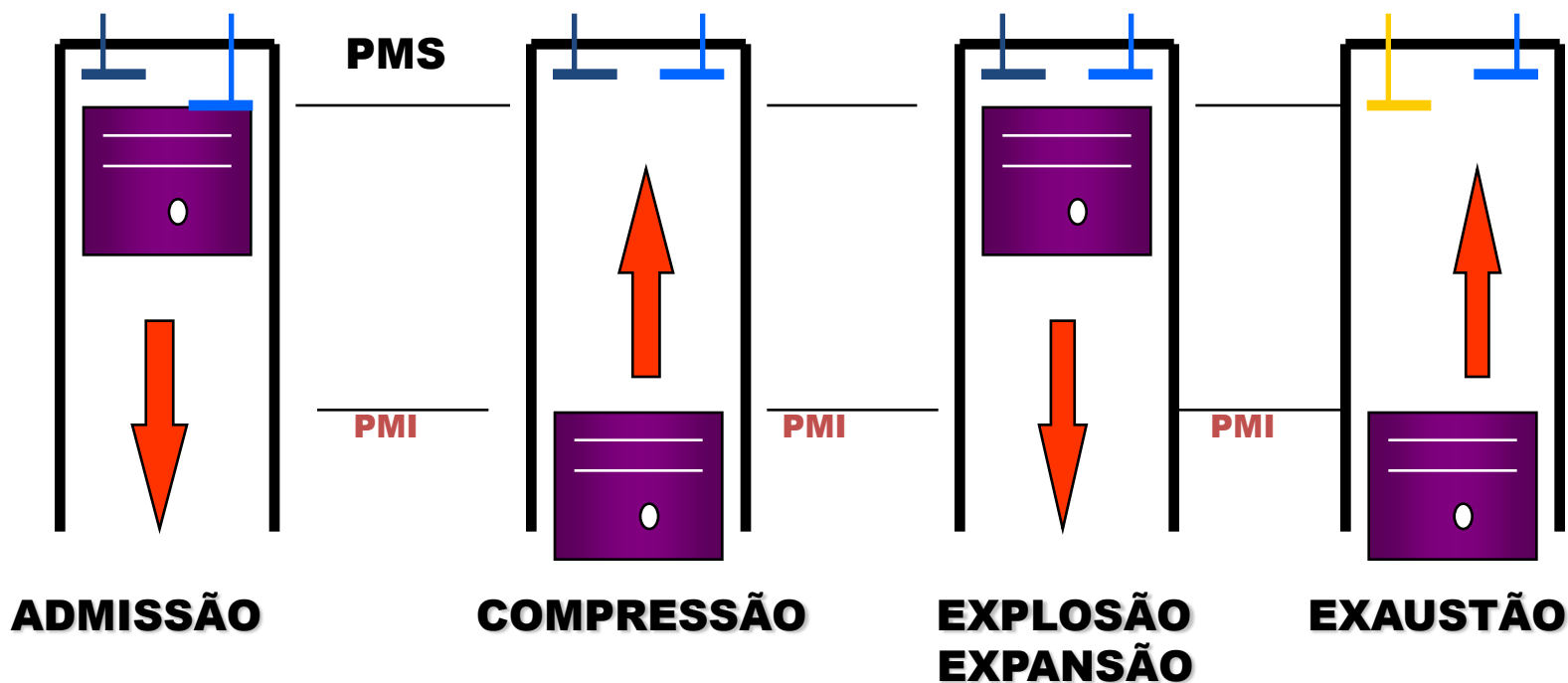

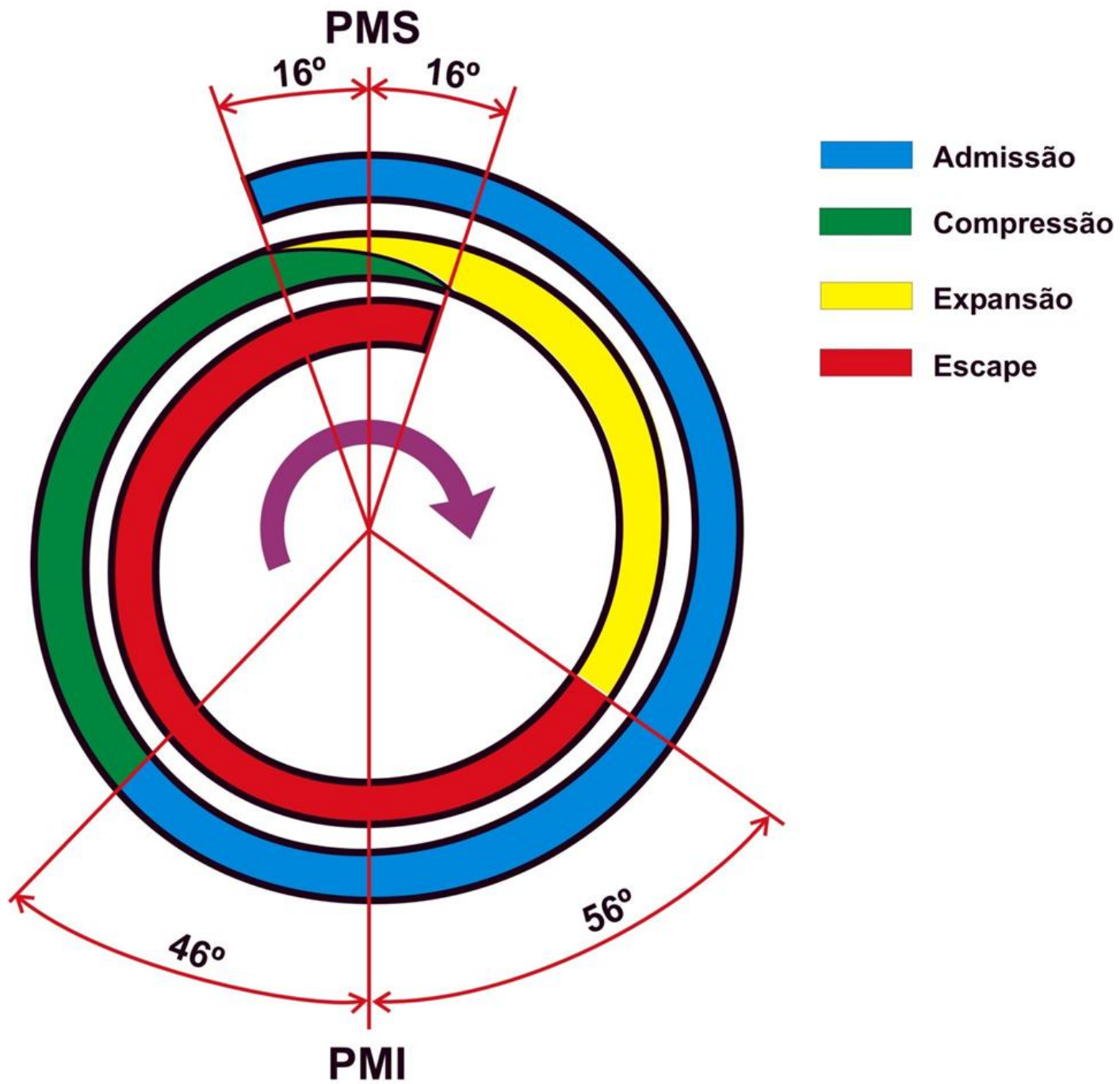

**Sistema de
Alimentação de
combustível dos
Motores de
Combustão
Interna de Ciclo
Diesel**

FUNÇÕES DO SISTEMA

- SUPRIR QUANTIDADE CORRETA DE COMBUSTÍVEL EM FUNÇÃO DA ROTAÇÃO DO MOTOR E CARGA APLICADA**
- FAZER COMBUSTÍVEL ATINGIR CÂMARA DE COMBUSTÃO ATOMIZADO**
- PERMITIR INJEÇÃO NO MOMENTO EXATO DO CICLO.**

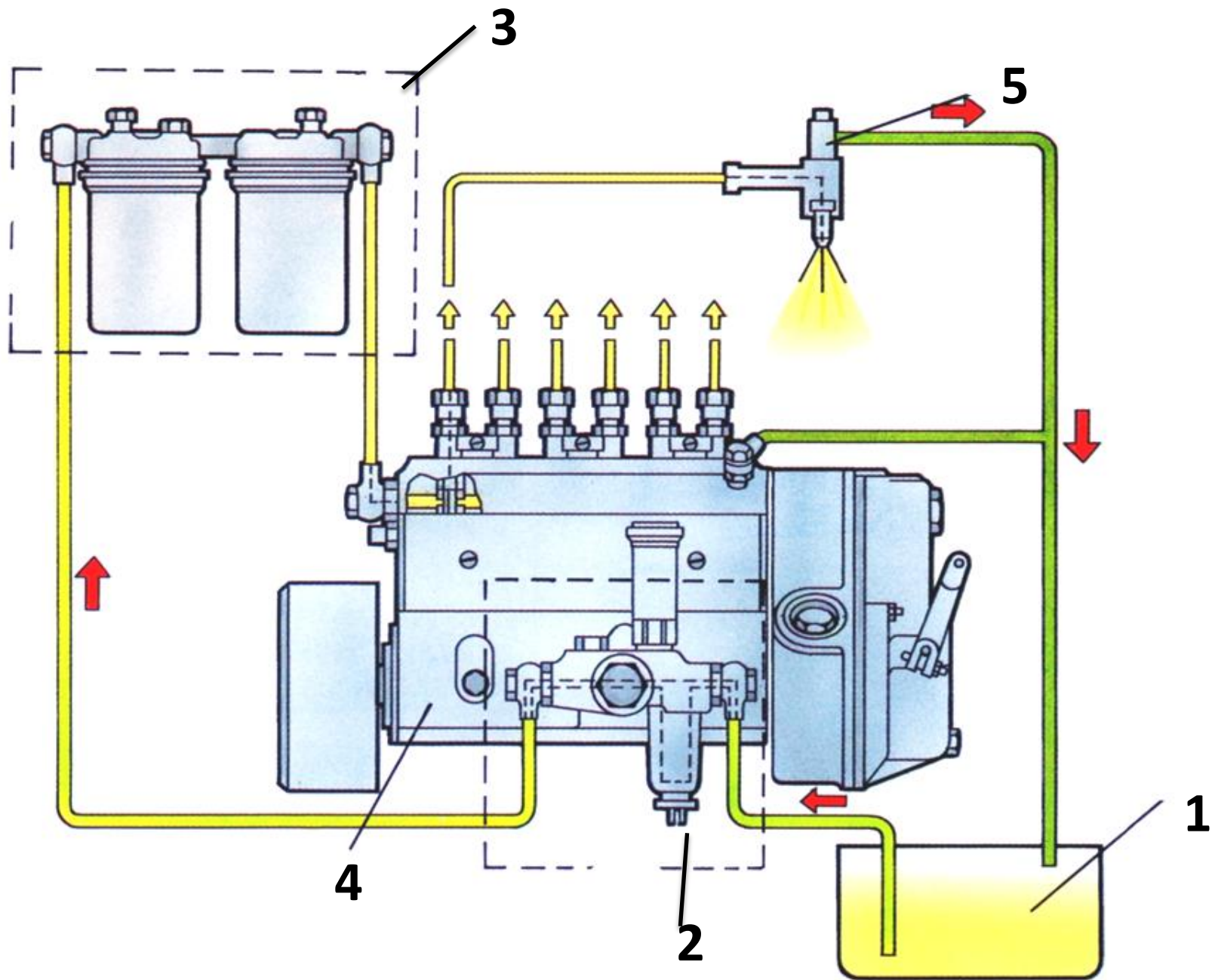

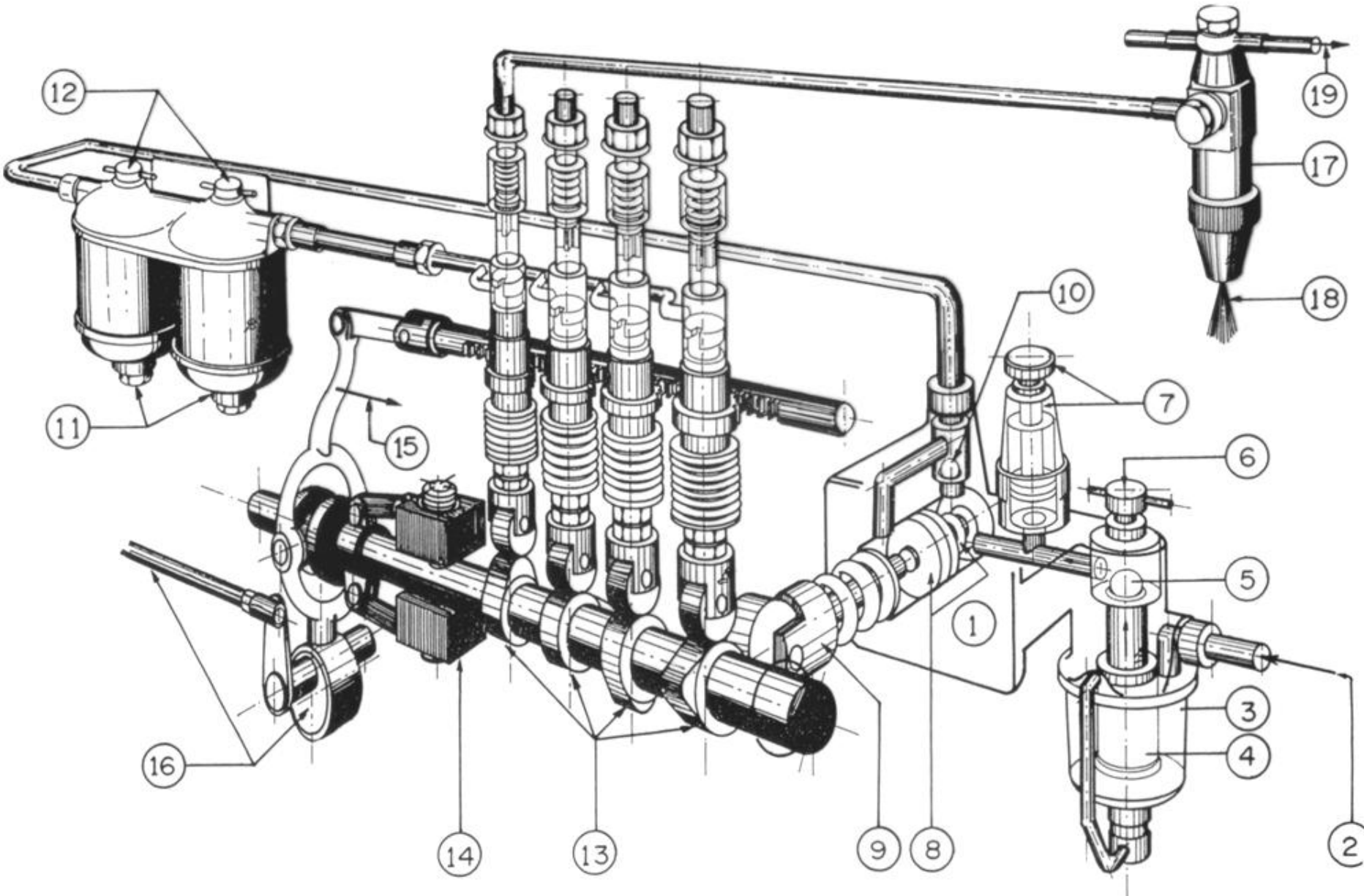

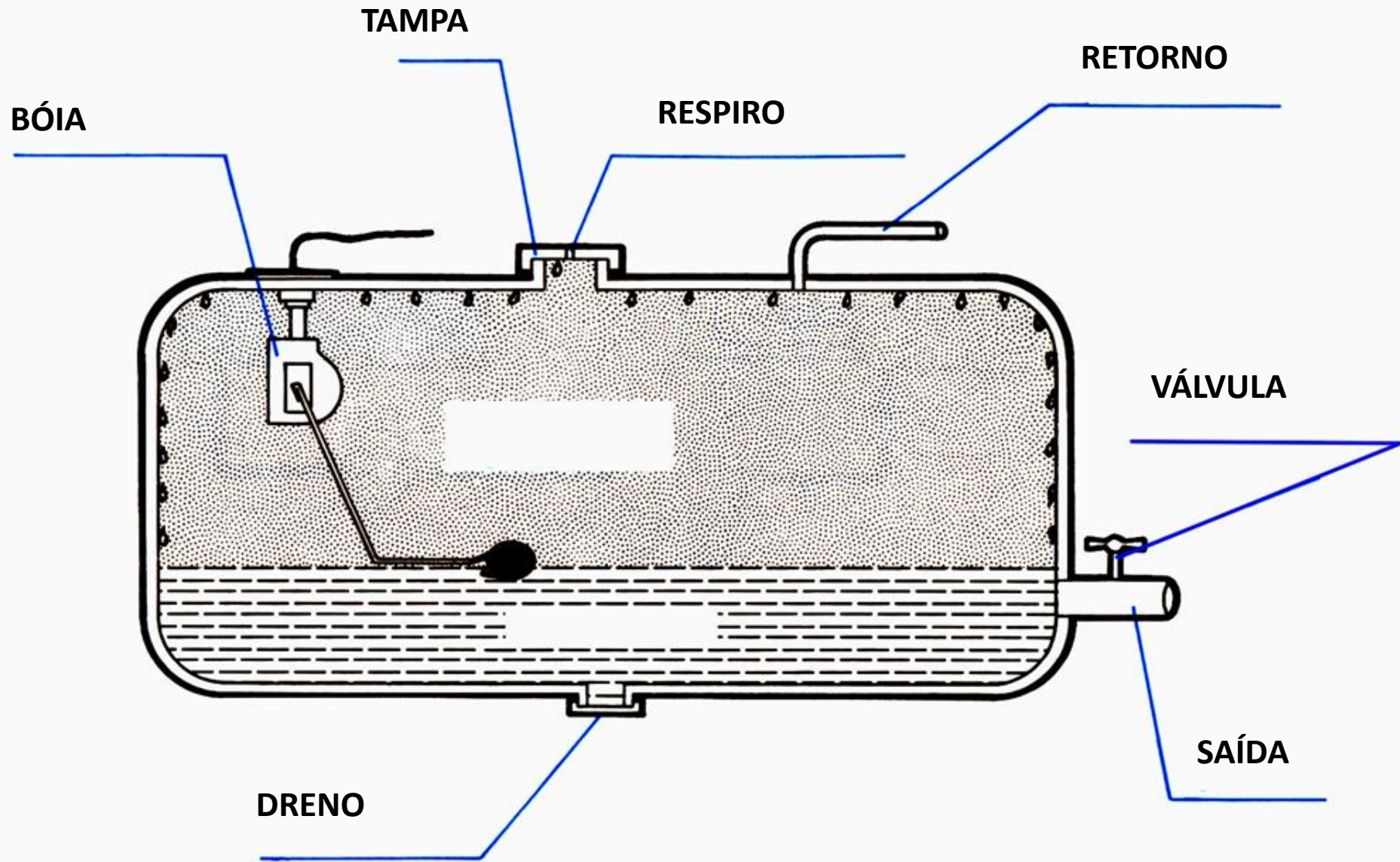

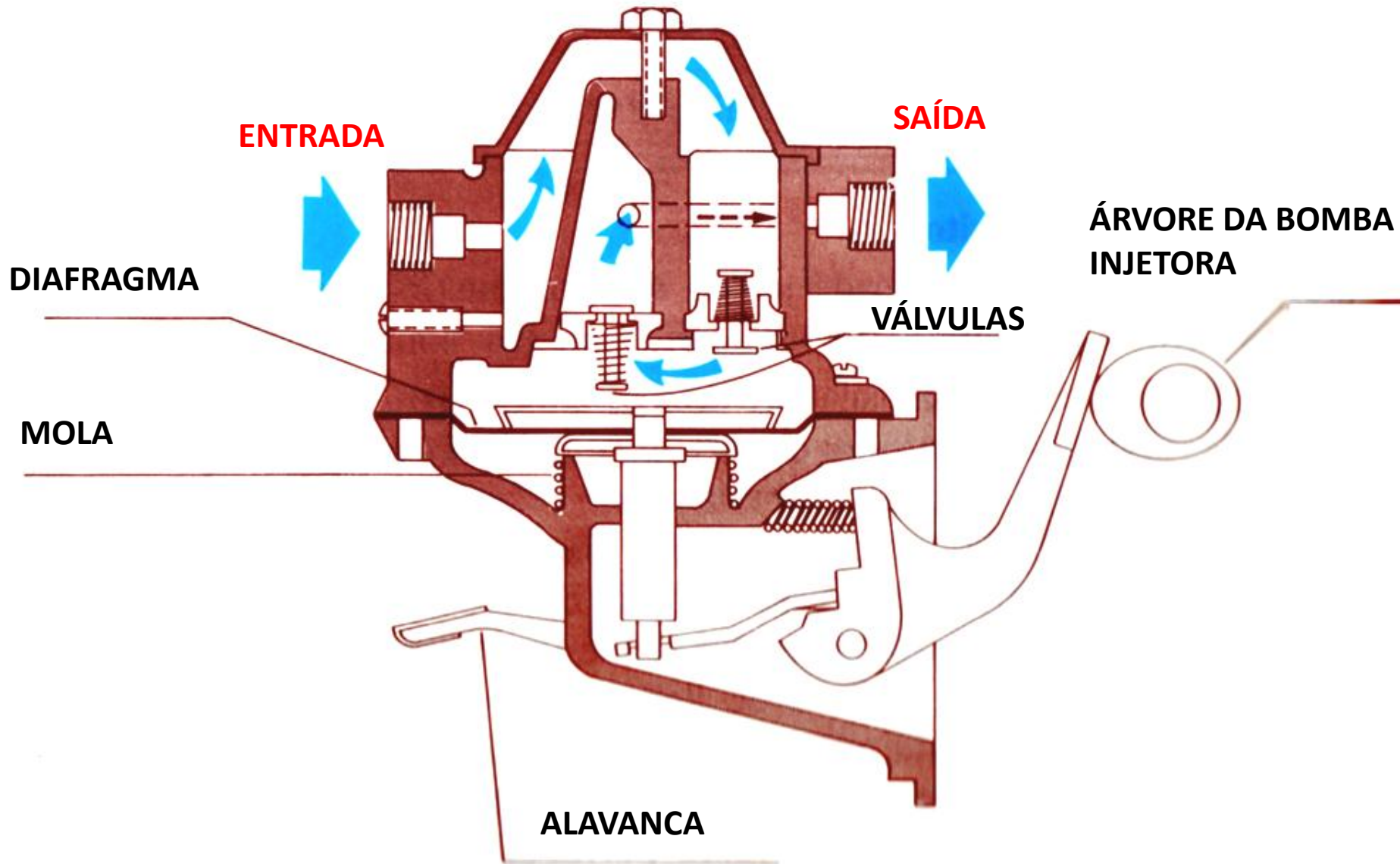

DRENO

RETENTOR DO ELEMENTO
FILTRANTE

SAÍDA

ENTRADA

RETENTOR DA
CARÇAÇA

ELEMENTO
FILTRANTE

PARAFUSO DE
FECHAMENTO

RETENTOR DO
ELEMENTO FILTRANTE

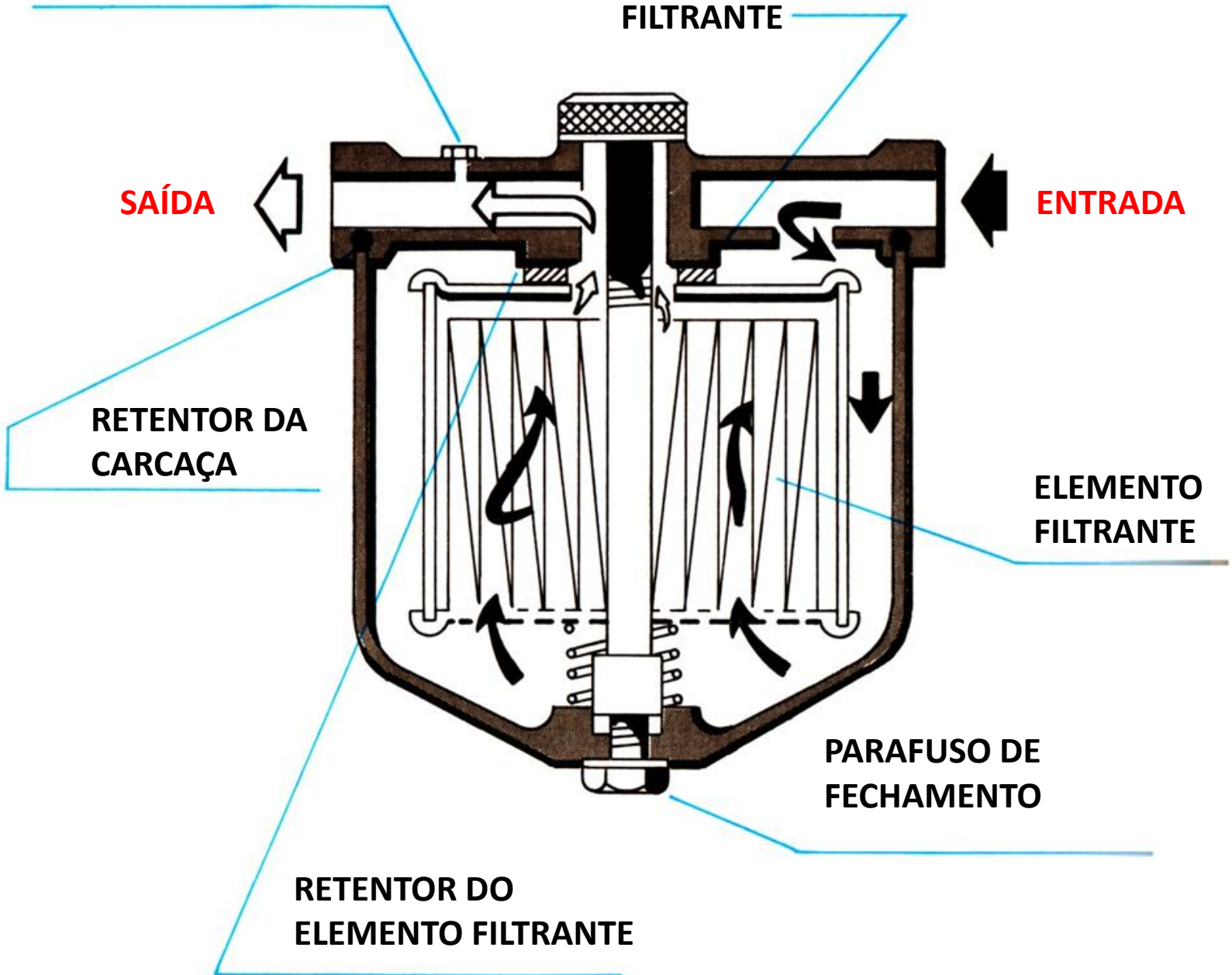

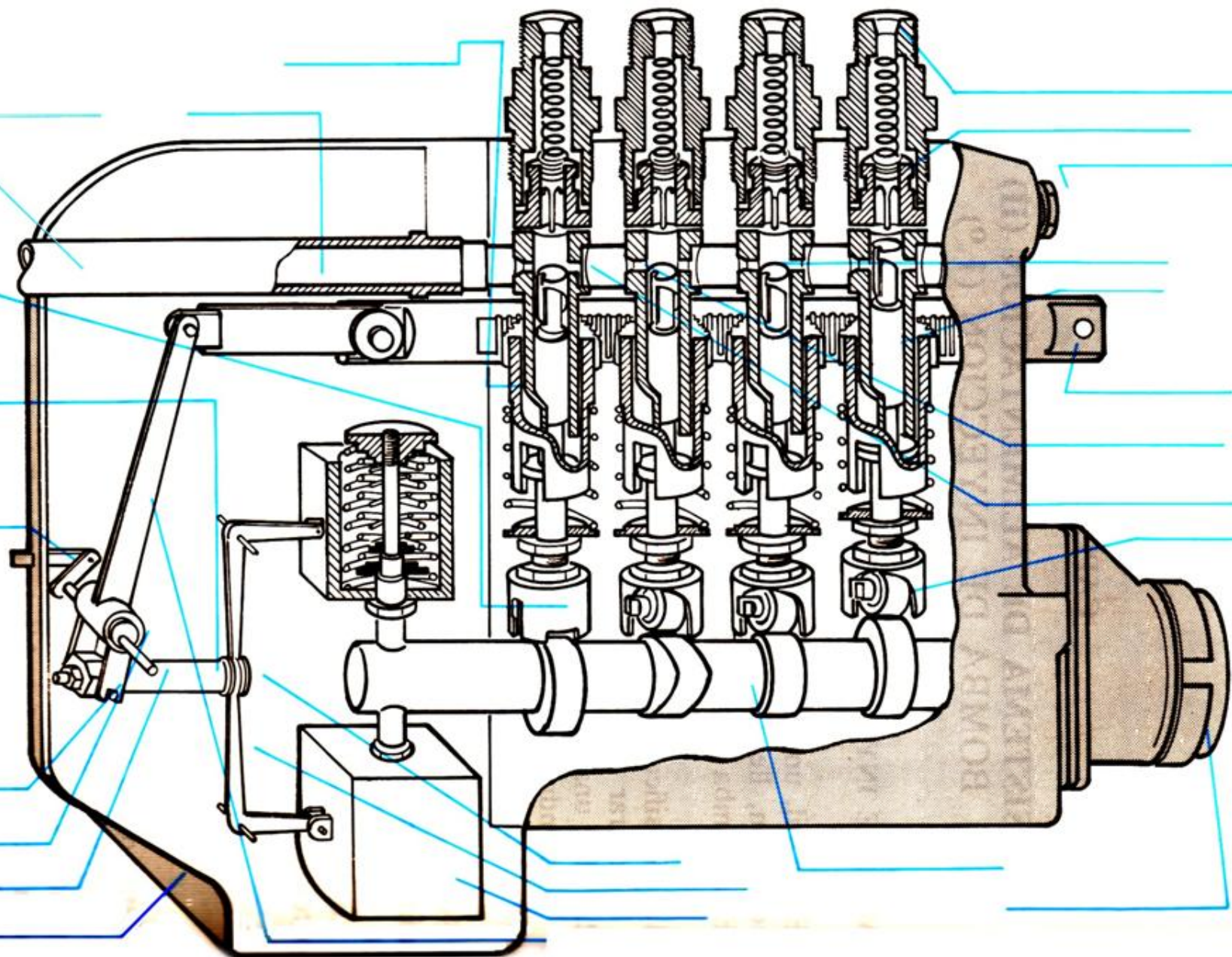

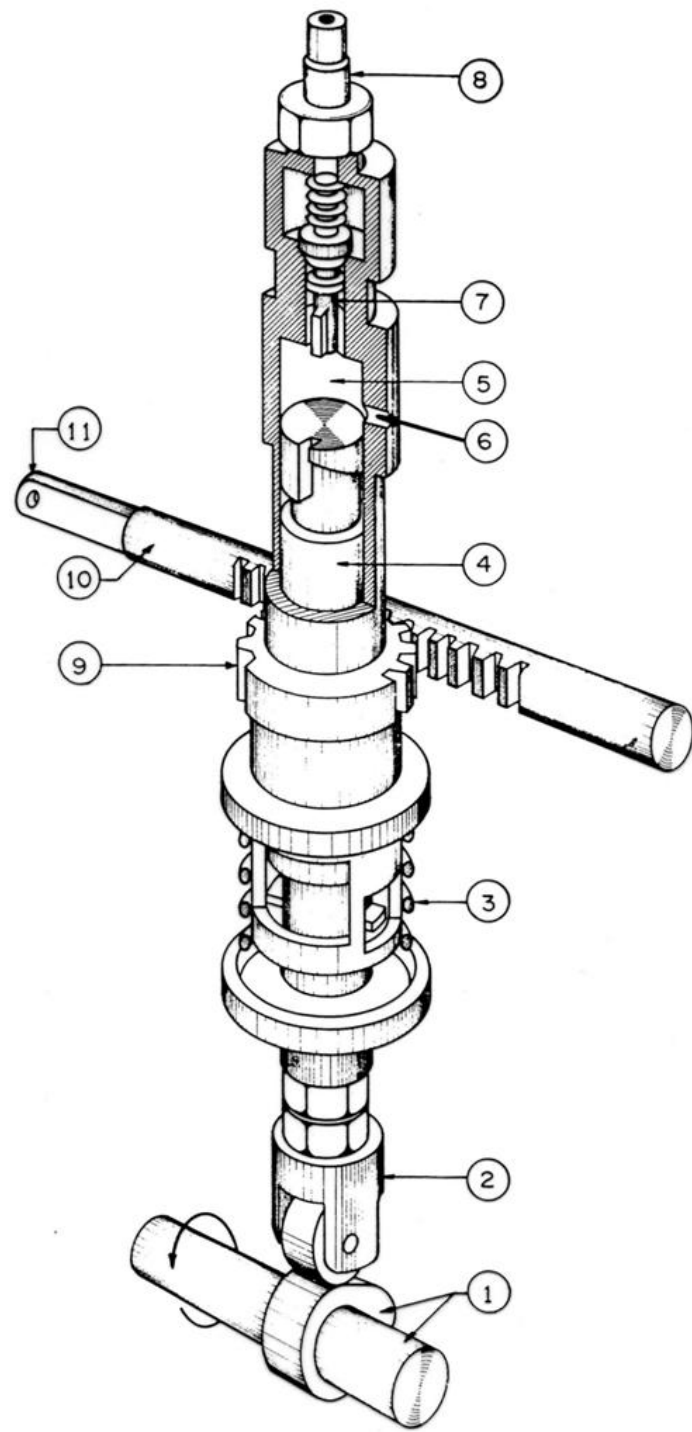

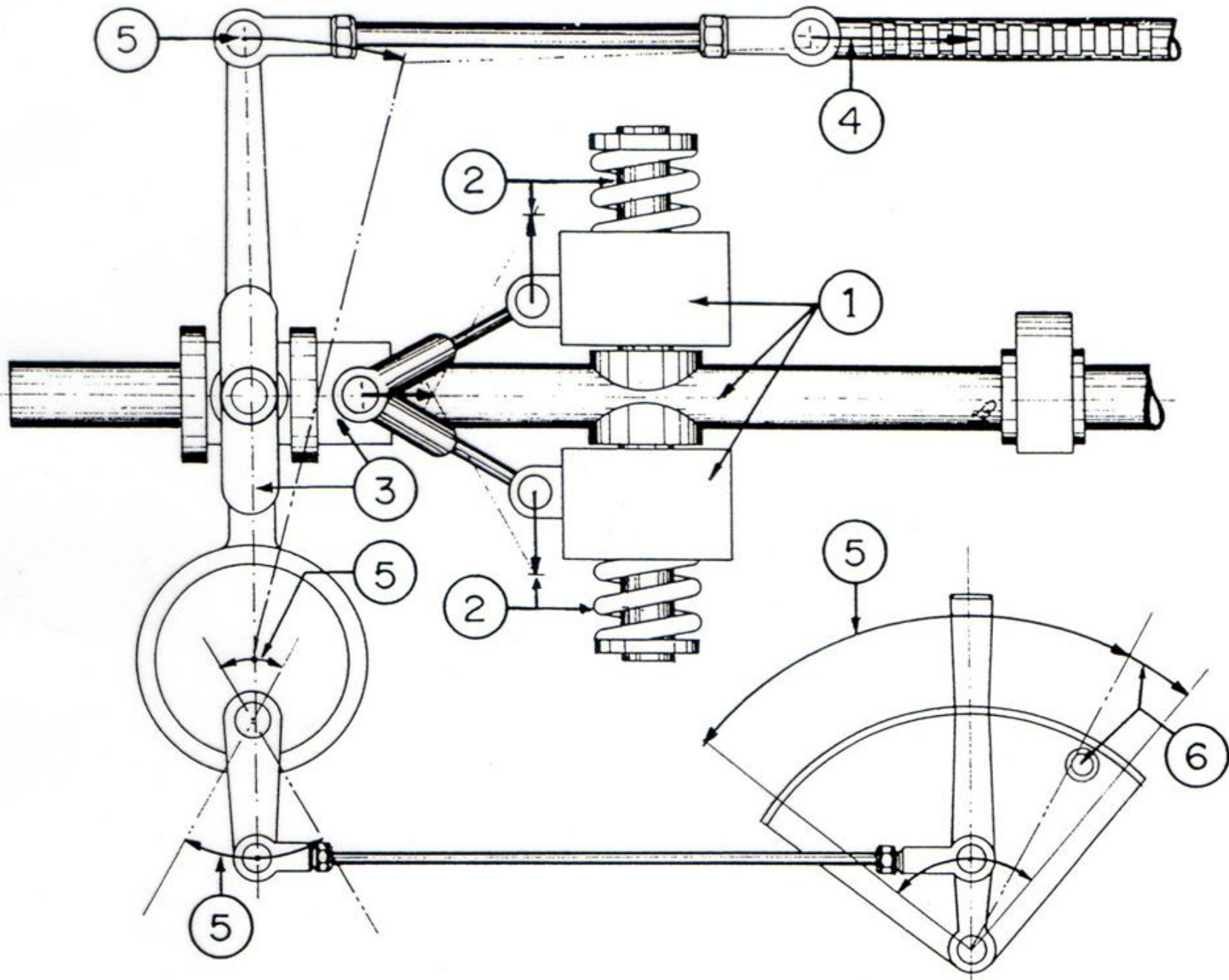

A quantidade de combustível injetada sendo função da posição da alavanca do acelerador manual

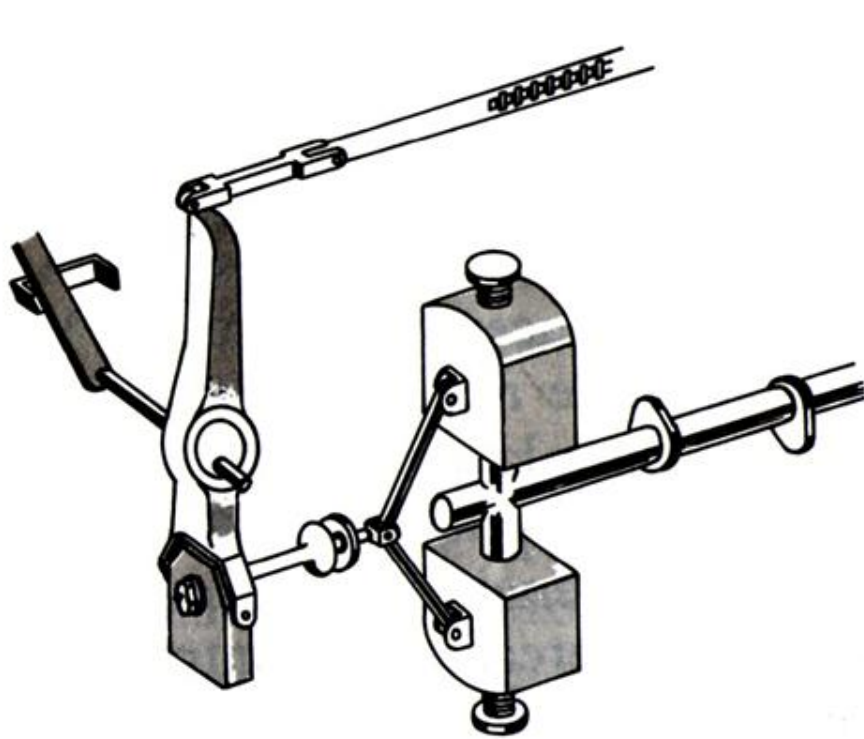

MENOR

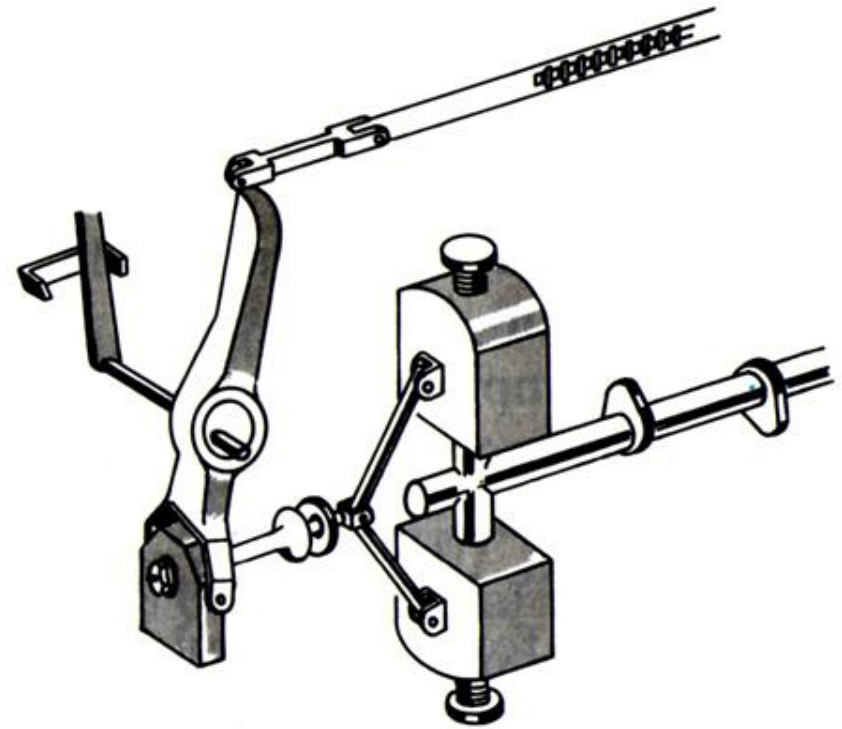

MAIOR

**A quantidade de combustível injetada sendo
função da carga aplicada**

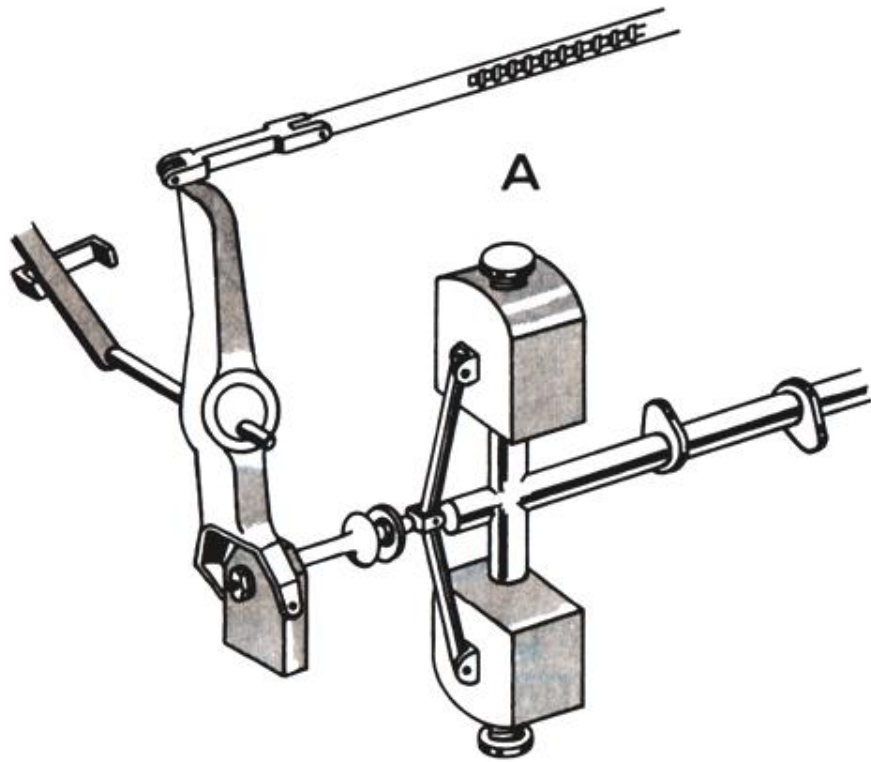

MENOR

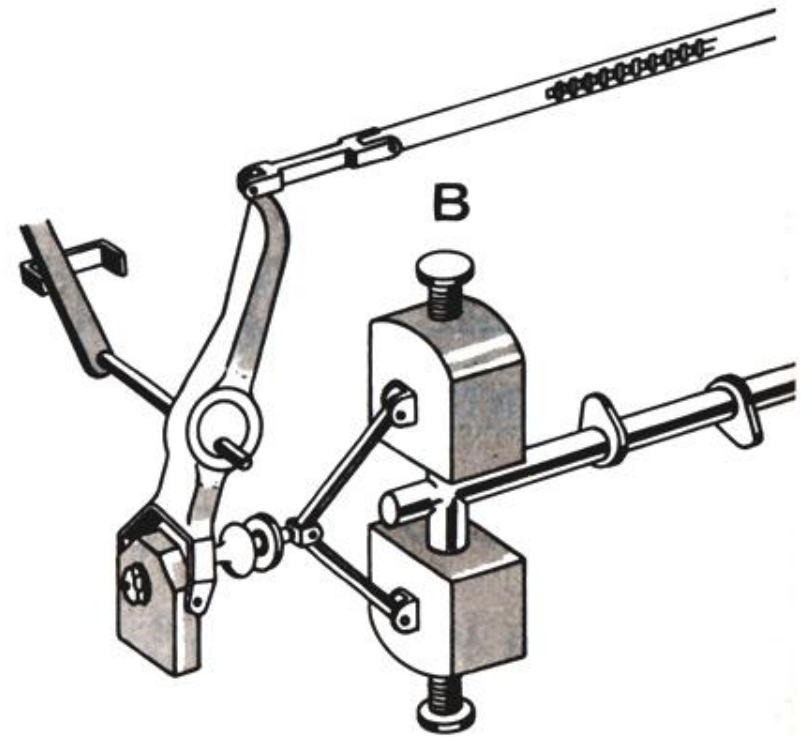

MAIOR

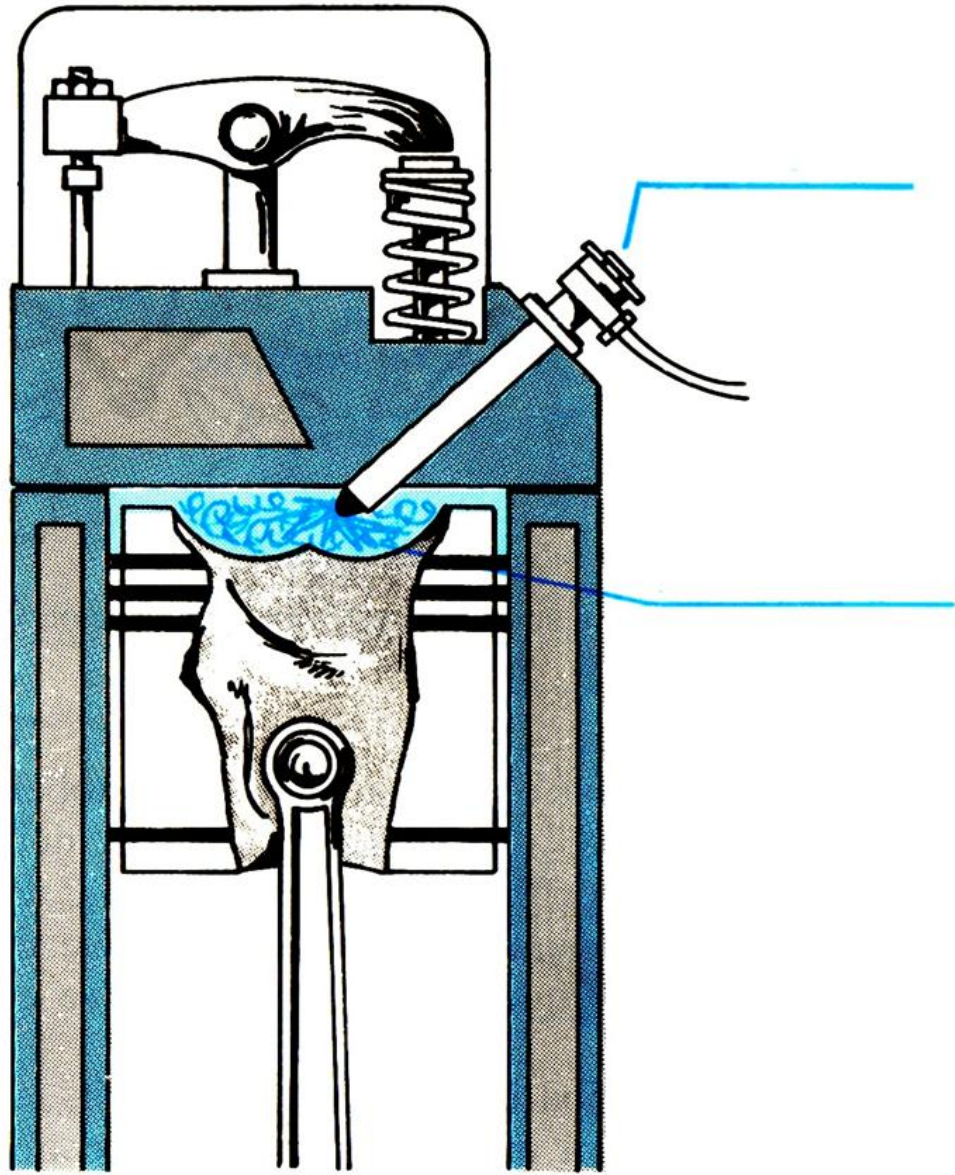

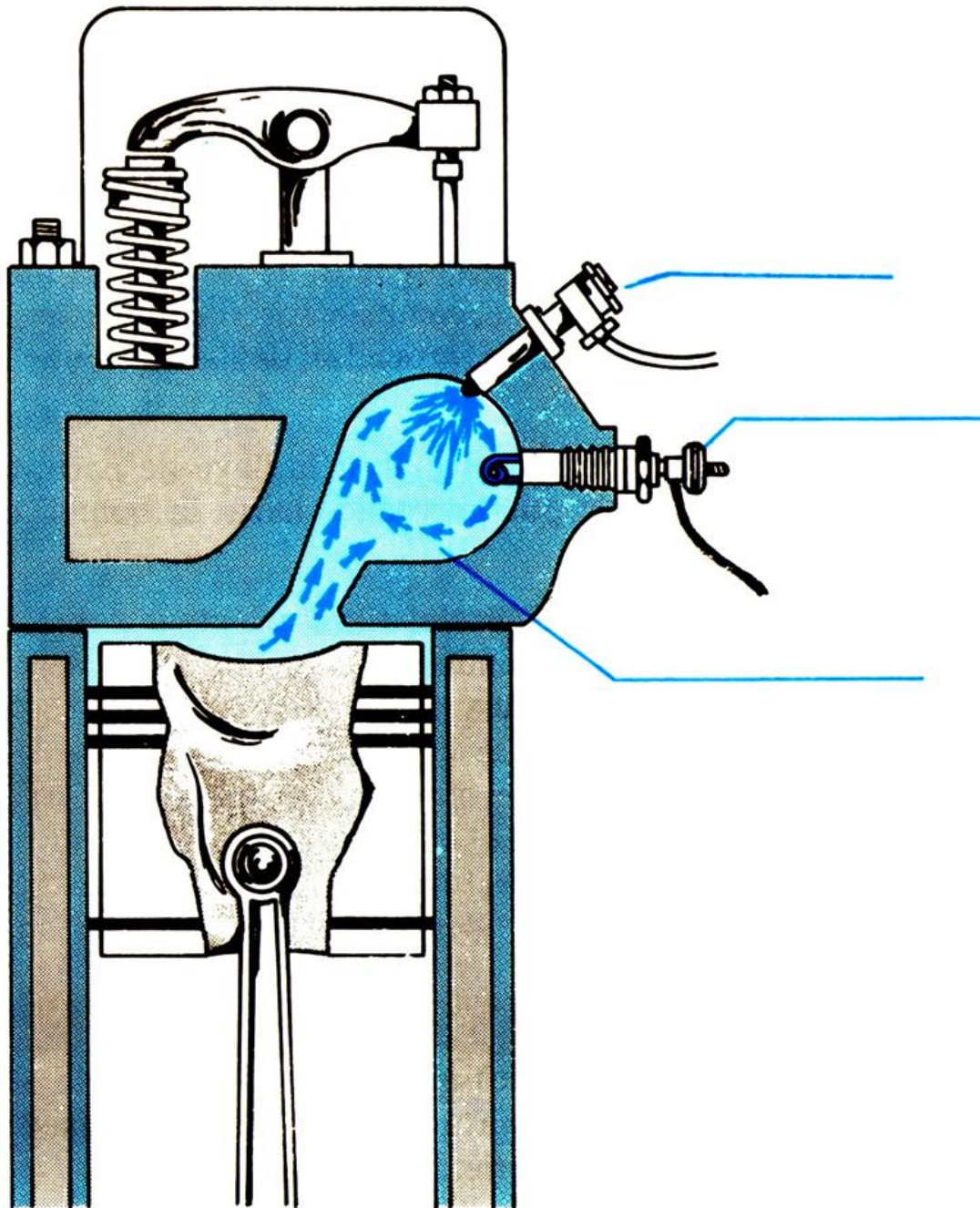



Sistema de Alimentação de ar dos Motores de Combustão Interna de Ciclo Diesel

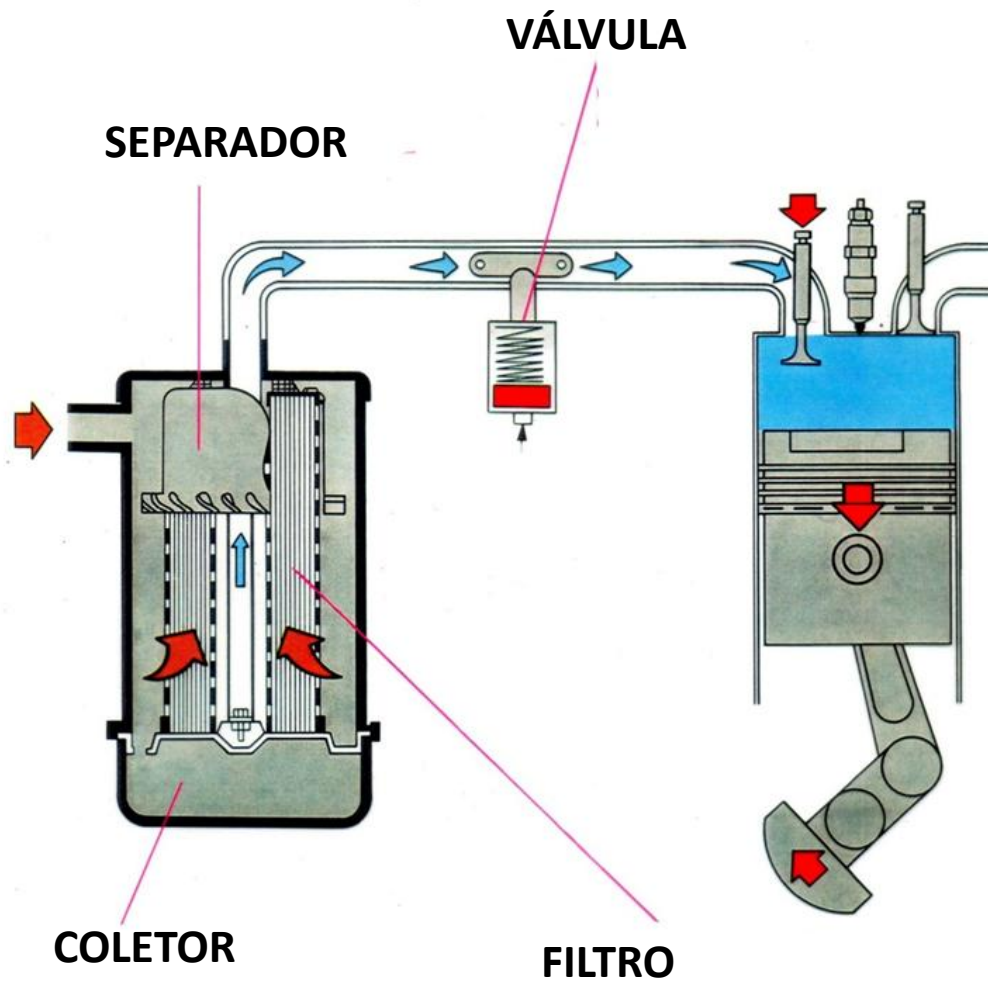

 → ar com impurezas
 → ar filtrado

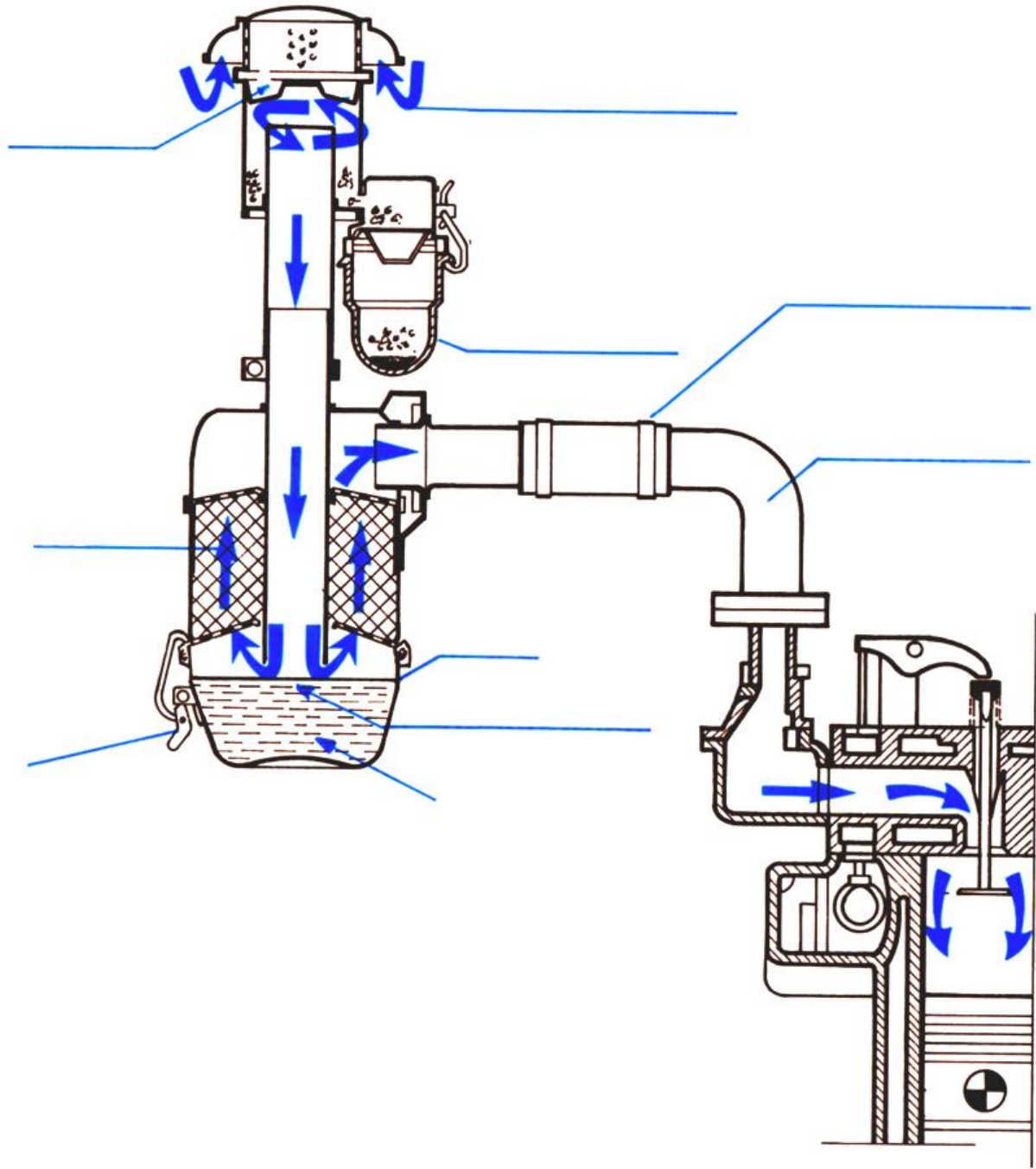

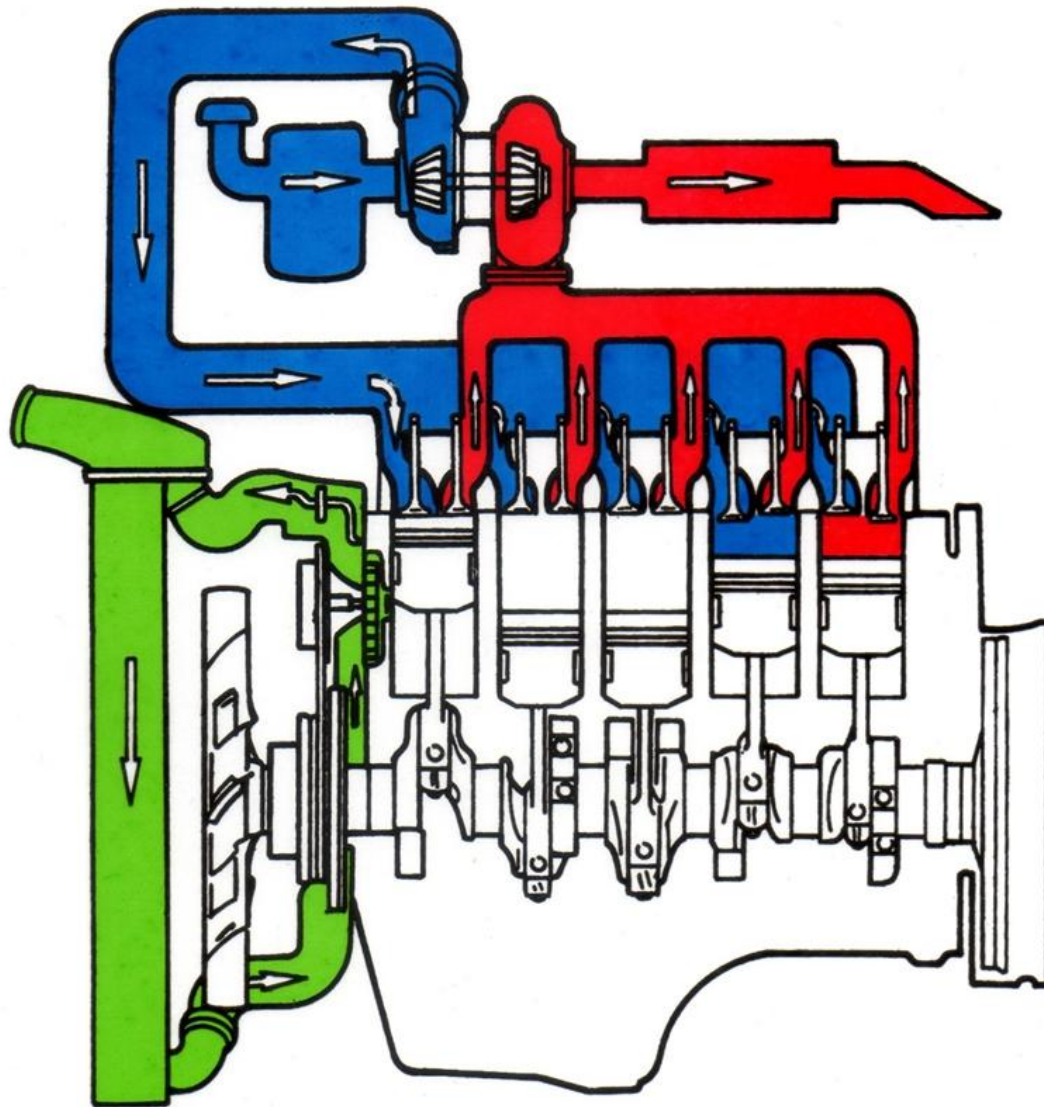

- Escape
- Admissão
- Arrefecimento

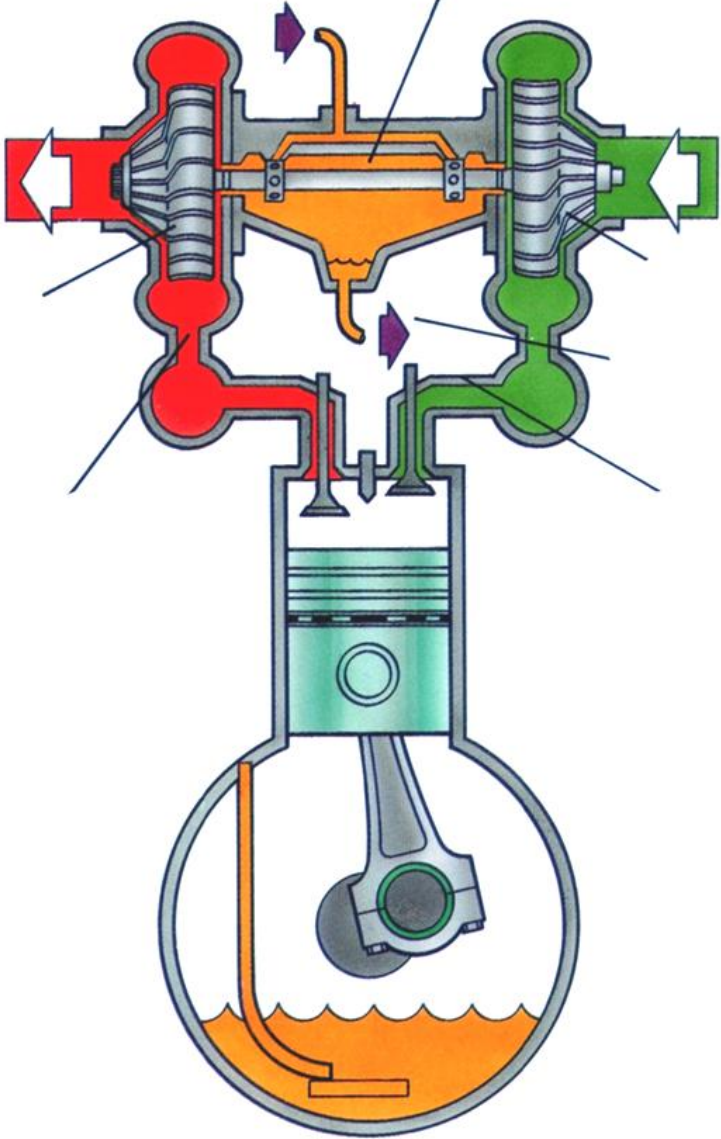

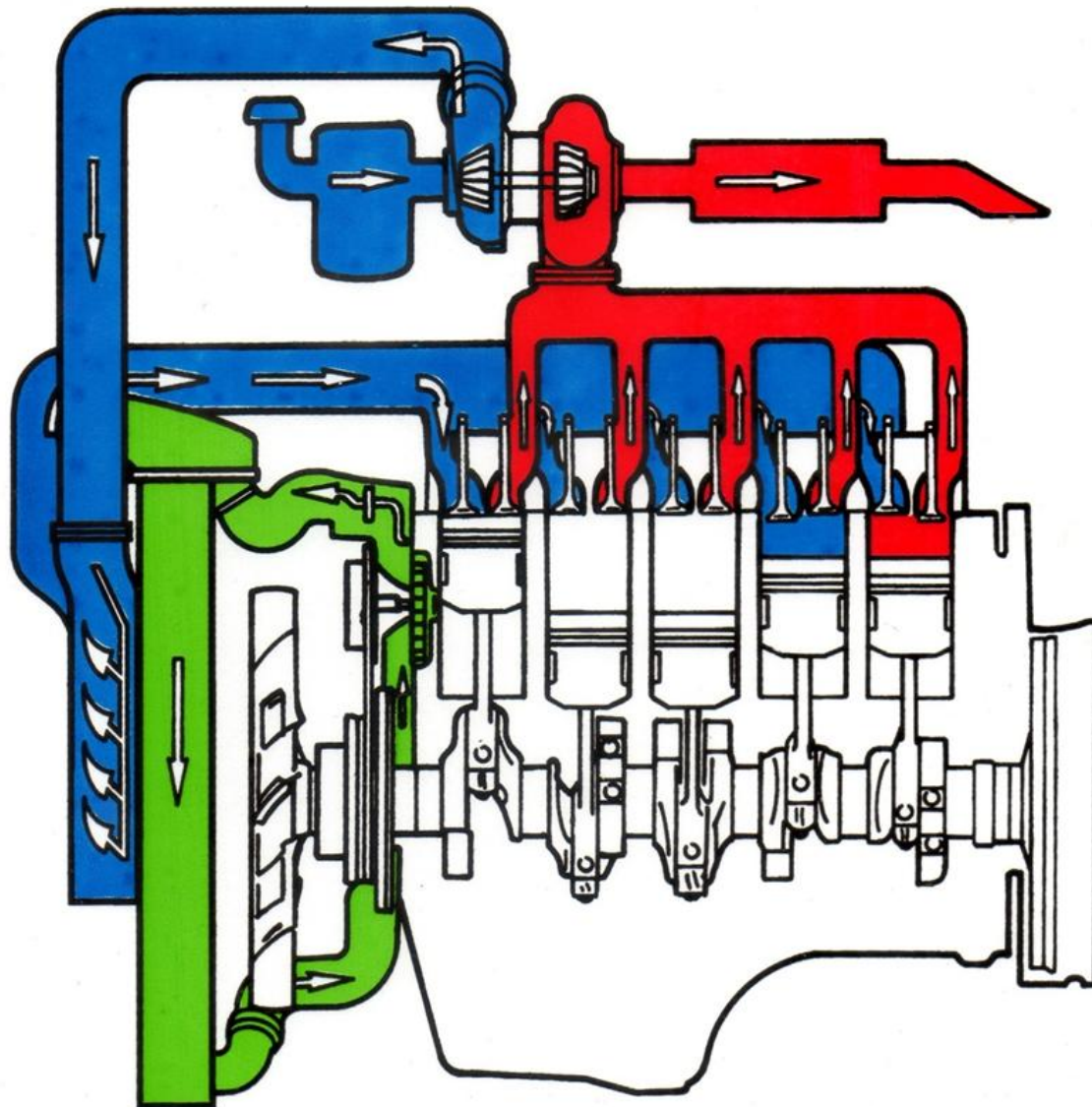

- Escape**
- Admissão**
- Arrefecimento**

VARIAÇÃO DO TORQUE, POTÊNCIA E CONSUMO ESPECÍFICO EM MOTORES COM ASPIRAÇÃO NATURAL, TURBO E TURBO INTERCOOLER

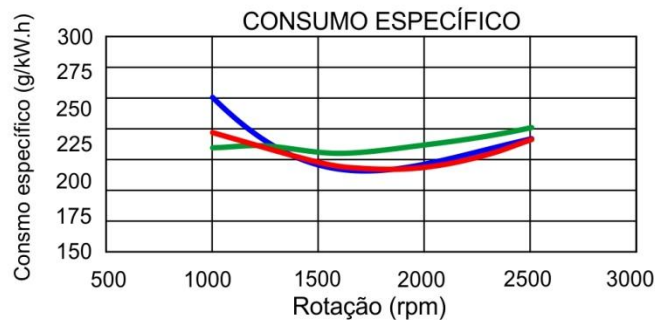
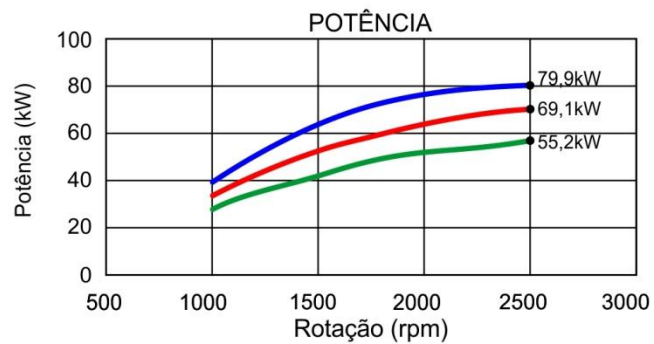
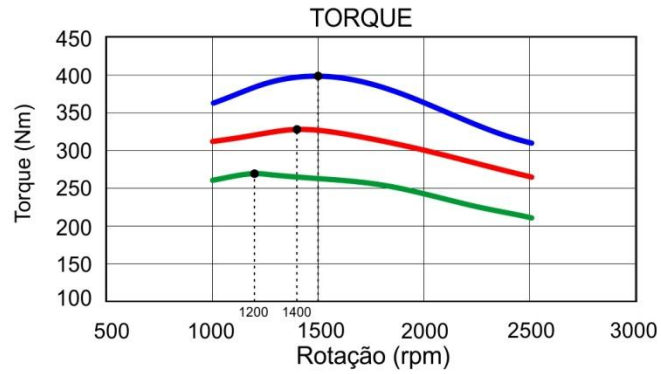

— TURBO-INTERCOOLER — TURBO — ASPIRAÇÃO NATURAL

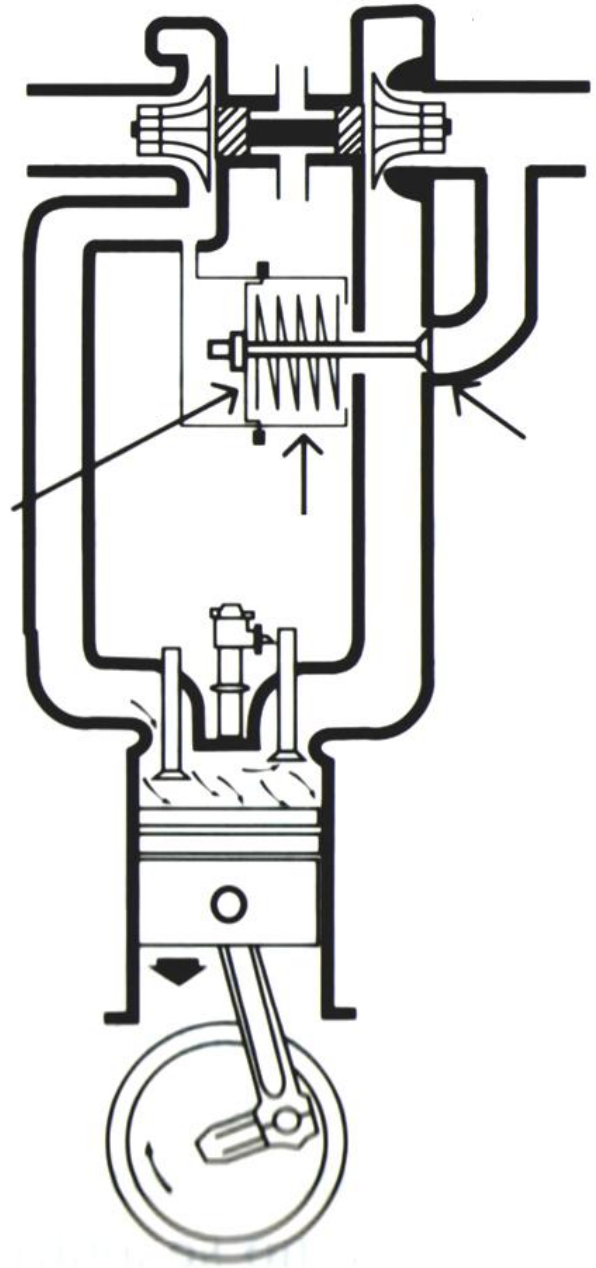

Sistema de Lubrificação dos Motores de Combustão Interna de Ciclo Diesel

Secção de uma superfície metálica ampliada

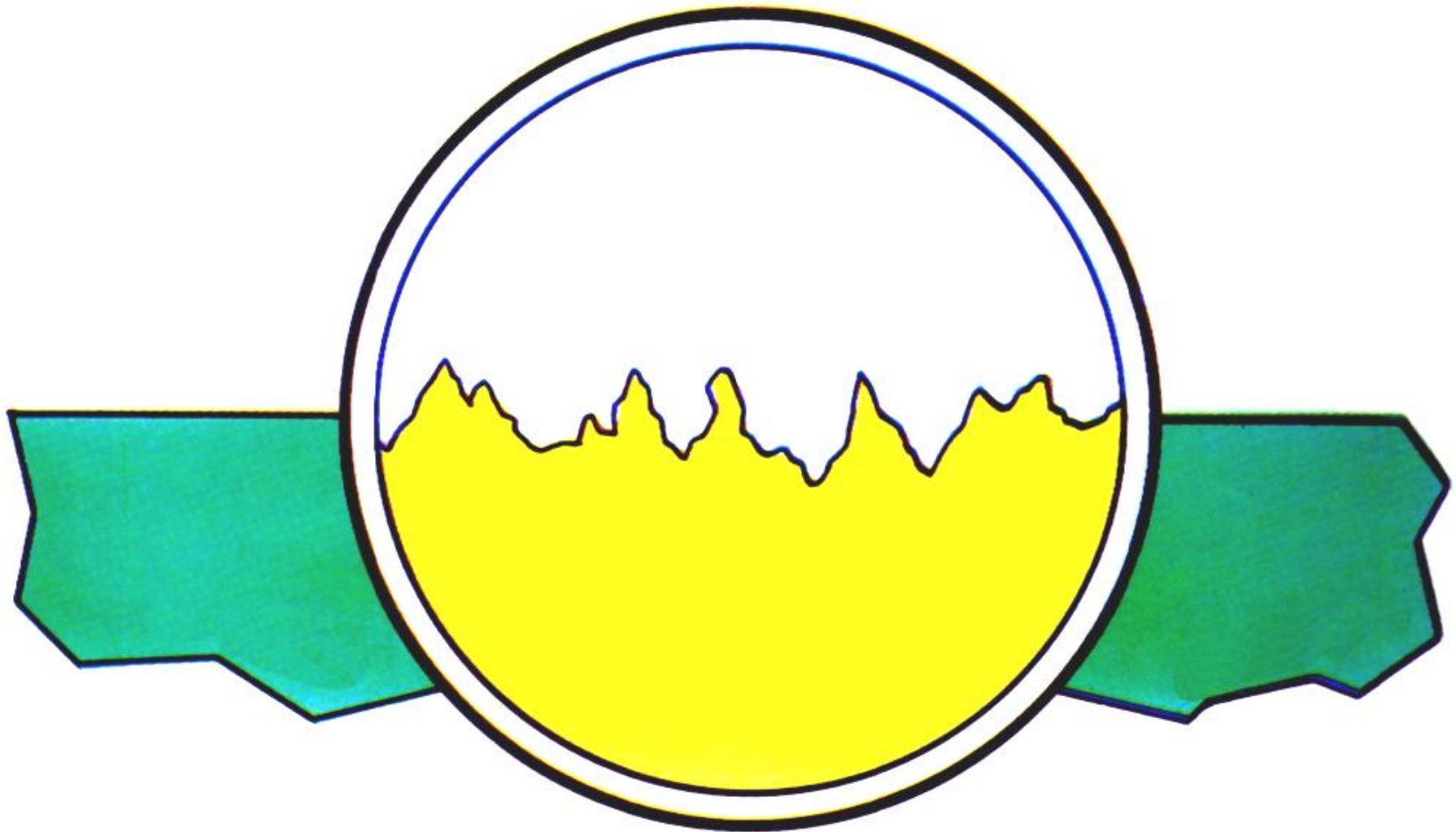

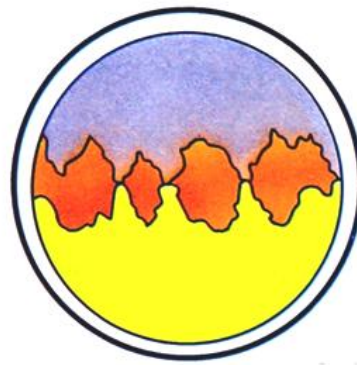

Contacto de duas superfícies metálicas

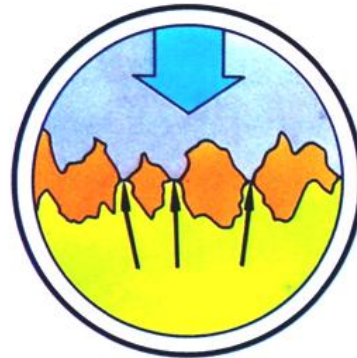

Pontos de contacto entre duas superfícies metálicas sob carga

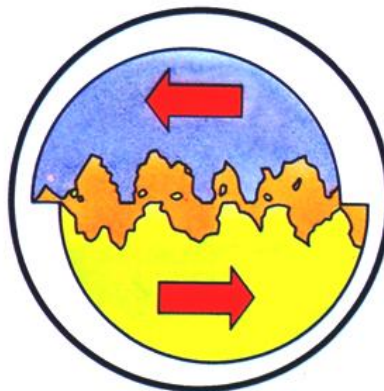

Movimento relativo entre duas superfícies metálicas

Lubrificante

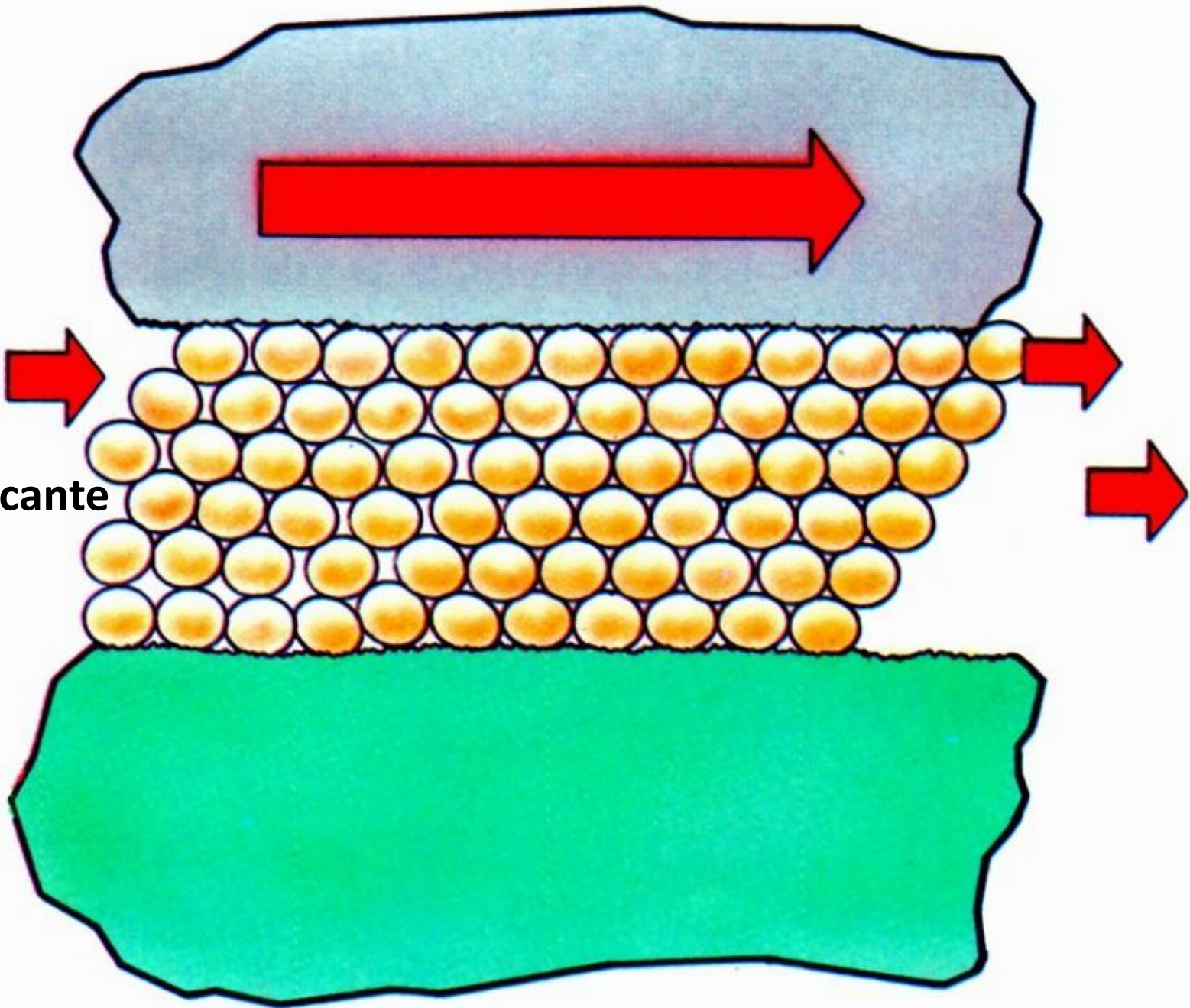

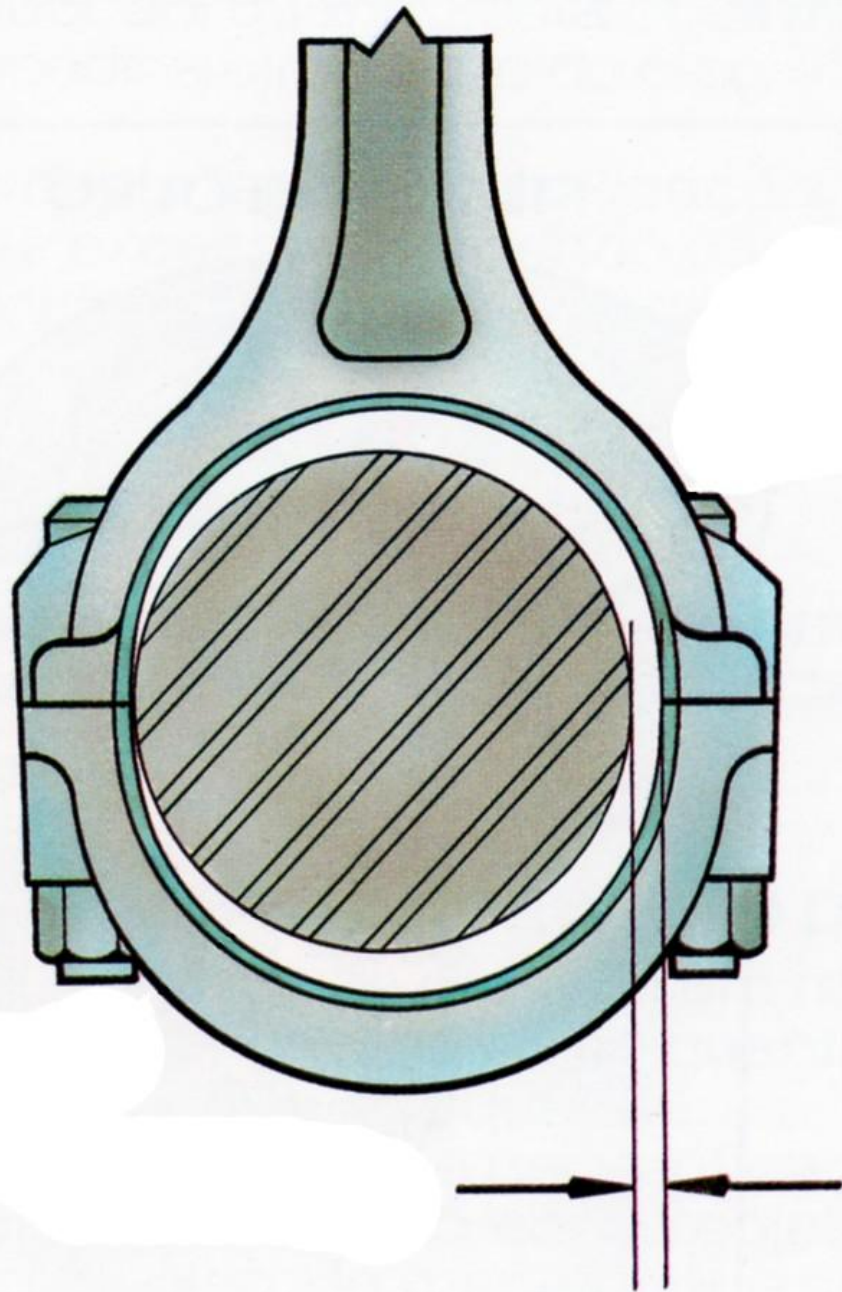

Funções do sistema de lubrificação

- REDUÇÃO DO ATRITO**
- REDUÇÃO DO DESGASTE**
- DIMINUIÇÃO DO RUÍDO**
- AÇÃO ARREFECEDORA**
- ELIMINAÇÃO DE IMPUREZAS**

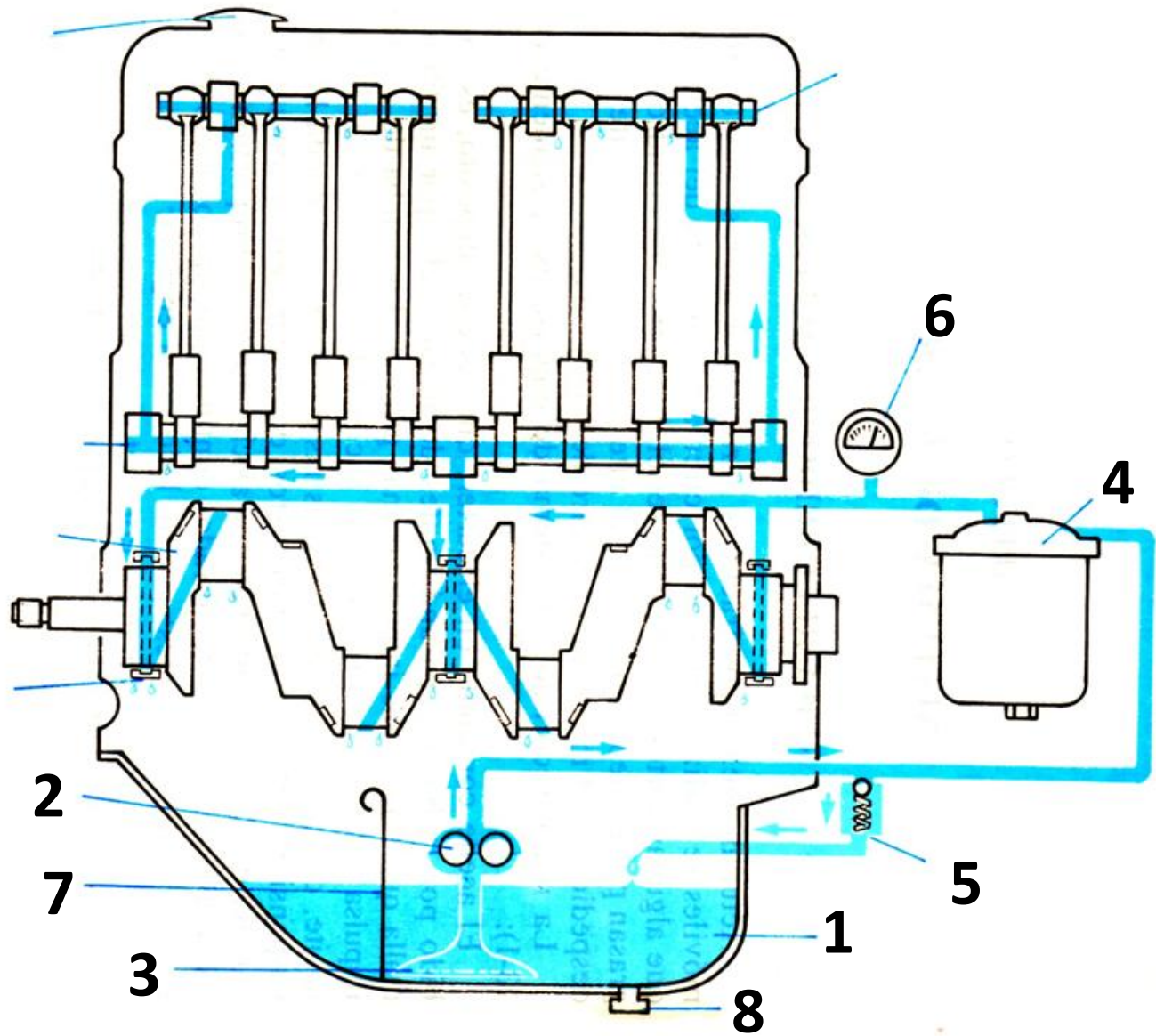

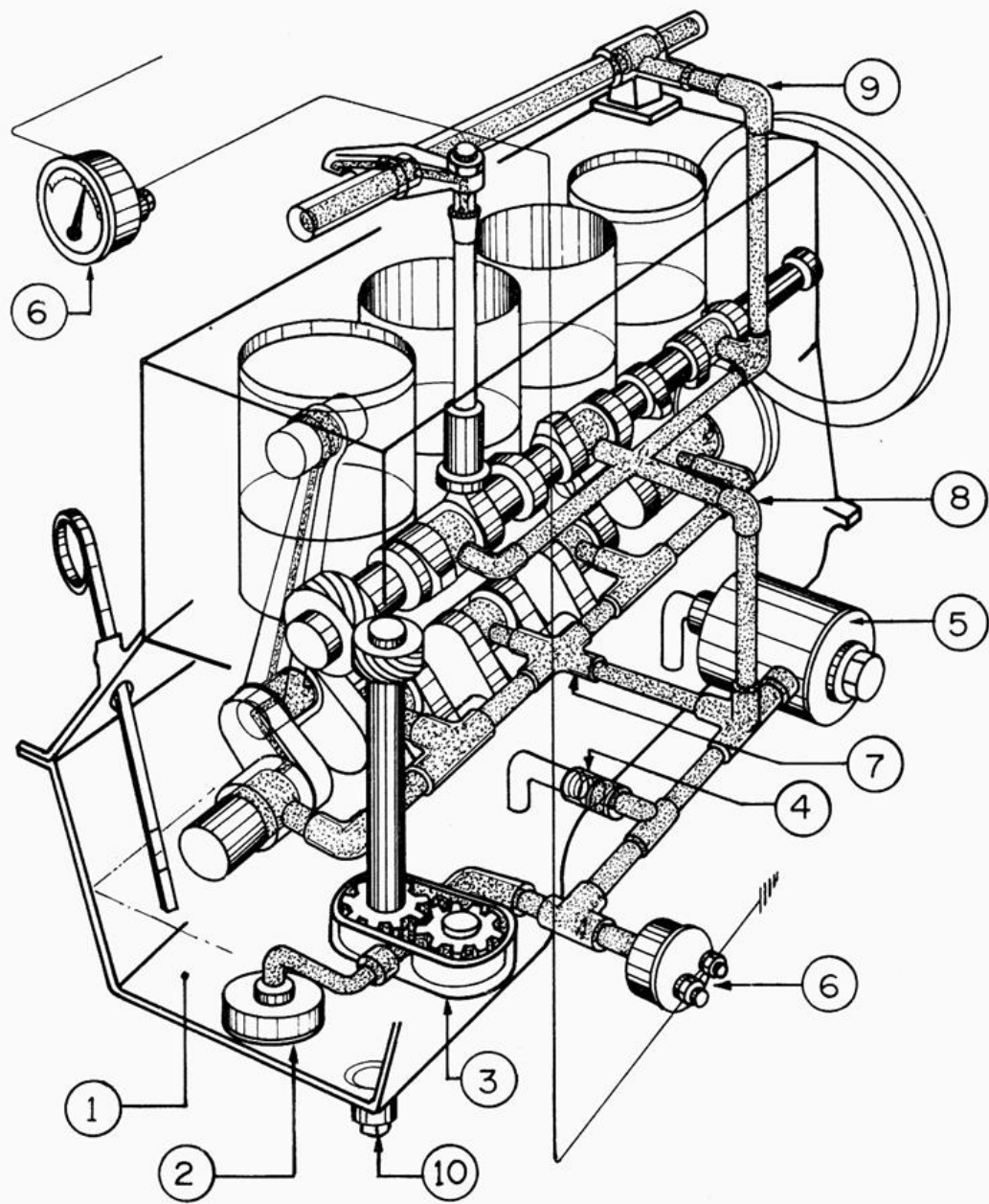

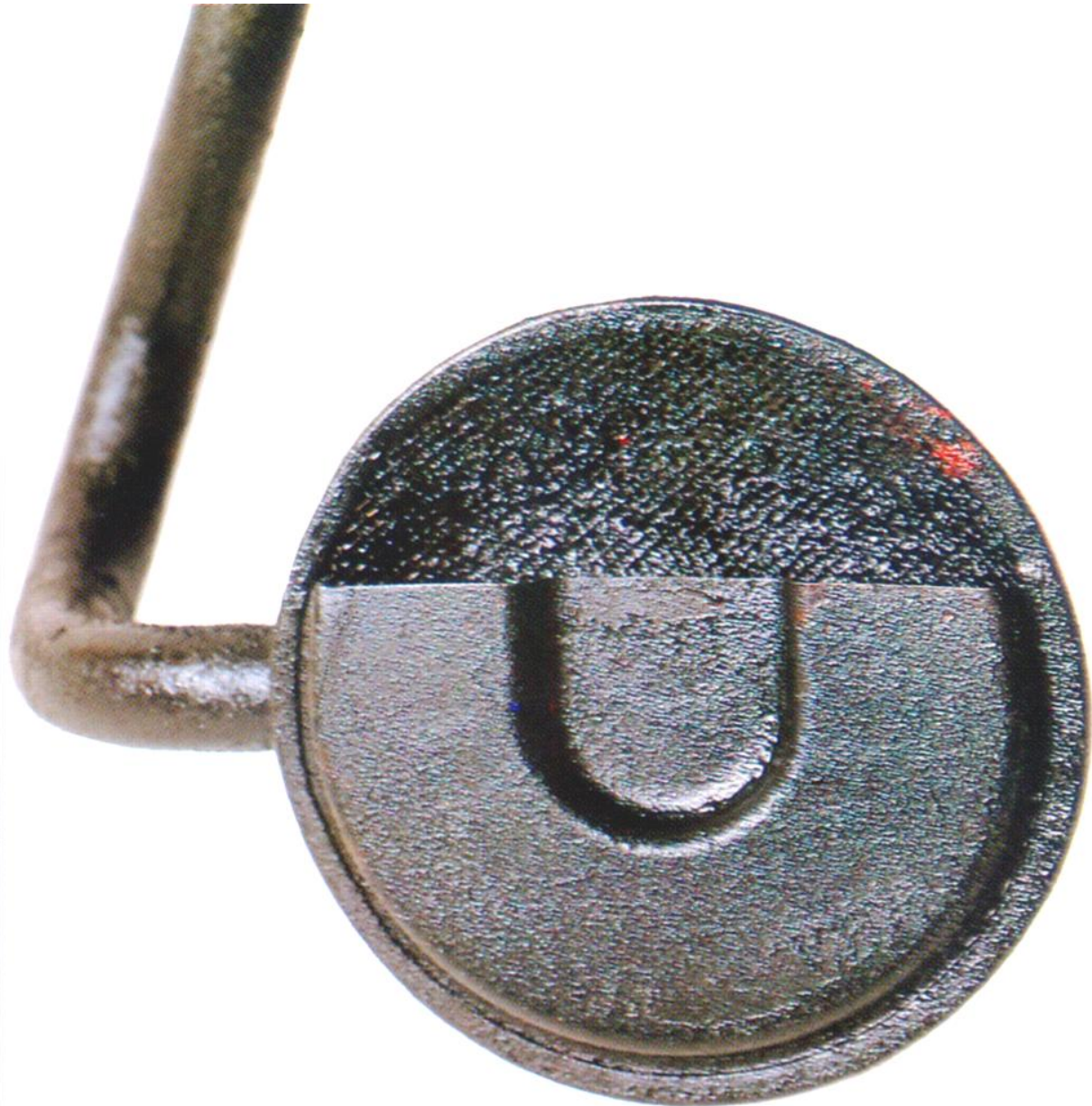

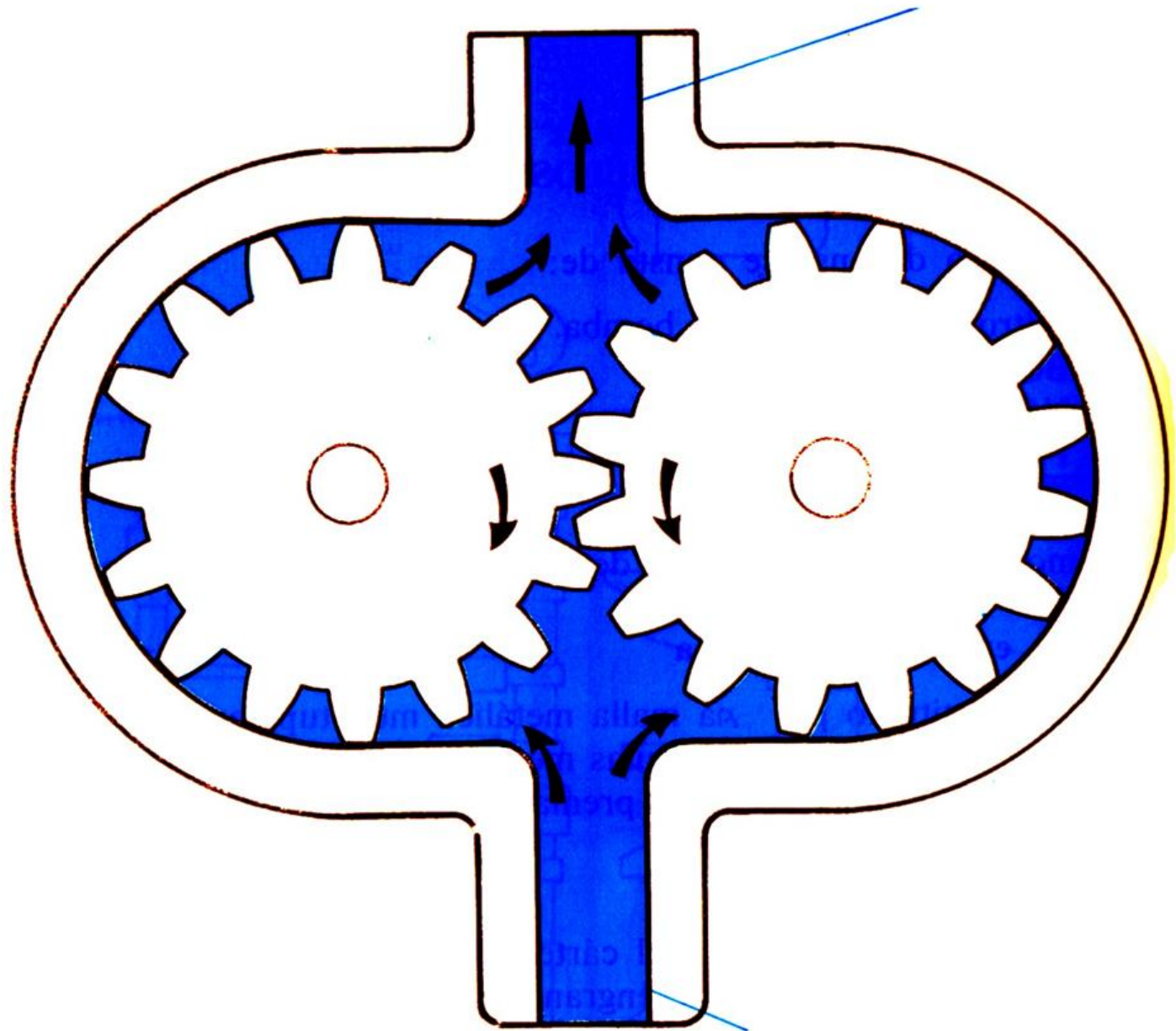

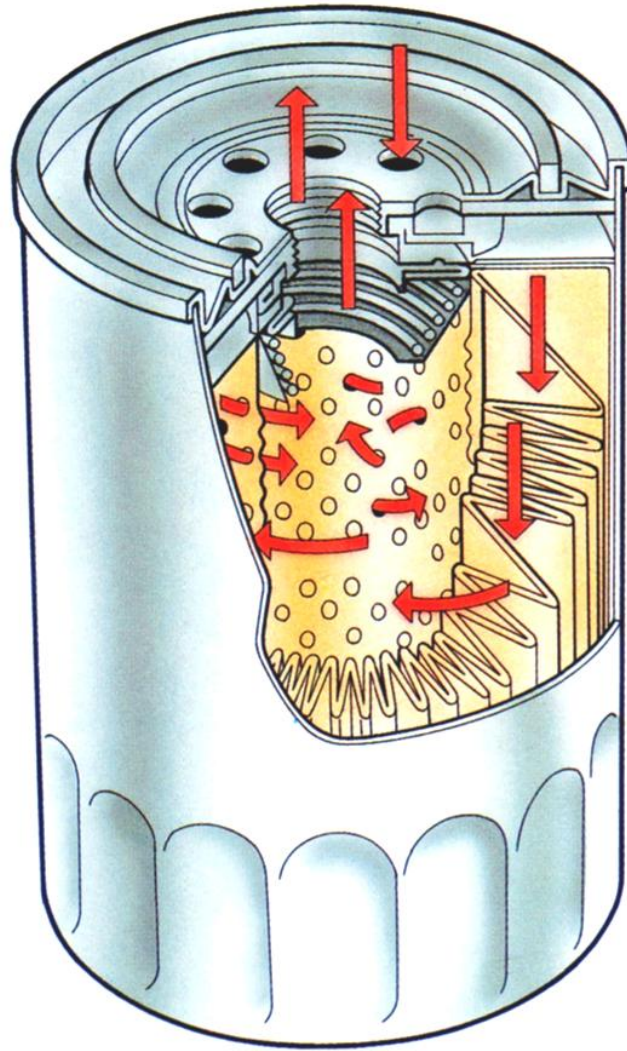

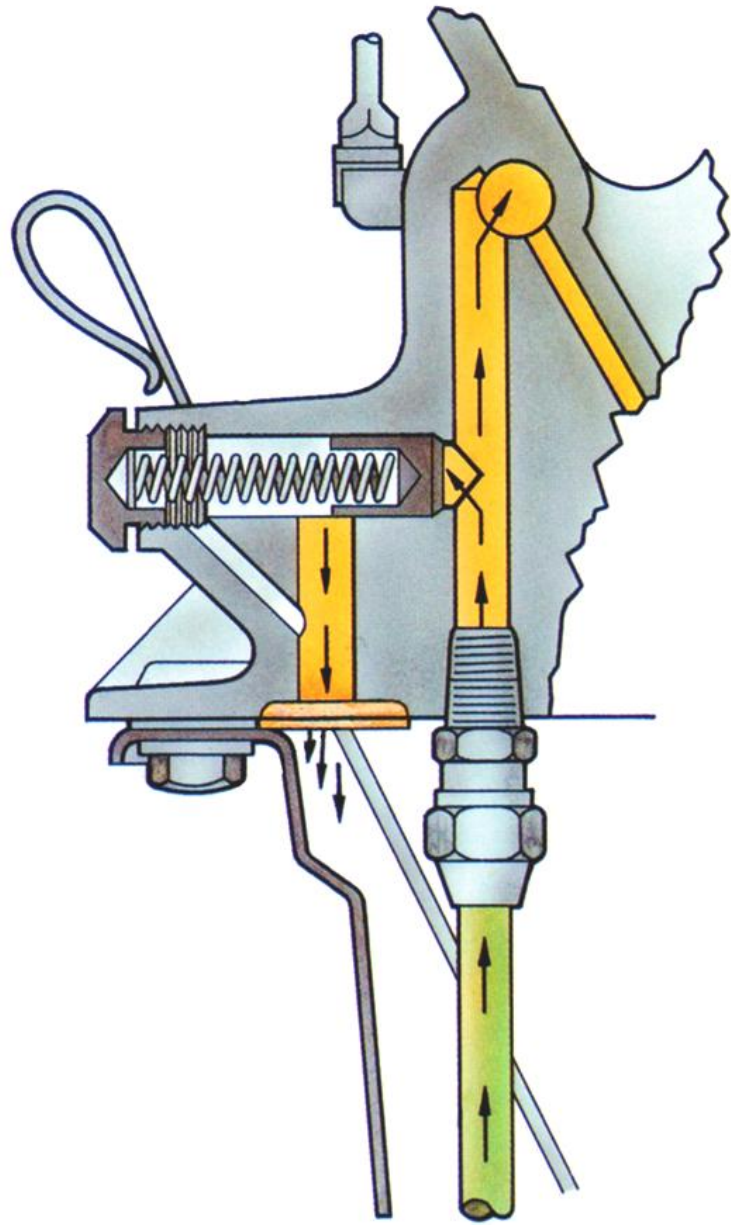

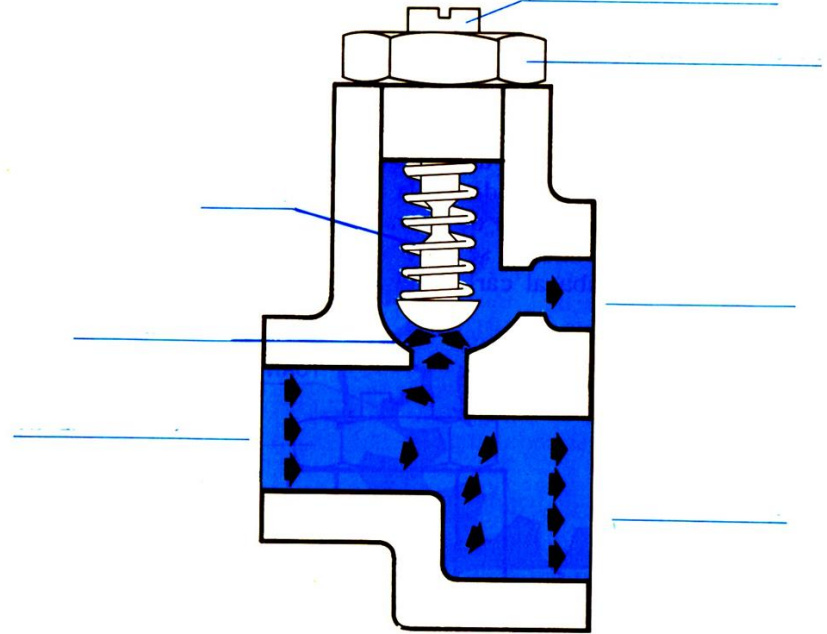
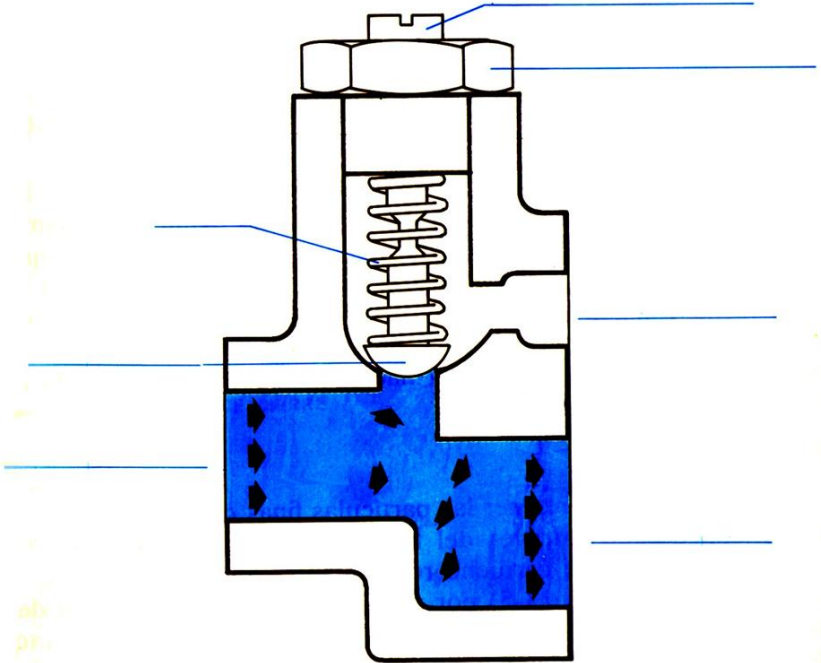

Sistema de Arrefecimento dos Motores de Combustão Interna do Ciclo Diesel

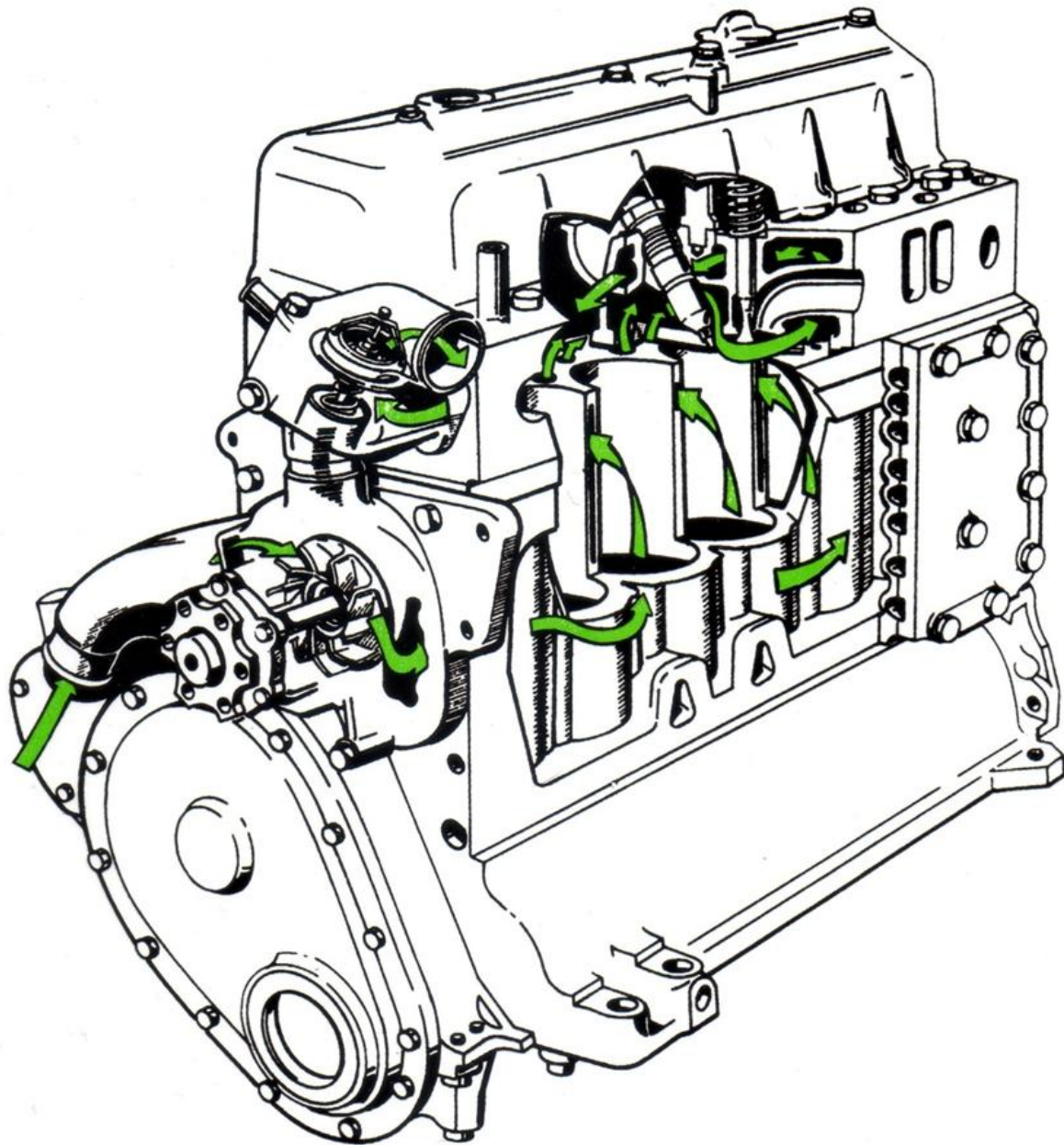

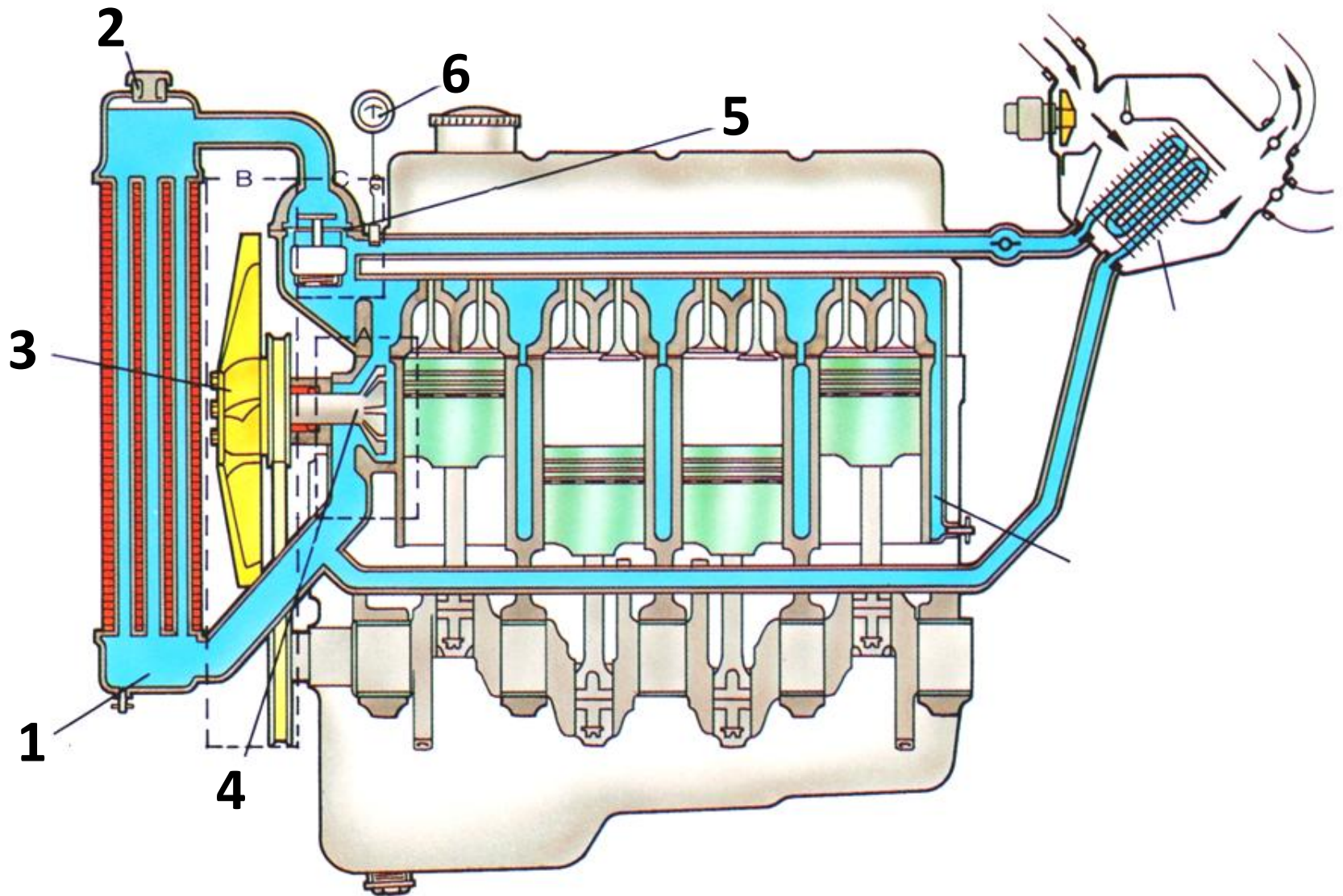

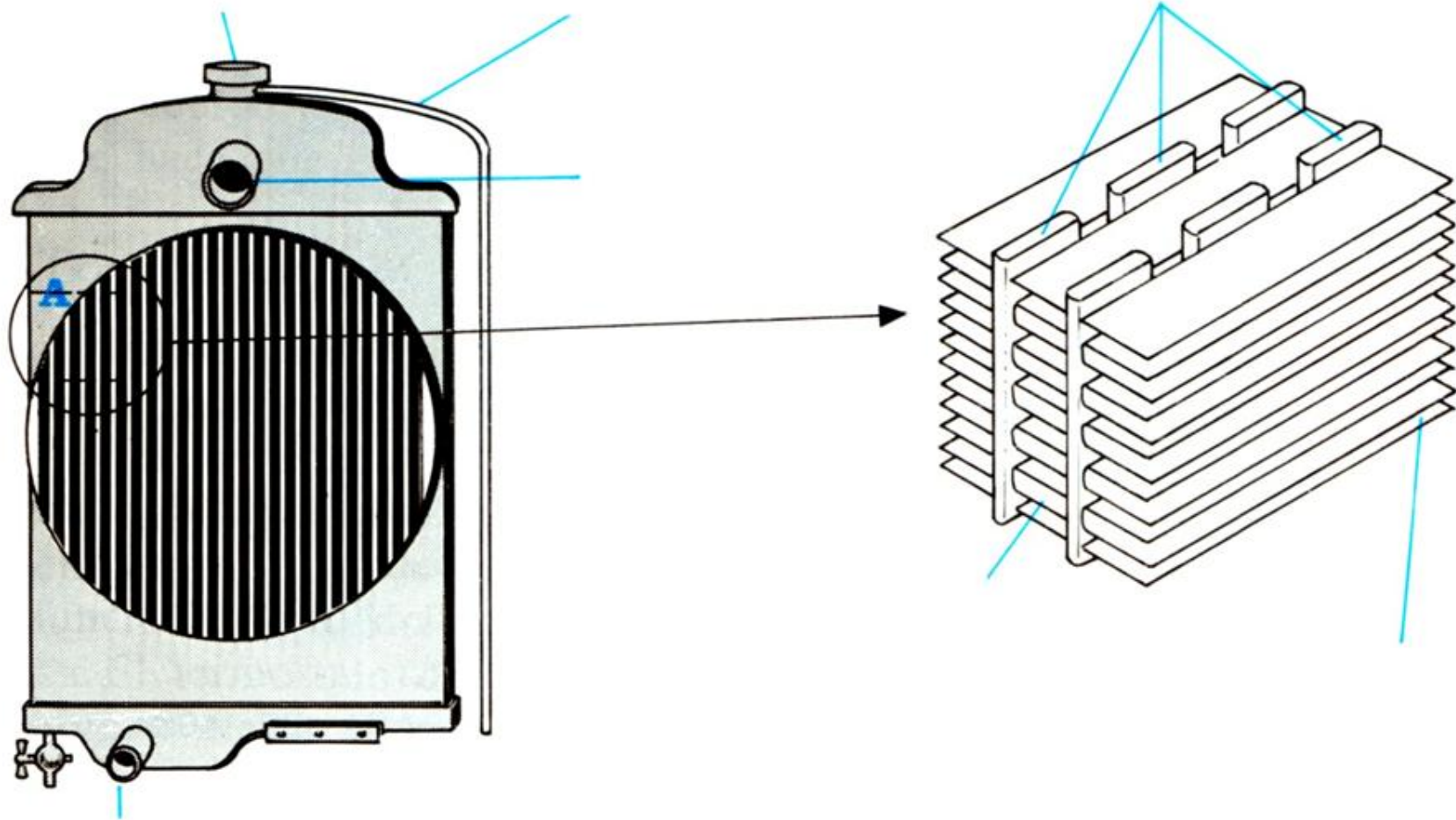

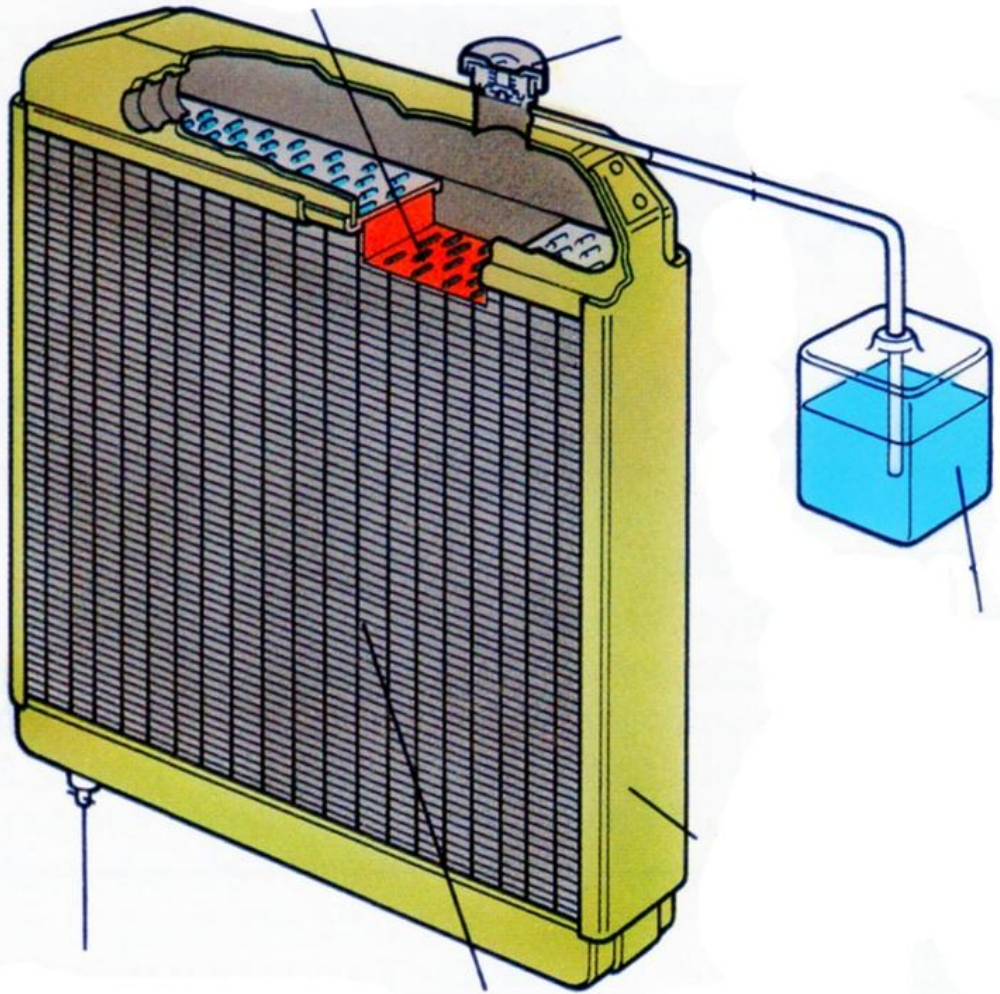

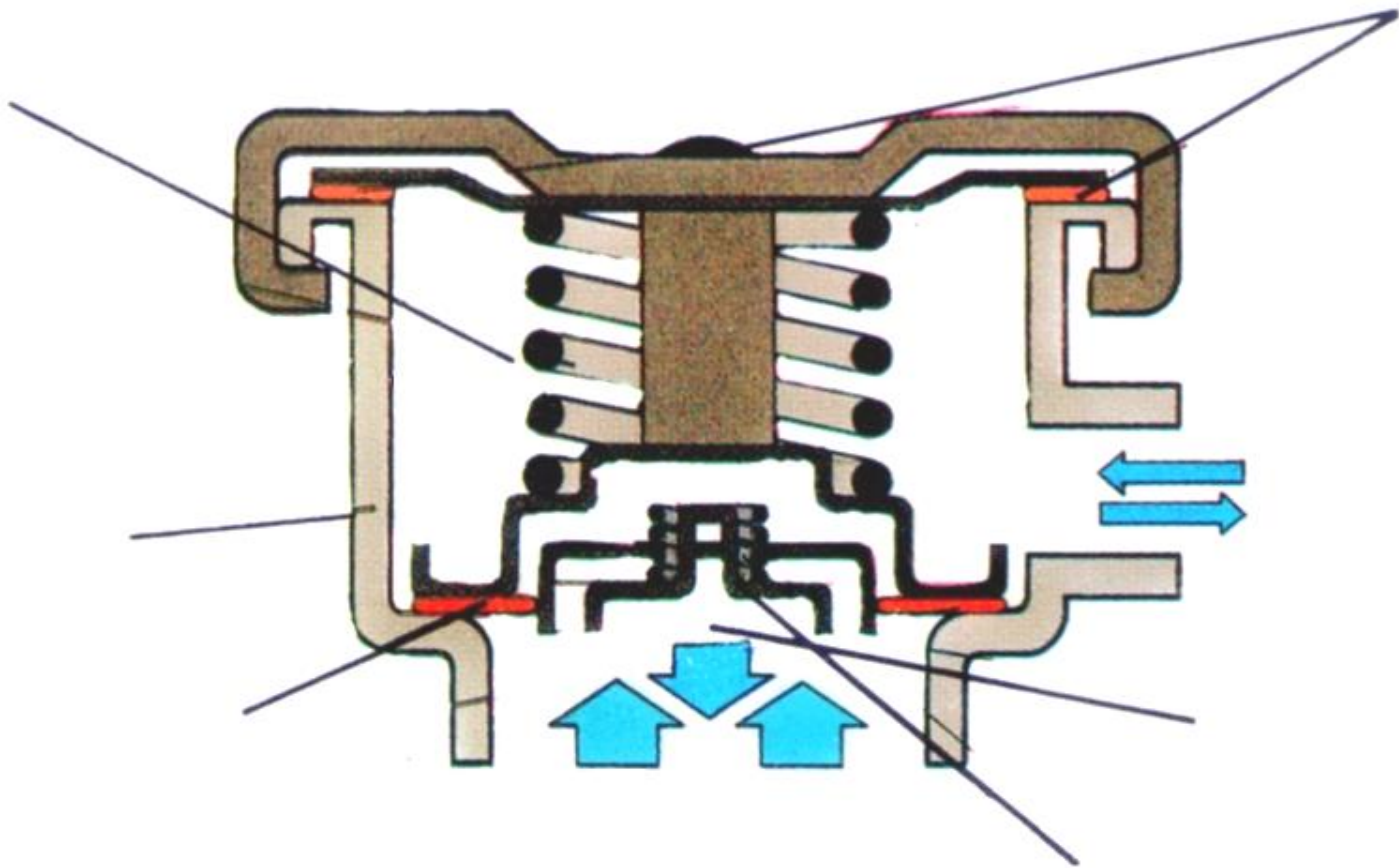

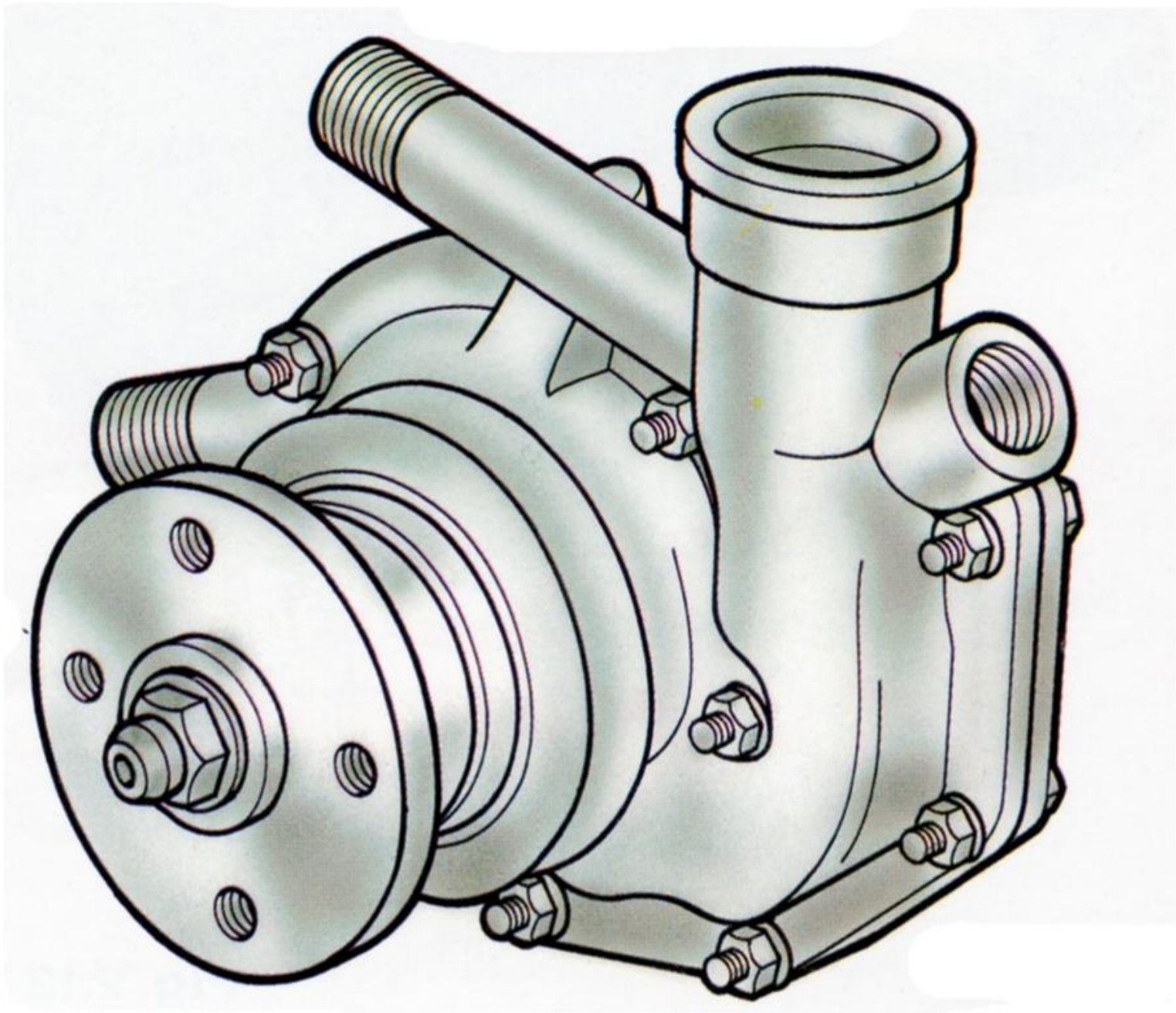

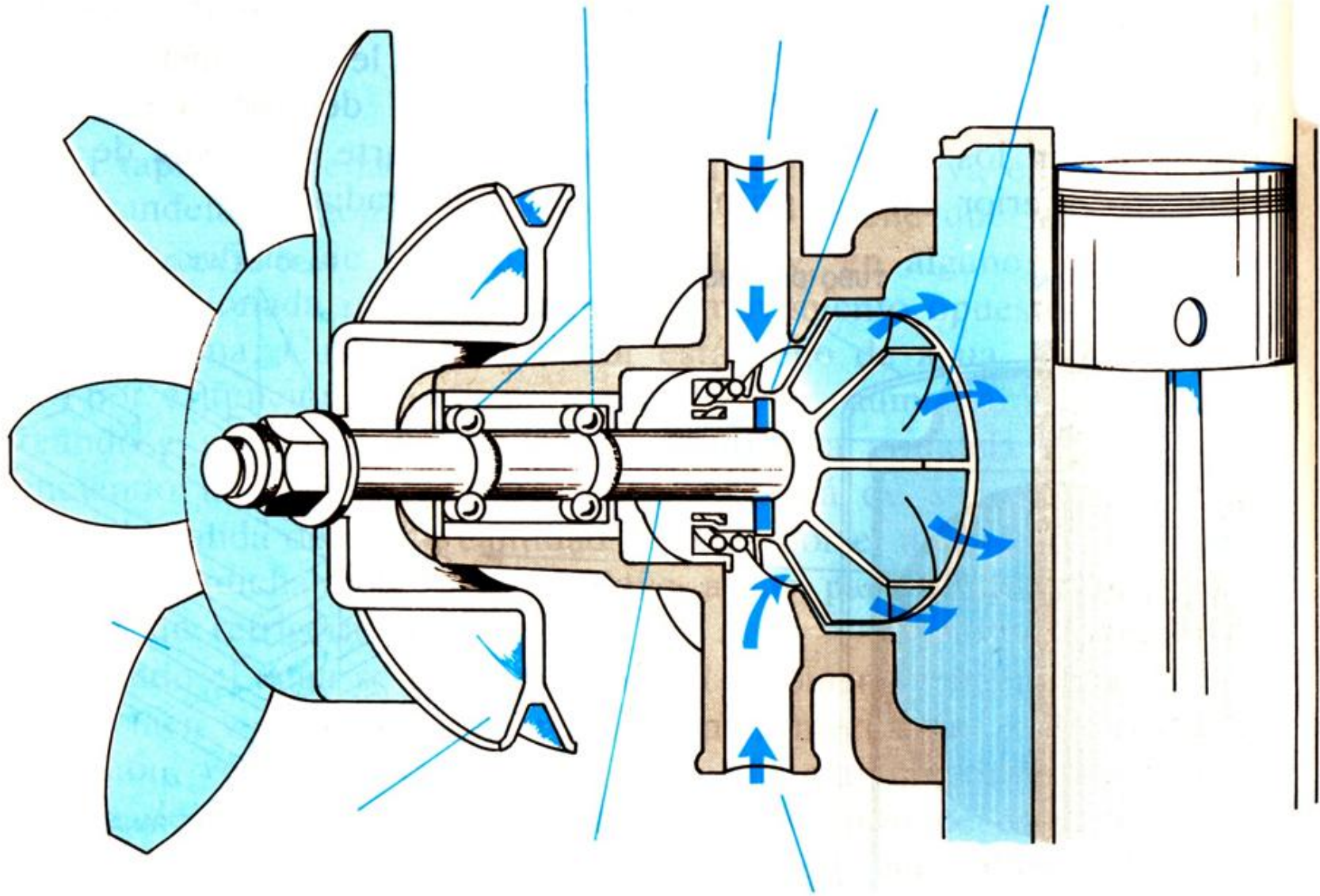

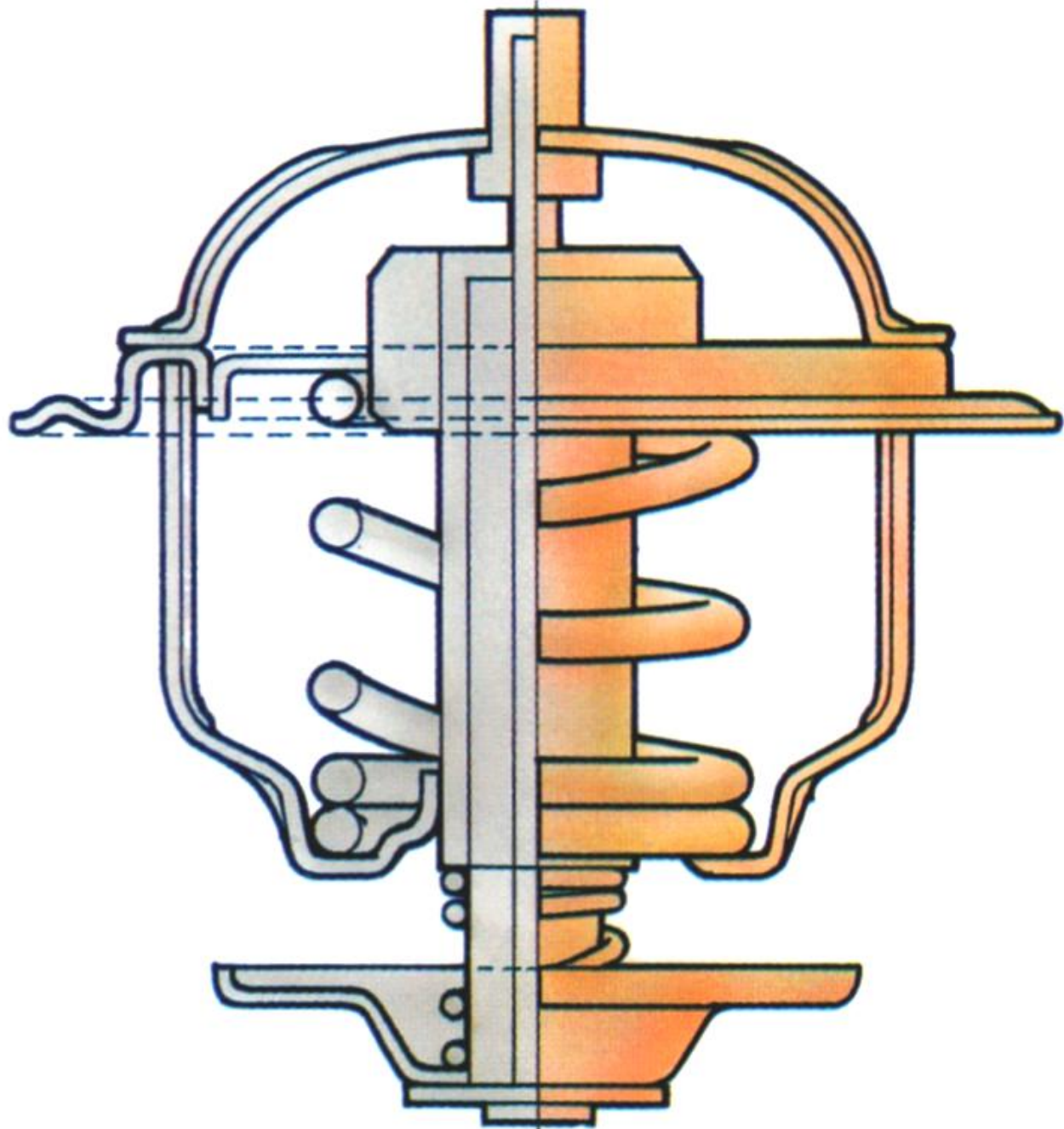

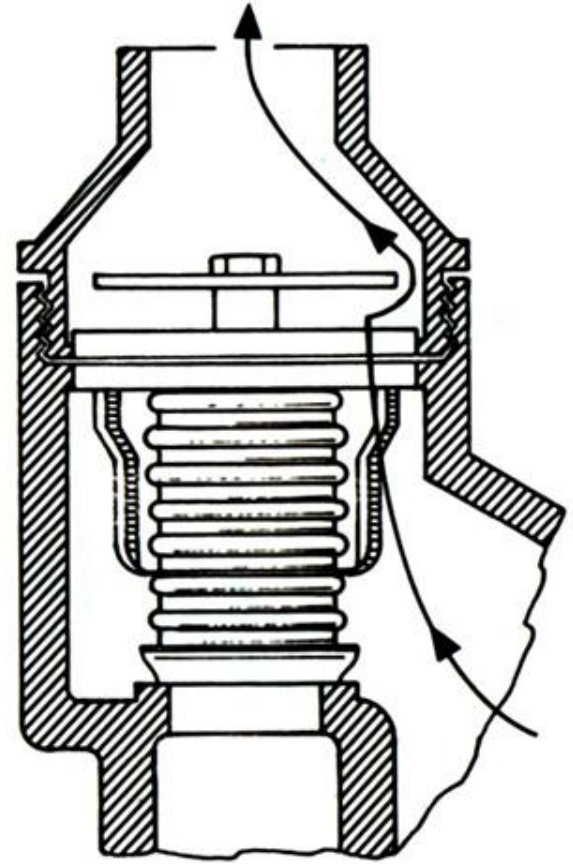
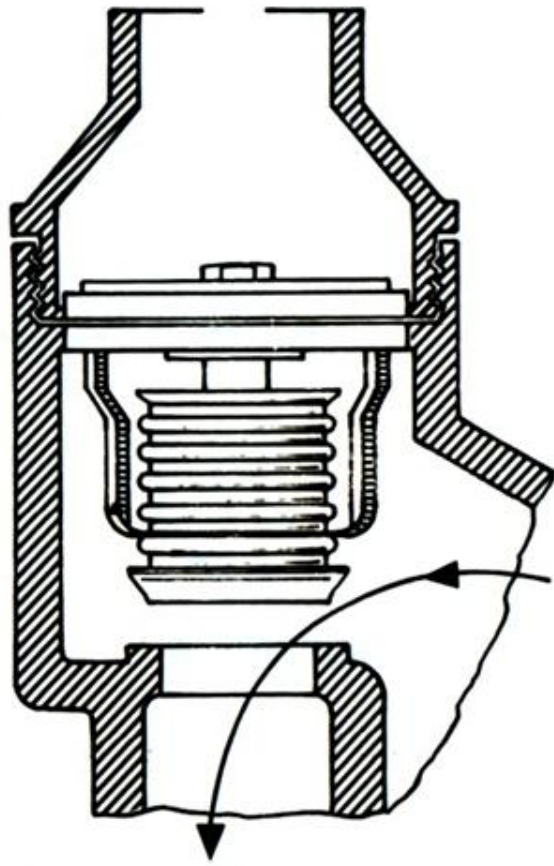

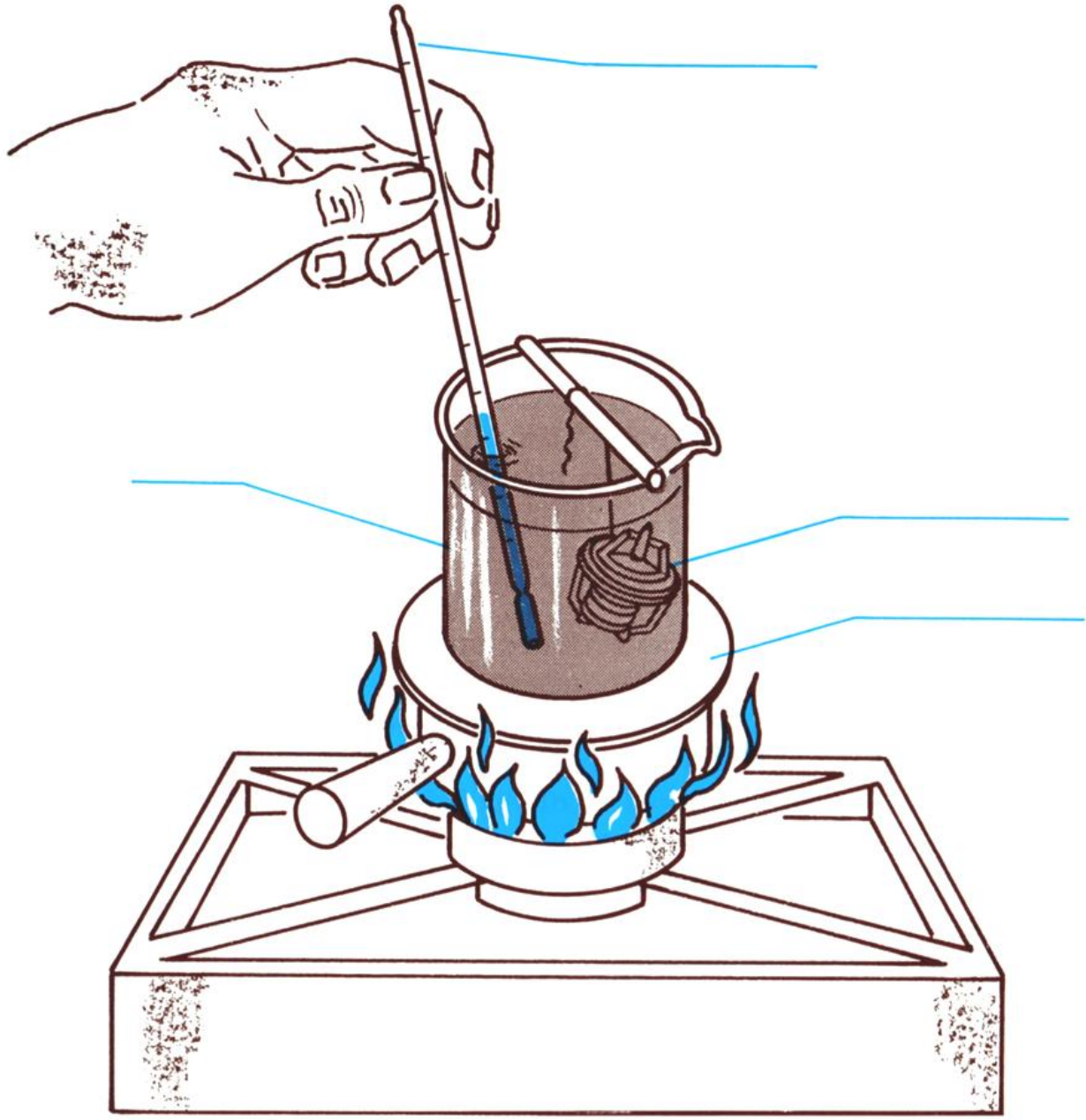

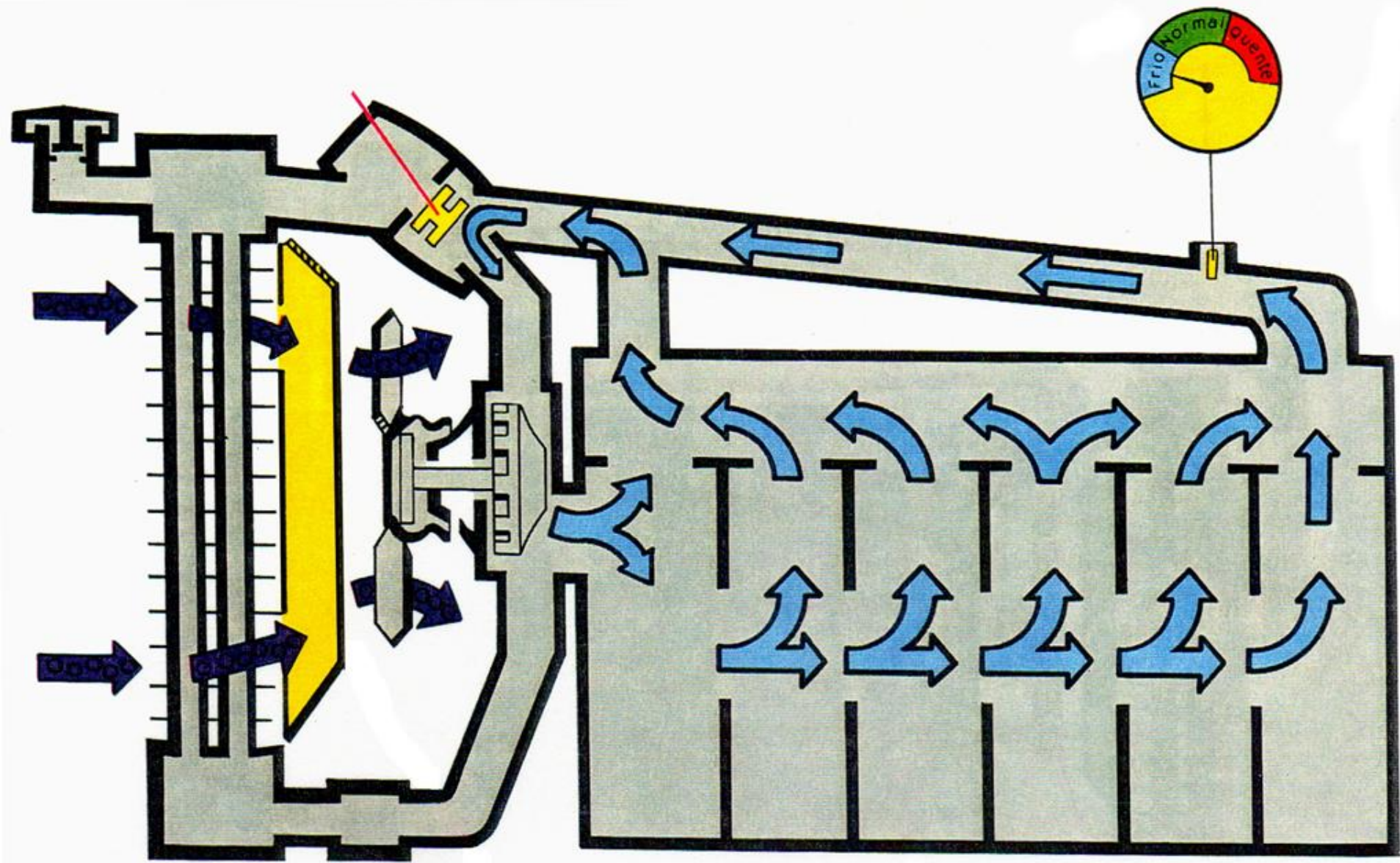

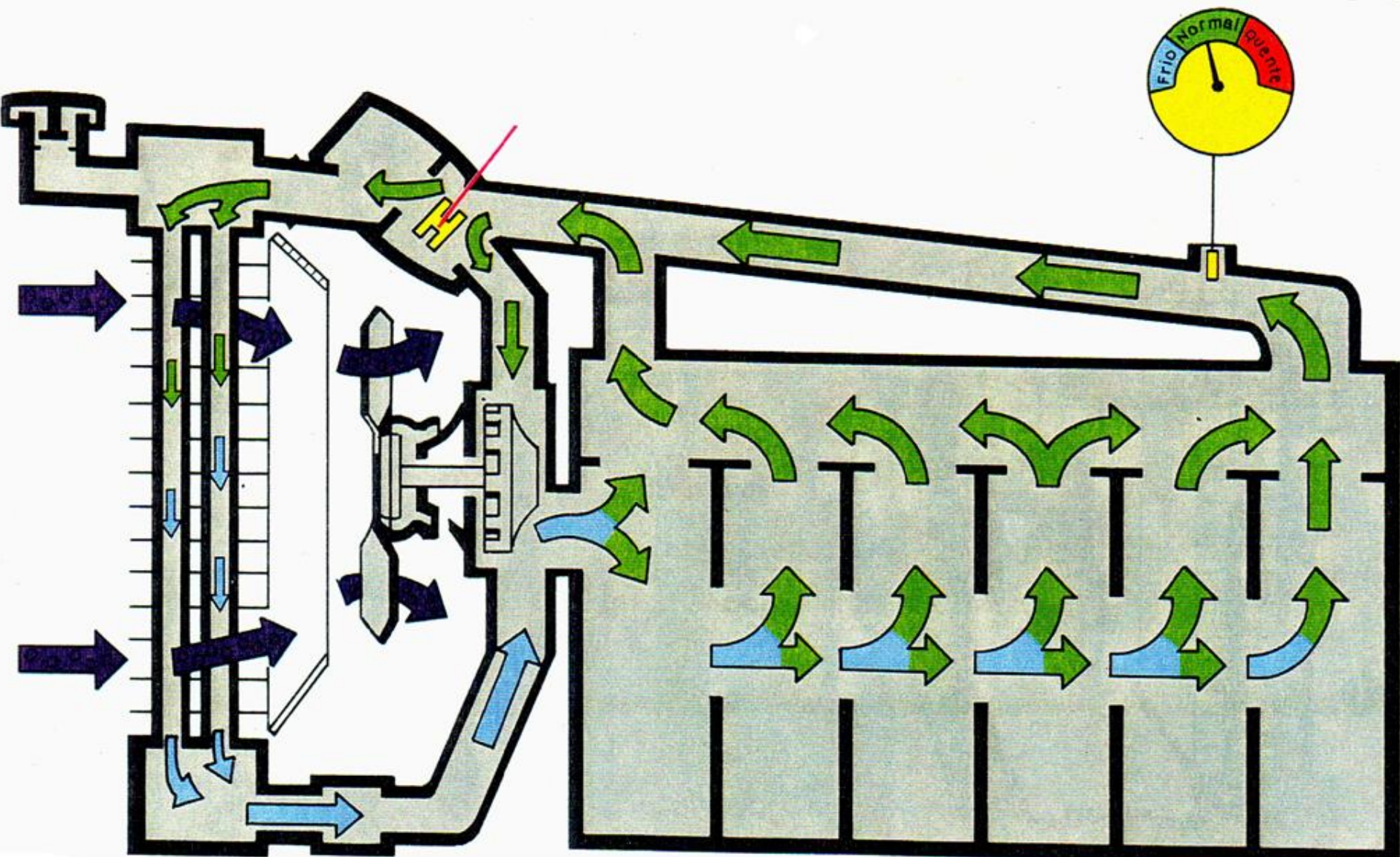

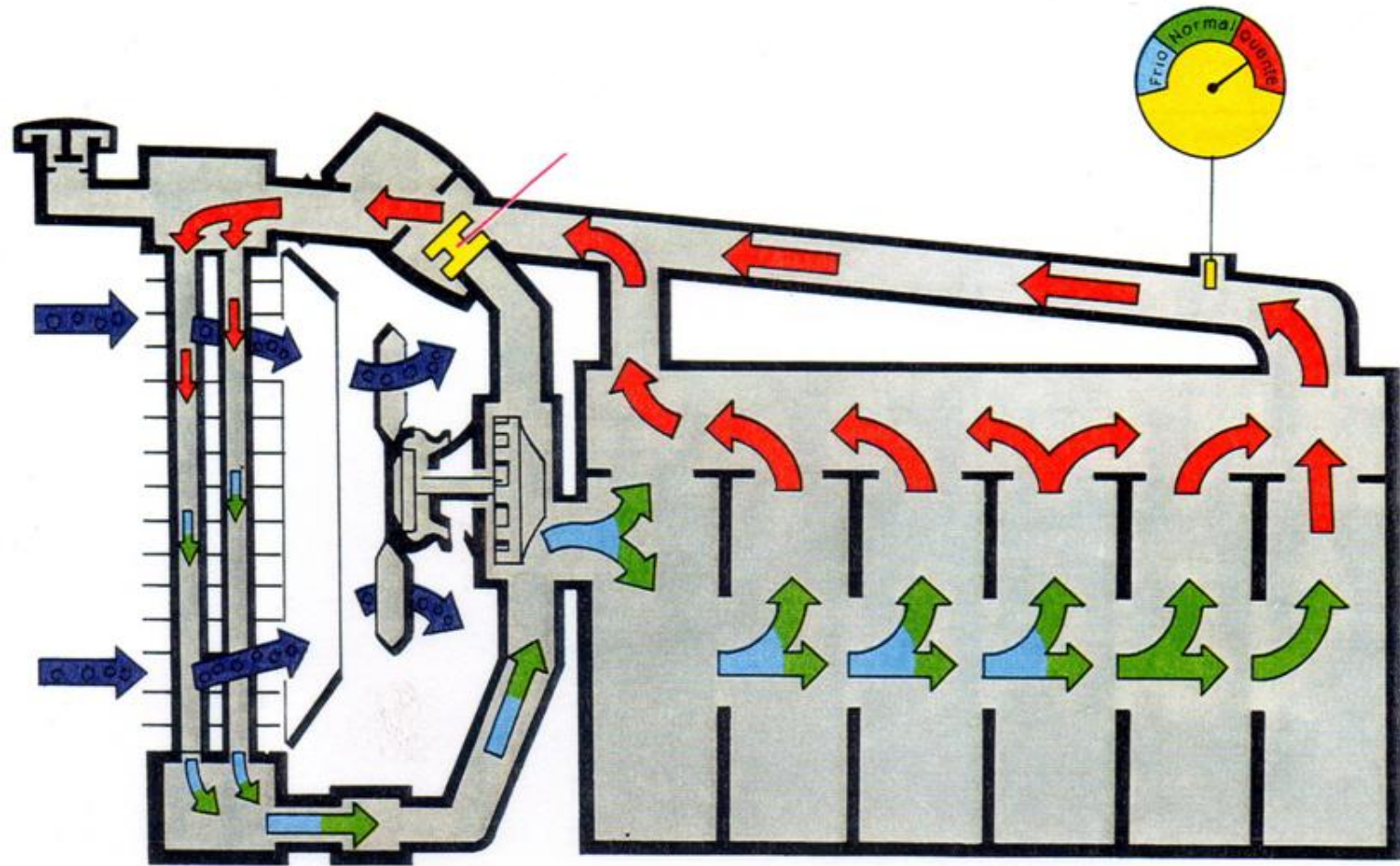

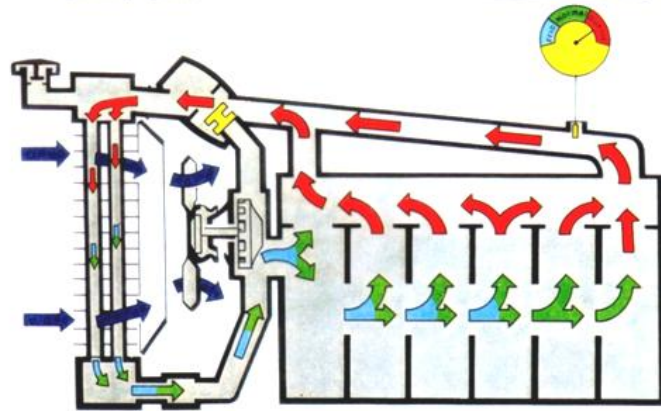
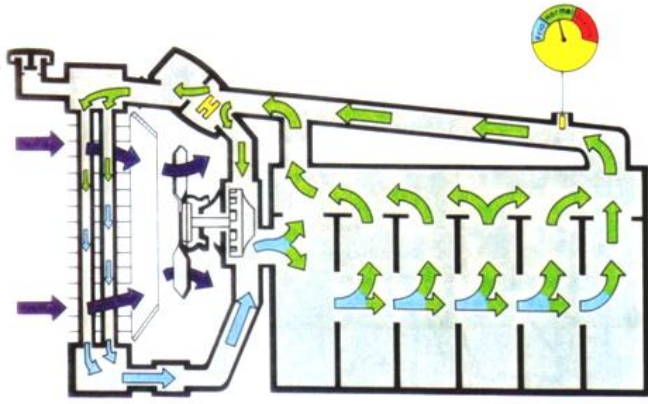
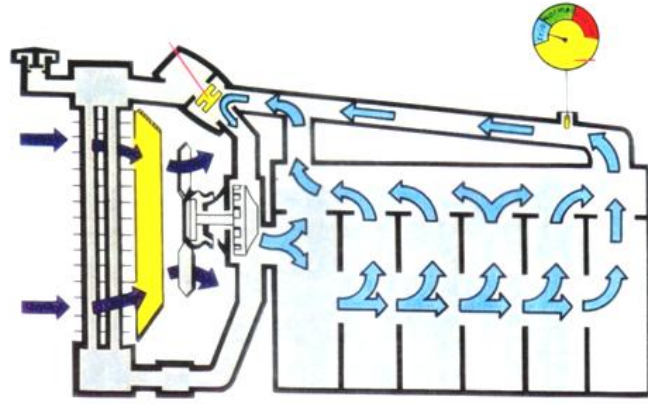

Fluidos utilizados num motor de combustão interna

1) Combustível

-Utilize combustível de boa qualidade e procedência confiável

2) Óleo

-O óleo deve estar dentro da qualidade e especificações determinadas pelo fabricante

3) Líquido de arrefecimento

-Deve se respeitar a proporção mínima de líquido especificada pelo fabricante

4) Ar

- Mantenha a manutenção dos filtro em dia, respeitando os intervalos de troca -especificados pelo fabricante.

-Sempre observe o indicador de restrição do filtro de ar.

-O filtro de ar obstruído causa perda de desempenho, aumento de consumo e elevados níveis de fumaça.