



LER 432

Máquinas e Implementos Agrícolas

Mecanização e a agricultura de precisão

José P. Molin
ESALQ/USP
jpmolin@usp.br

Laboratório de Agricultura de Precisão
www.agriculturadeprecisao.org.br

Objetivo

Expor o contexto que envolve a agricultura de precisão, a sua conceituação, ferramentas envolvidas e a sua forte interação com as operações mecanizadas

BIBLIOGRAFIA

BRASIL. Agricultura de Precisão. 36p. 2013
(Boletim Técnico)

(www.agriculturadeprecisao.org.br)

MOLIN, J. P., AMARAL, L. R., COLACO, A. F.
Agricultura de precisão. São Paulo : Oficina
de Textos, 2015, 238p.

O que é Agricultura de Precisão?

AP é gerenciar o sistema considerando que **as lavouras não são uniformes.**

Milho (kg ha⁻¹)

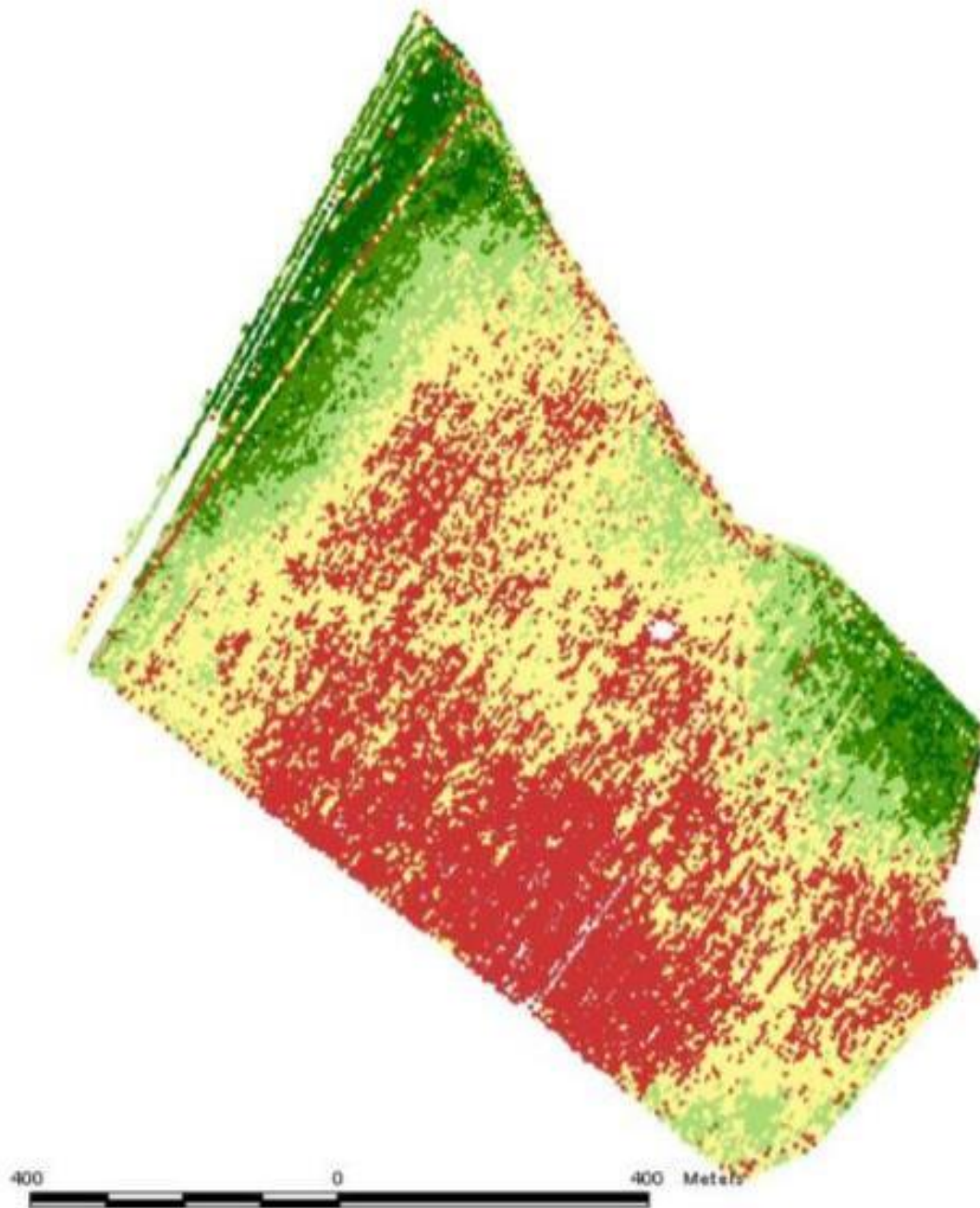

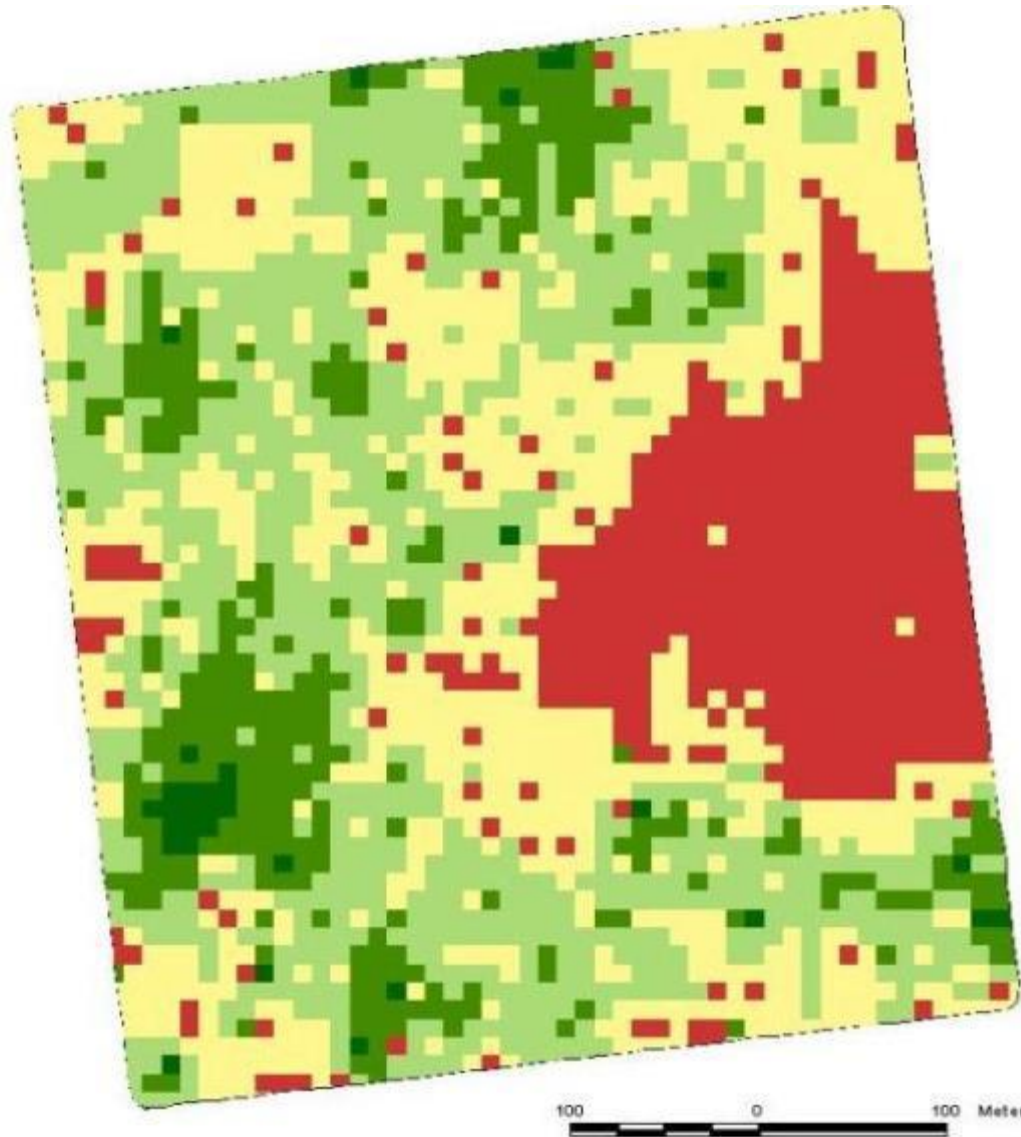

Citros

Cana

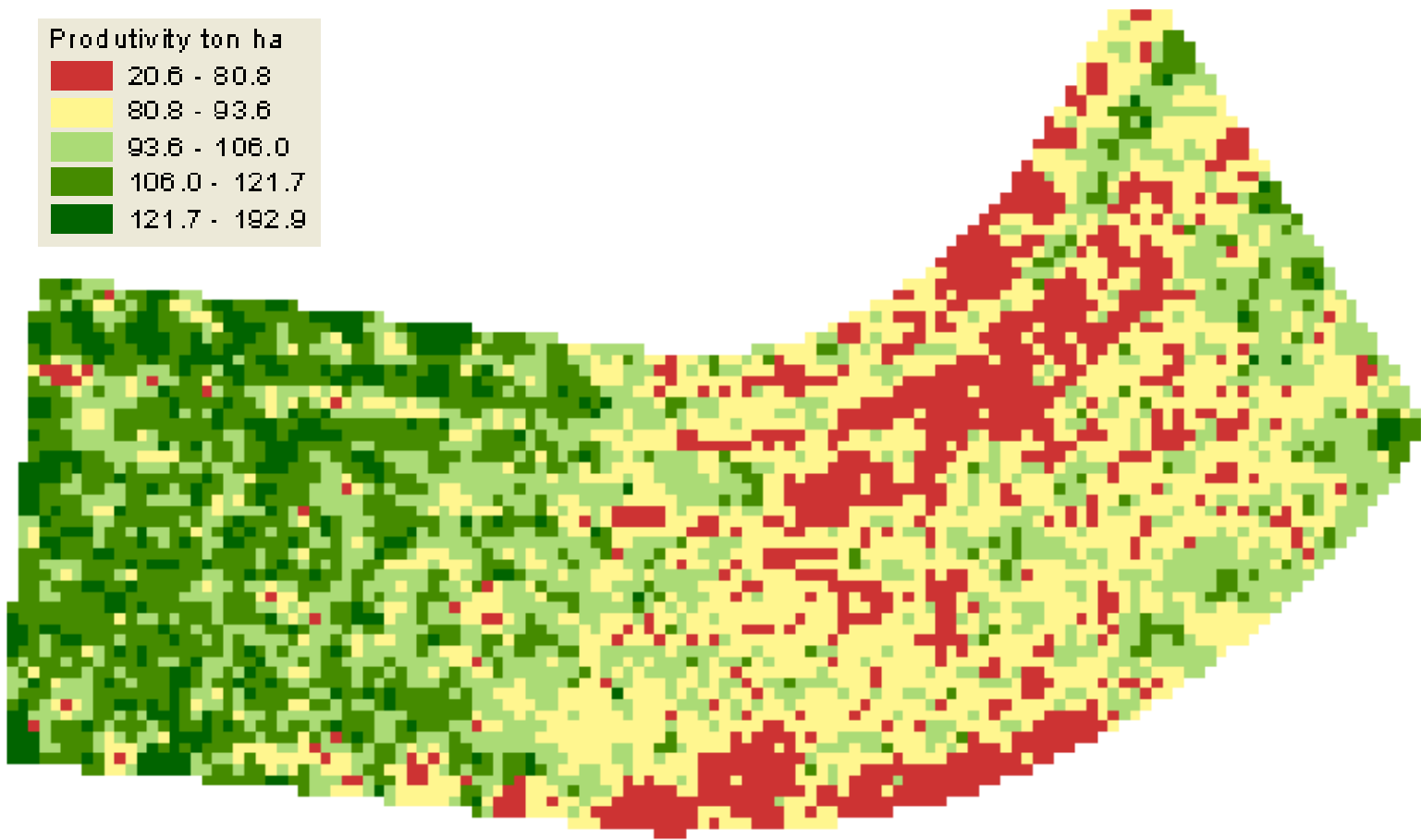
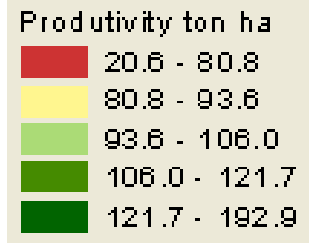

Café

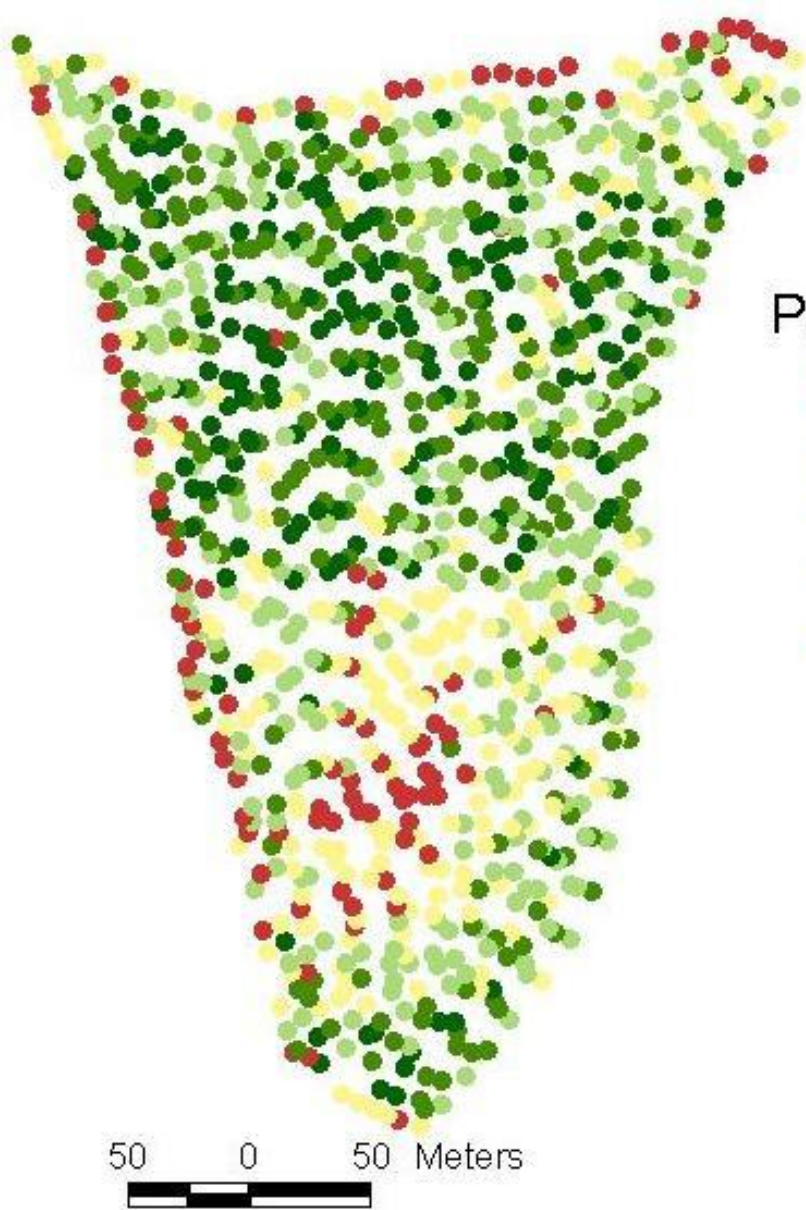

Produtividade kg/ha

- 1119.6 - 2335.2
- 2335.2 - 3055.8
- 3055.8 - 3632.4
- 3632.4 - 4182
- 4182 - 4983



Produtividade de café- sc/ha

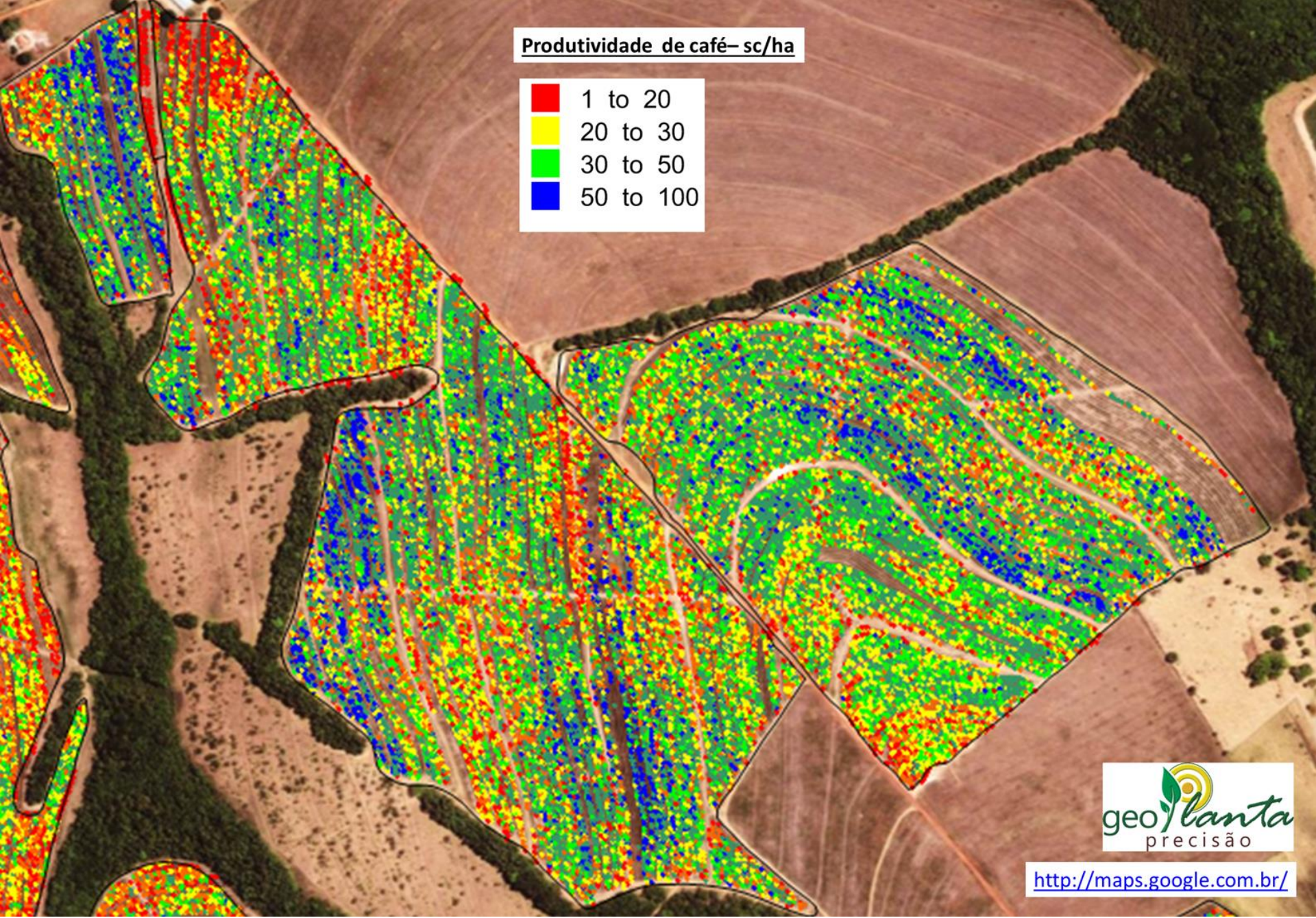

<http://maps.google.com.br/>

Uma definição simples:

AP é **gerenciar** o sistema de produção **considerando a variabilidade** espacial e temporal das lavouras...

...e **tirar proveito** (econômico, ambiental) dessas desuniformidades...

...sempre que elas forem relevantes.

As duas grandes vertentes da AP

- Variabilidade espacial
 - Investigação e mapeamento (amostragens, sensores e SIG)
 - Gestão (uso de insumos localizados e em taxas variáveis)
- Tecnologias relacionadas ao GNSS
 - Sistemas de direcionamento, telemetria, controle de tráfego, automações como o controle automático de sessões, etc... (“automação das máquinas”)

Os componentes necessários

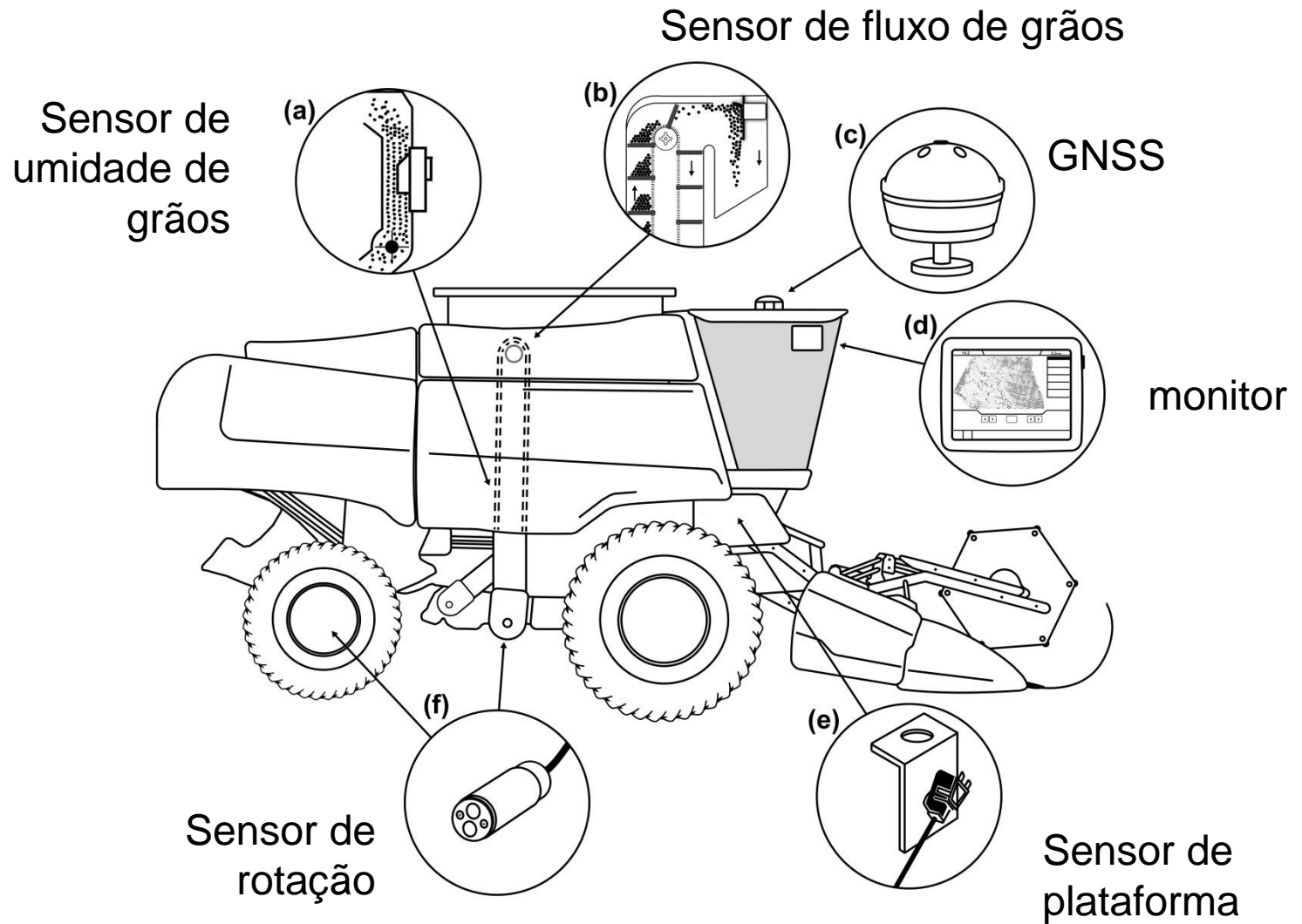

Sensores gravimétricos

Elevador de taliscas

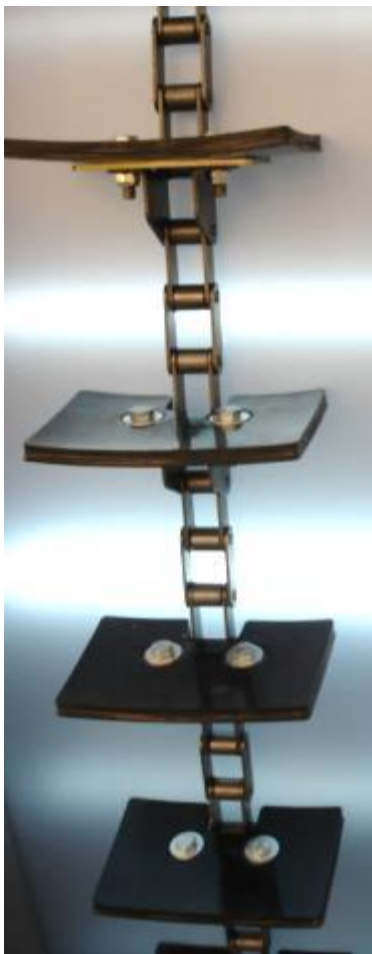

<http://www.agleader.com>

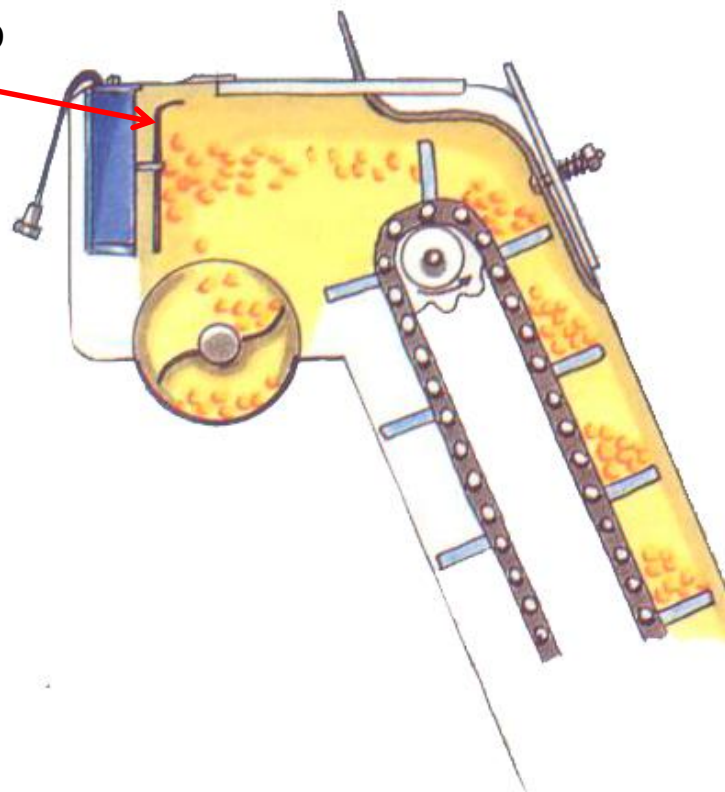

Profi





Sensores de umidade dos grãos



Sensores volumétricos

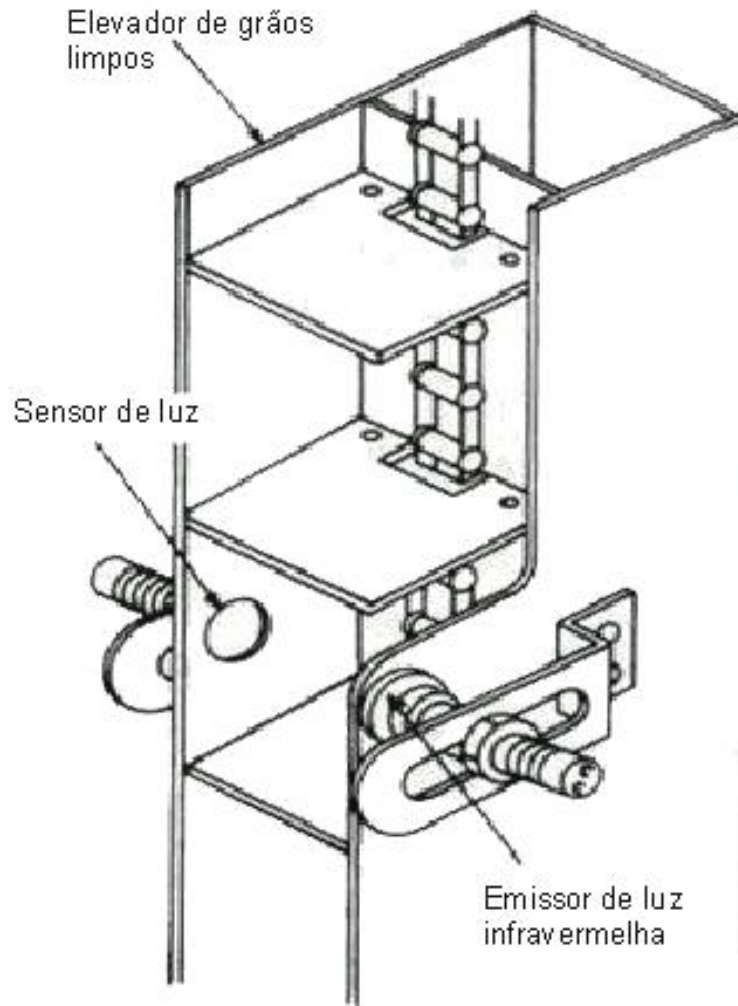

Sensor óptico

RDS

Sensor óptico

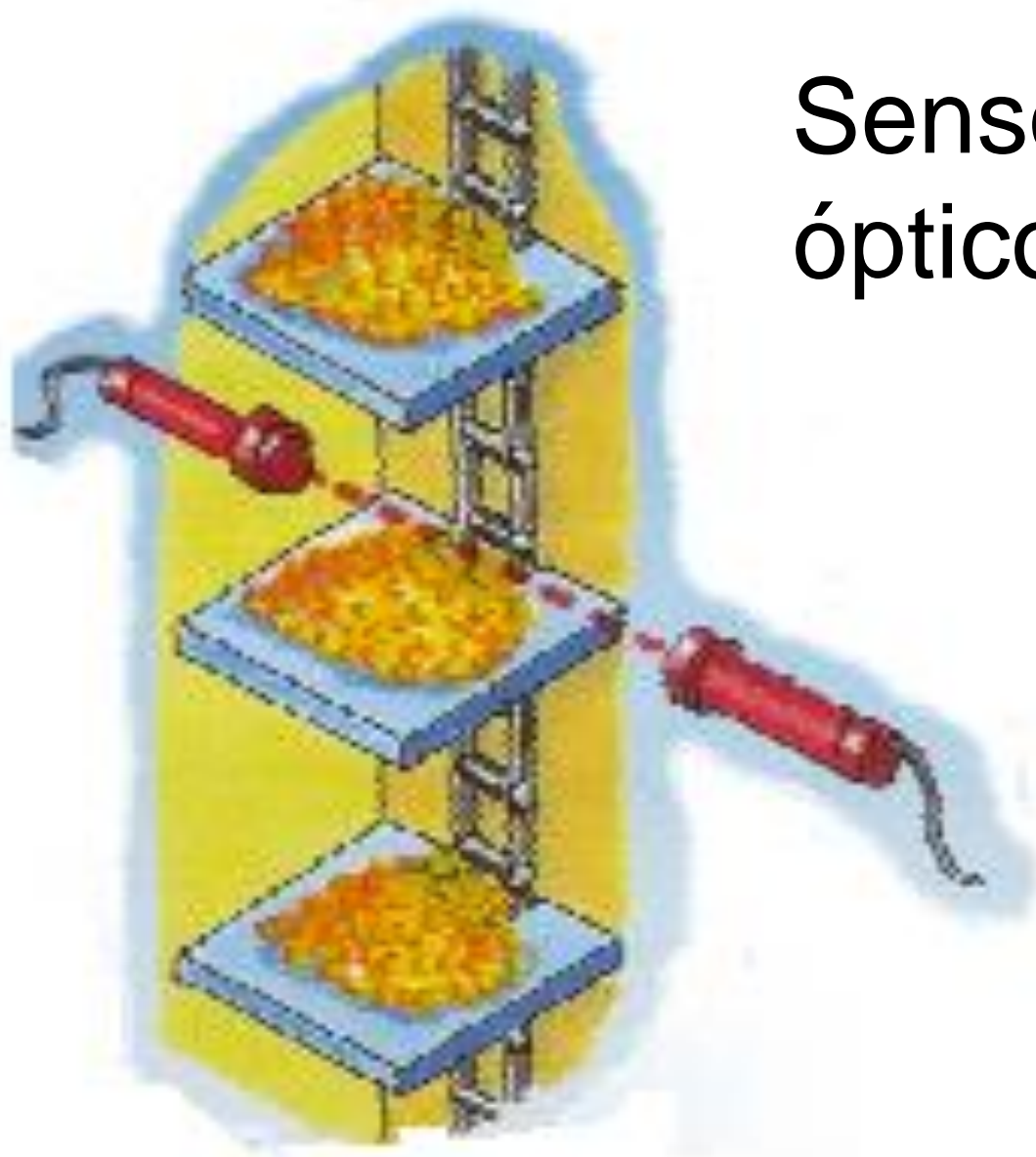

O mapa básico (de “pontos”) é a representação de cada ponto amostral

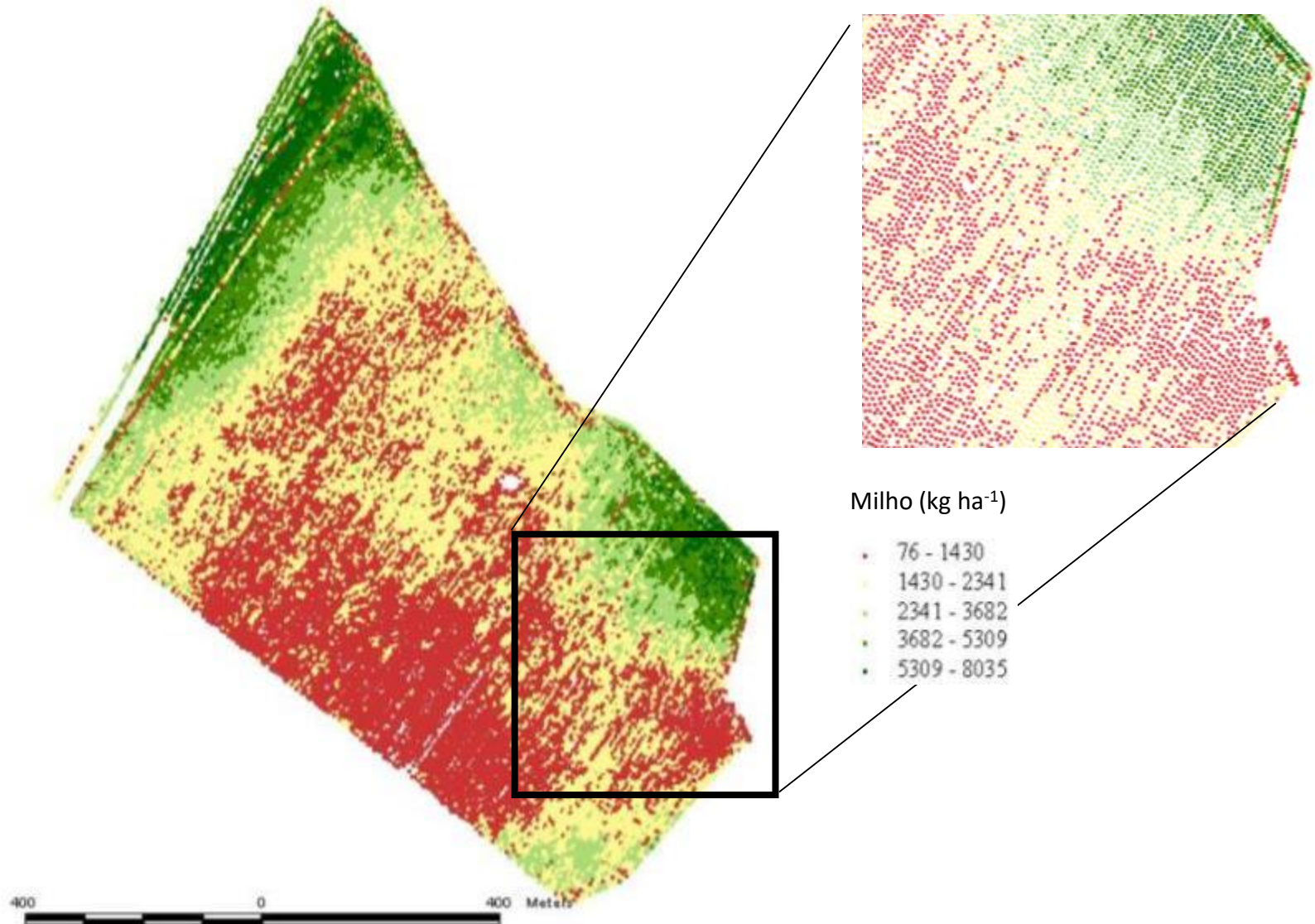

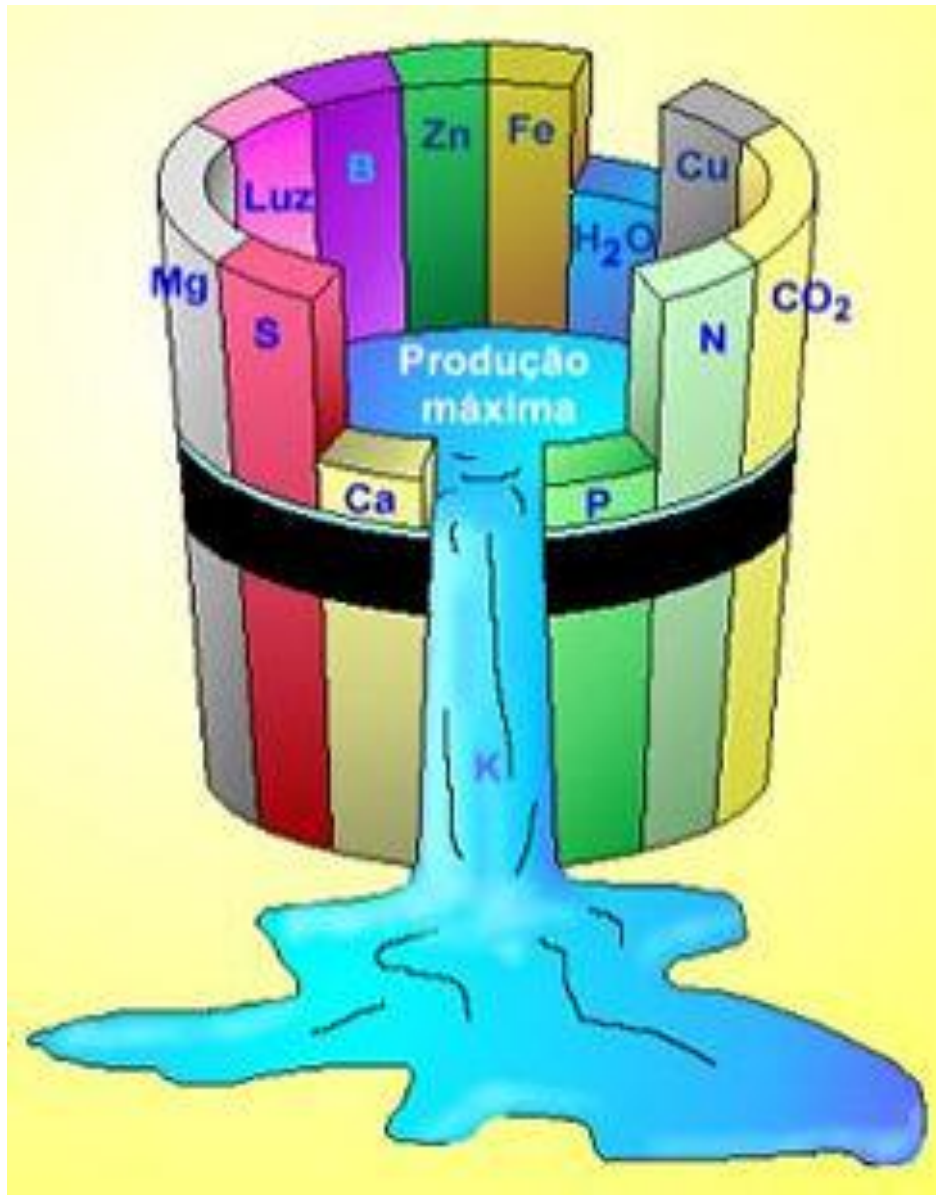

Amostragem georreferenciada (foco na fertilidade do solo)

Visa regularizar os teores no solo, tendo como foco a Lei dos Mínimos (especializada).

Amostragem de solo (e outros) “em grade”

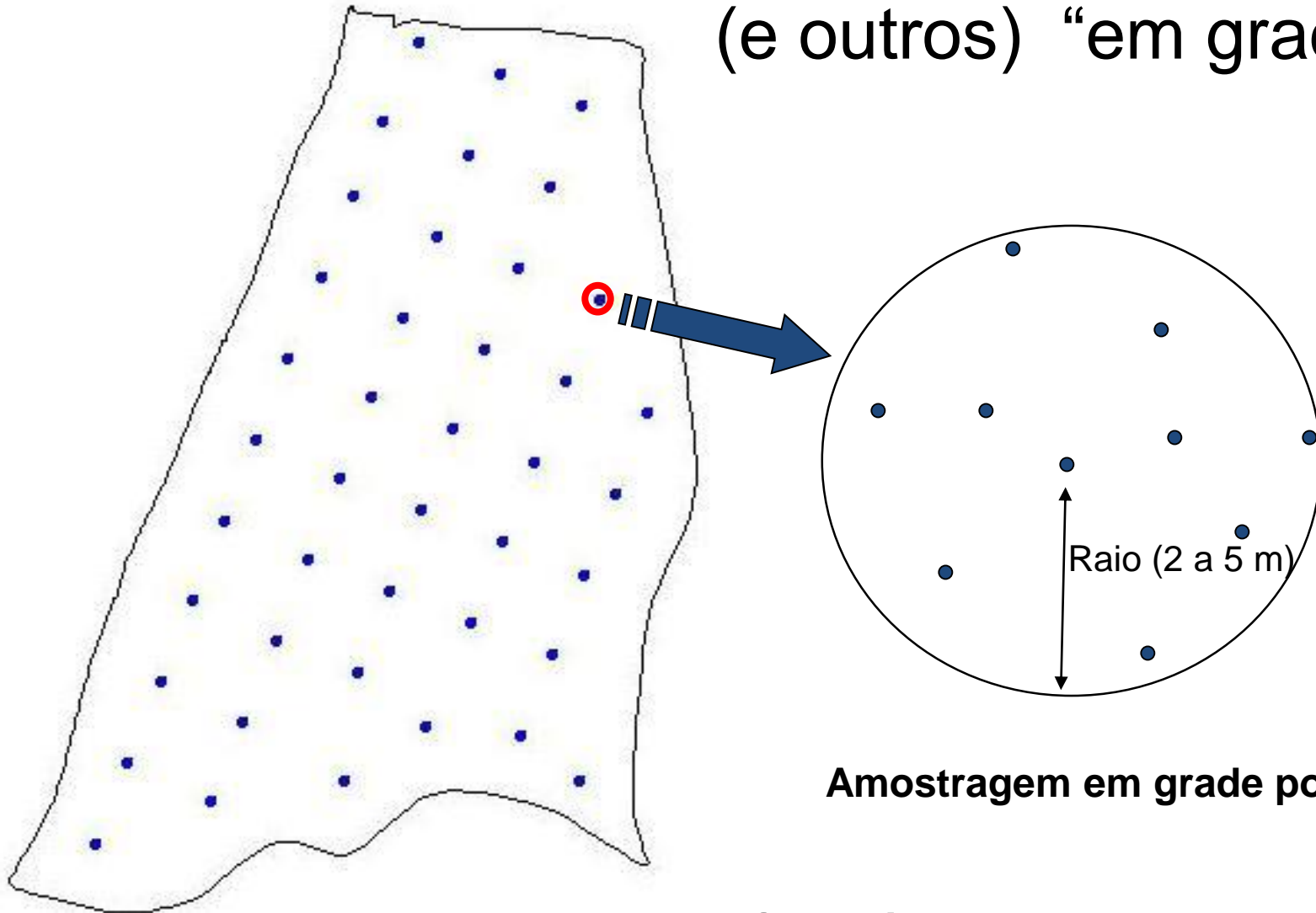

Amostragem em grade por ponto

Qual é a densidade amostral?



Amostragens



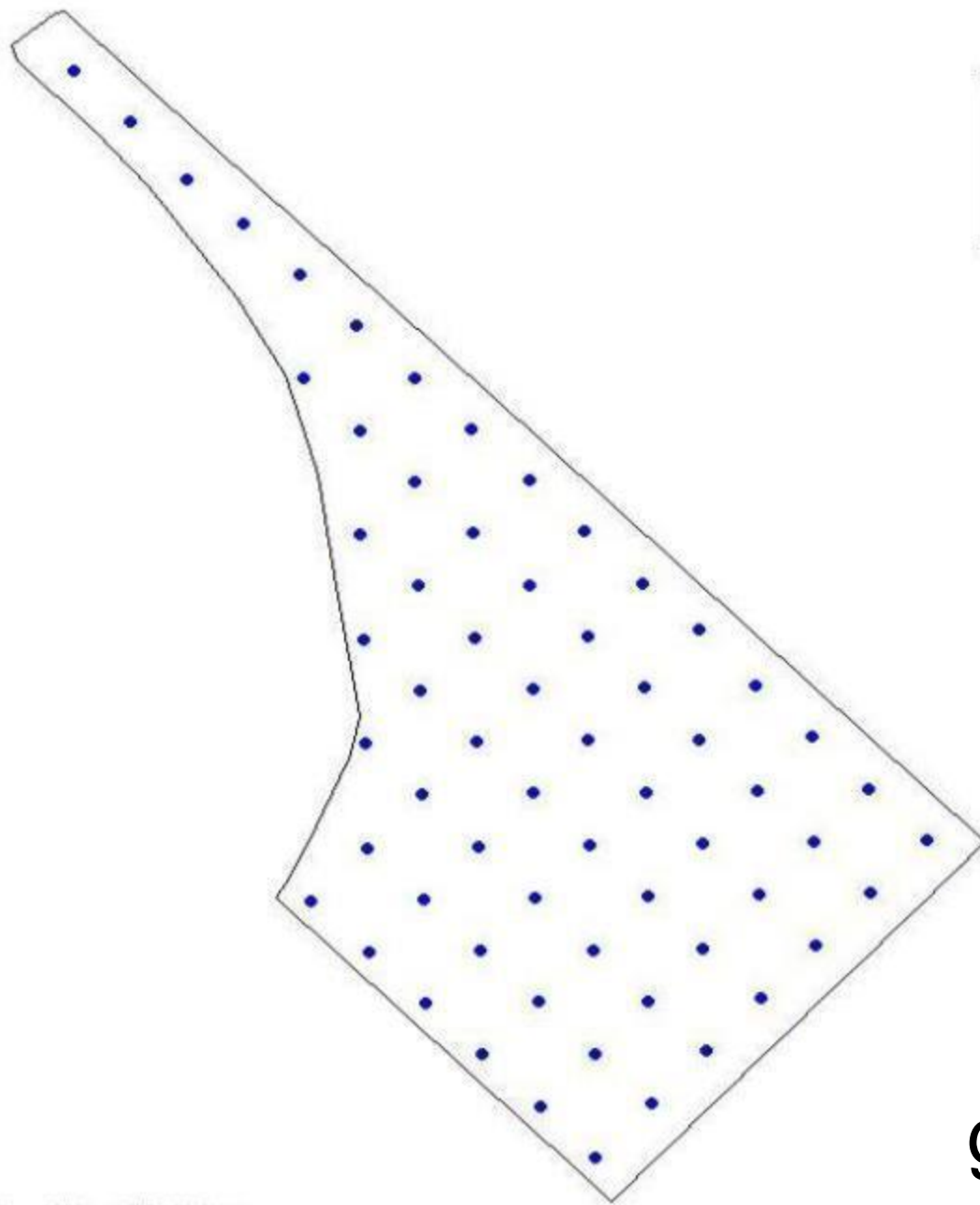

□ (302.2ha.) Field Boundary
• Pontos

O processo de amostragem e geração de mapas



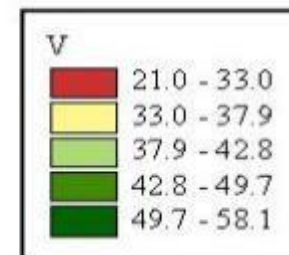
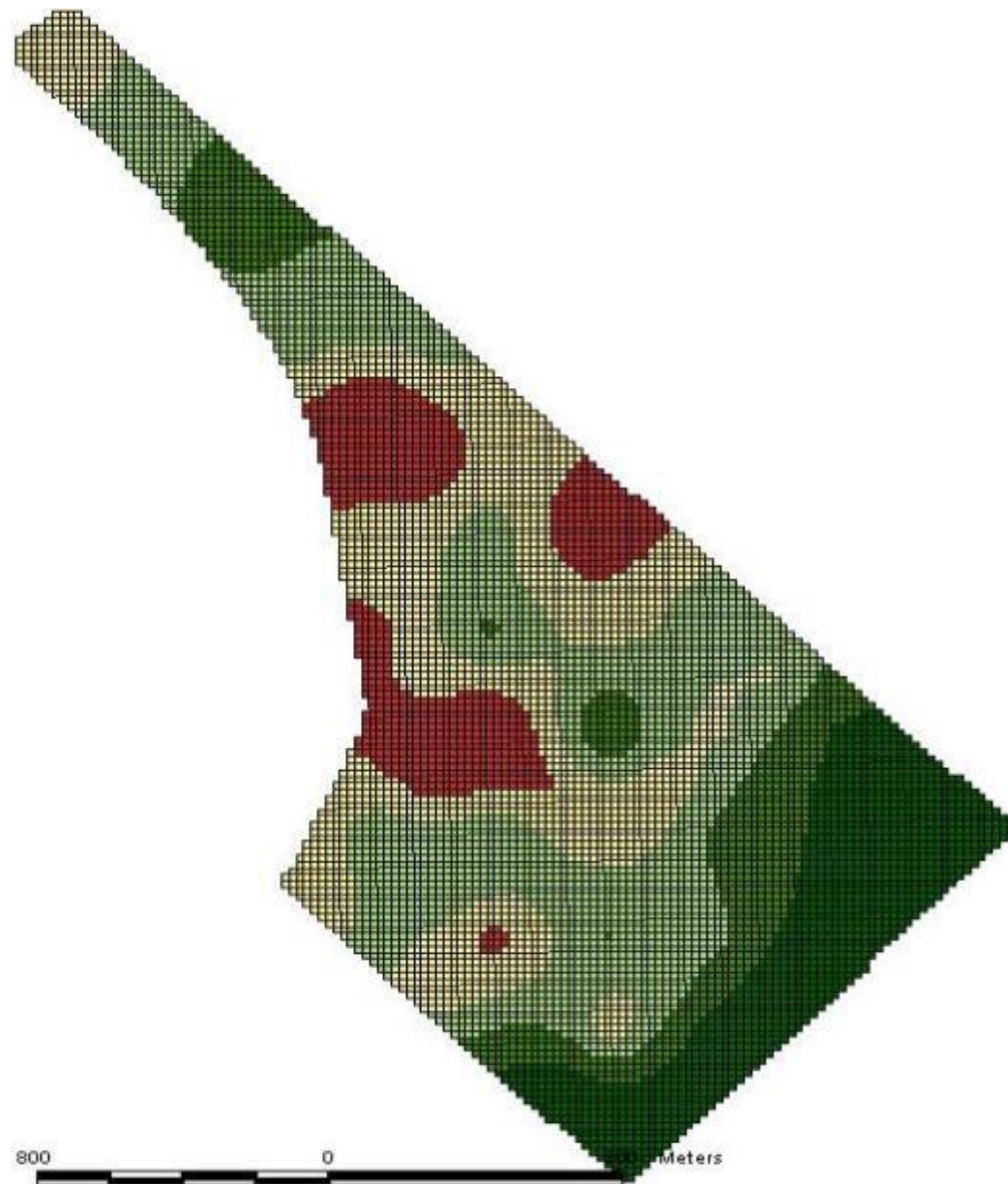

800 0 Meters



o 302.2 ha



Calcario recomendado	
Red	200 - 667 kg/ha
Yellow	668 - 1267 kg/ha
Light Green	1267 - 1787 kg/ha
Medium Green	1787 - 2274 kg/ha
Dark Green	2274 - 3465 kg/ha

Sensores & sensoriamento

Função: produzir diagnósticos detalhado das lavouras, de forma indireta, porém em alta densidade

- Os alvos?
 - Solo
 - Plantas
 - Produto (quantidade e qualidade)

- Formas (~~nomenclatura usual~~)?

- ~~Sensoriamento remoto~~

- Sem contato com o alvo

- ~~Sensoriamento direto~~

- Contato físico com o alvo

} terminologia recente:
sensores proximais
("proximal sensors")

Sensores de solo

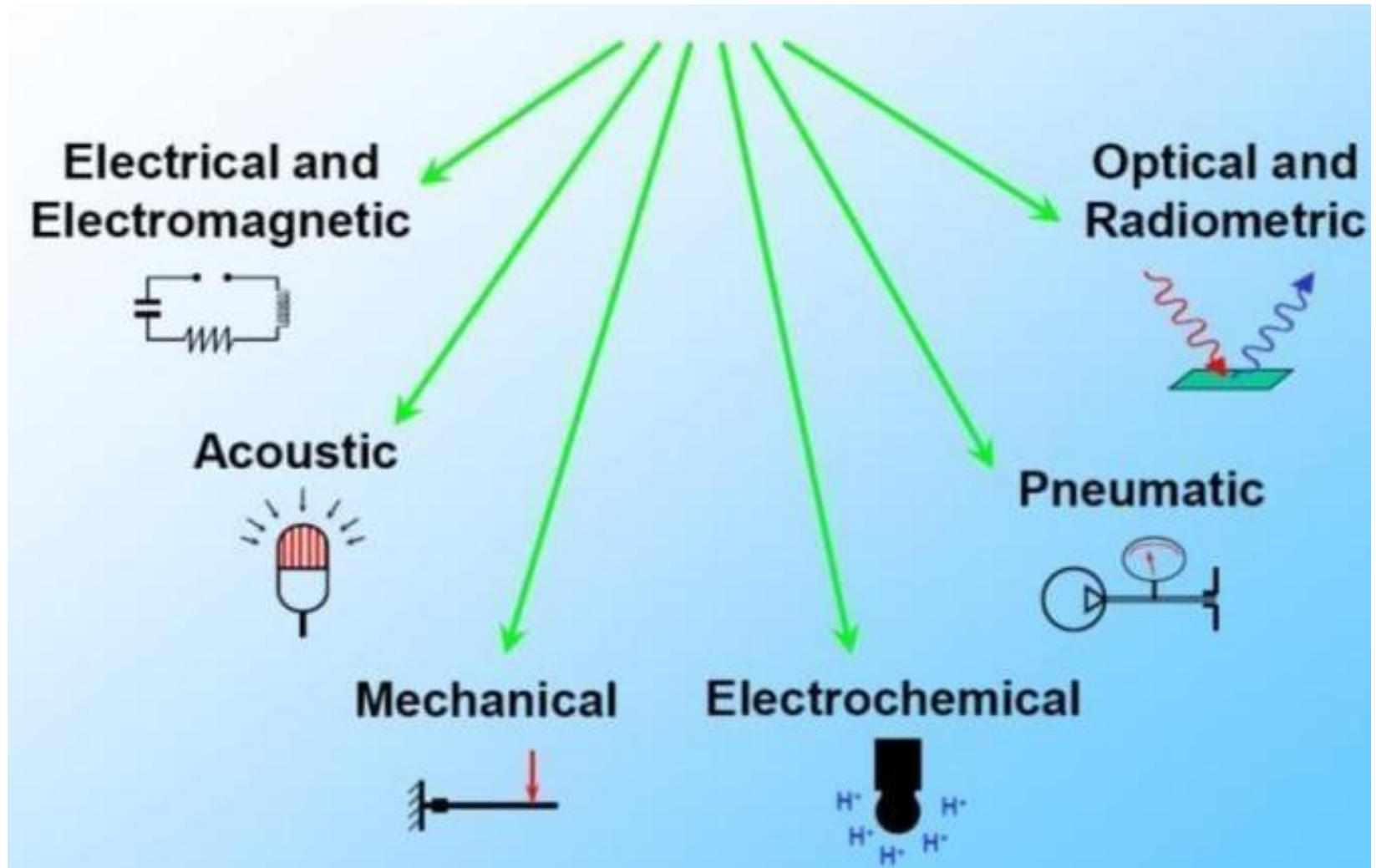

ADAMSHUK (2007)

Condutividade elétrica aparente do Solo (CEa)

Há duas formas de se medir :

- Por contato direto
- Indução eletromagnética

Sensor de condutividade elétrica do solo por contato

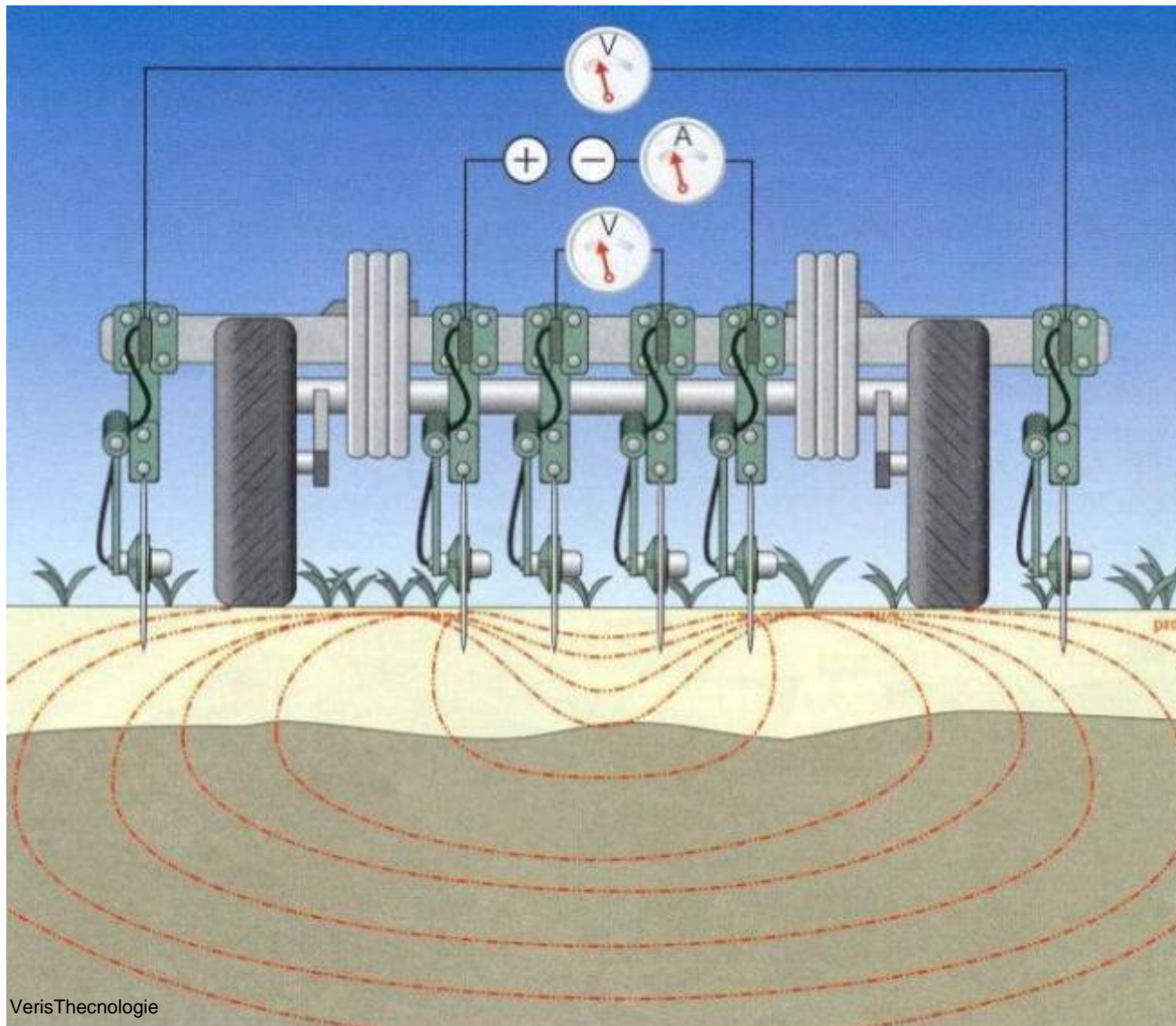



Sensor de condutividade elétrica do solo por indução



Geoplanta.com.br



<http://www.geophysical.com/profiler.htm>

Profiler EMP 400



EC (mS m^{-1})

Soil moisture (%)

Clay content (%)

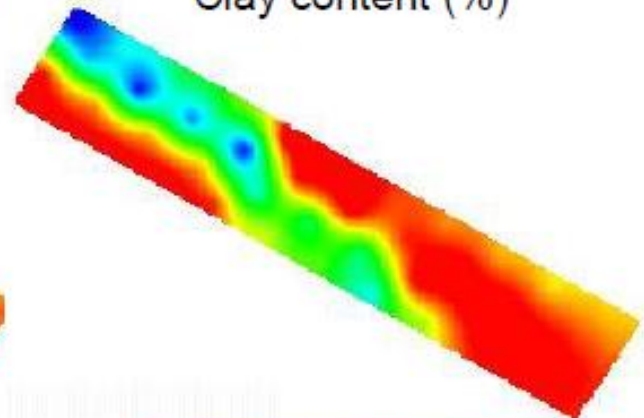
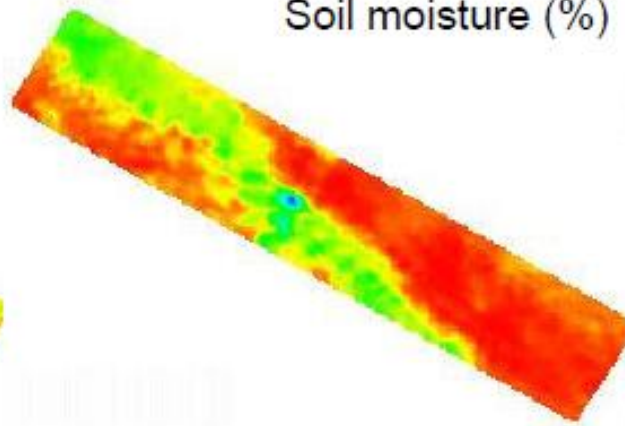
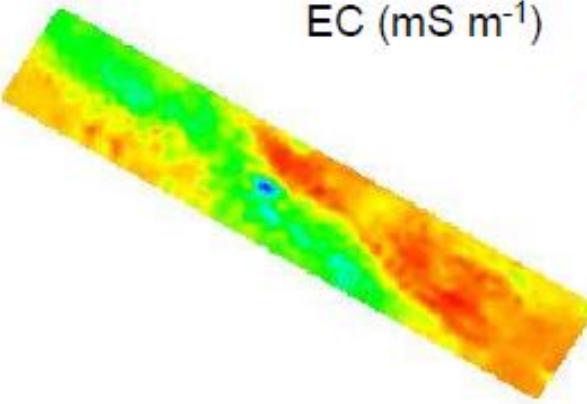

MOLIN & FAULIN, 2011

Sistema sensor de pH



...é o mais próximo do conceito
de laboratório no campo

Como funciona ...



A haste amostradora desce até o solo

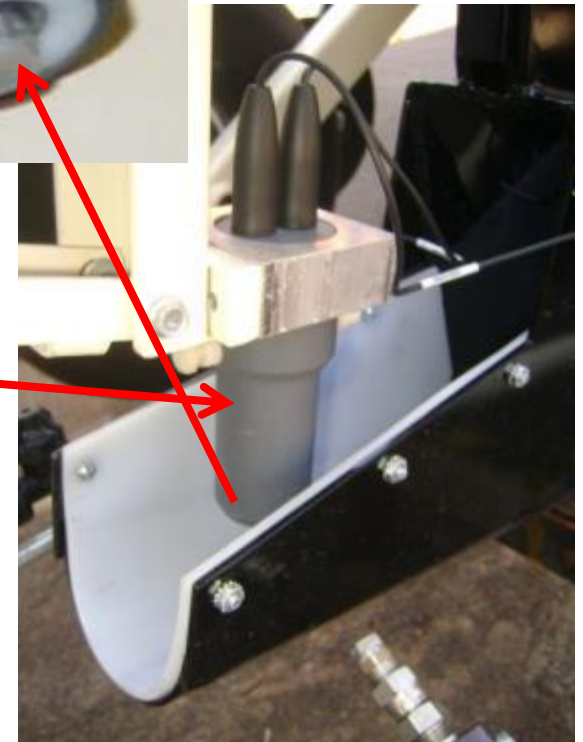

A amostra de solo é empurrada contra dois eletrodos de pH que fazem a leitura



Os dados são então georreferenciados

Espectrorradiometria de campo

Correlation to soil tests

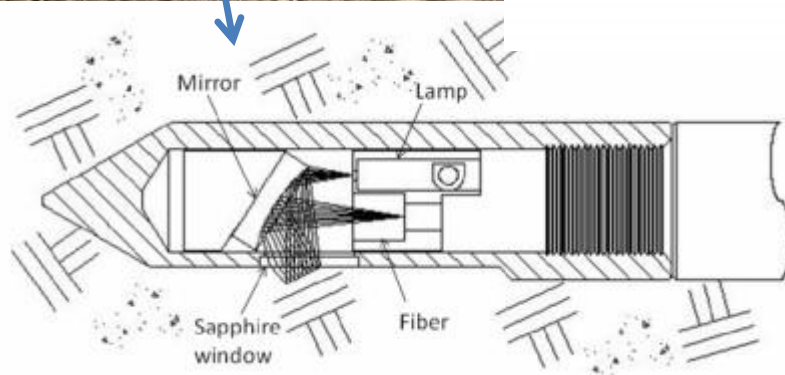
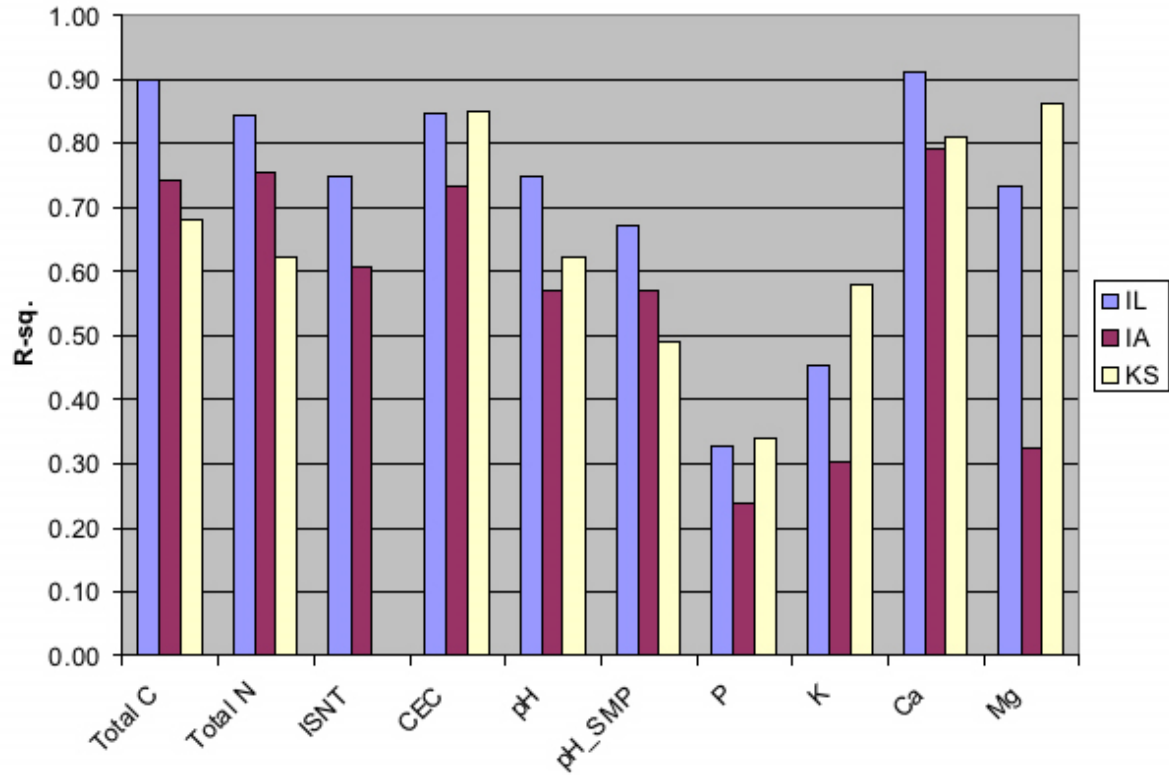

Vista de baixo do sensor

Lab tests

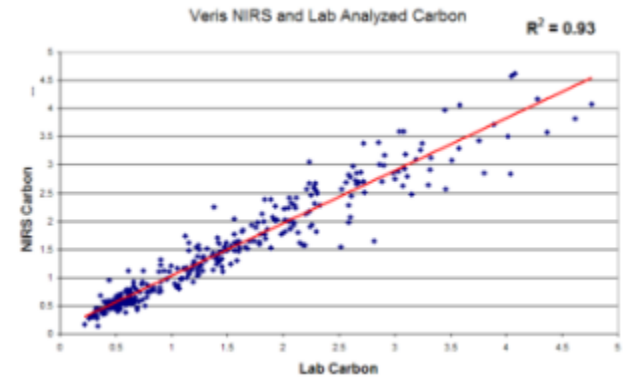

Sensores de plantas

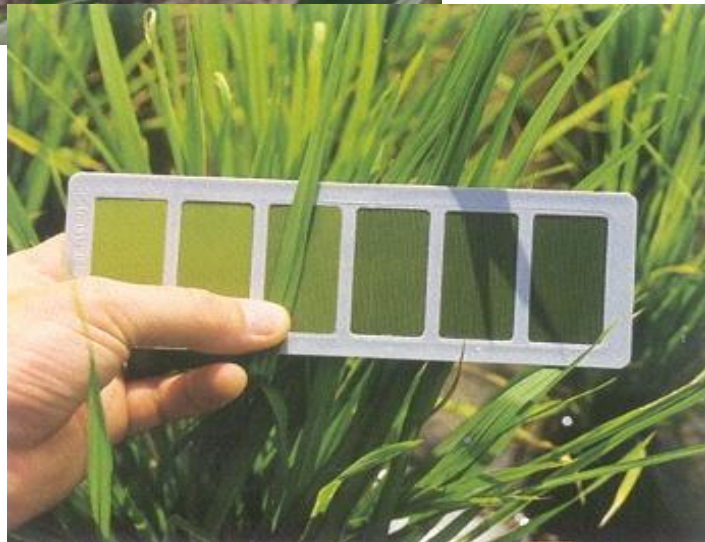

... predominantemente ópticos



Níveis de aquisição de dados – essencialmente estimativa de biomassa



Orbital

www.google.com.br



Aéreo (avião)



Aéreo ("VANT")



Terrestres

Ativos!

Sensores de plantas

Exemplo de reflectância de uma cultura

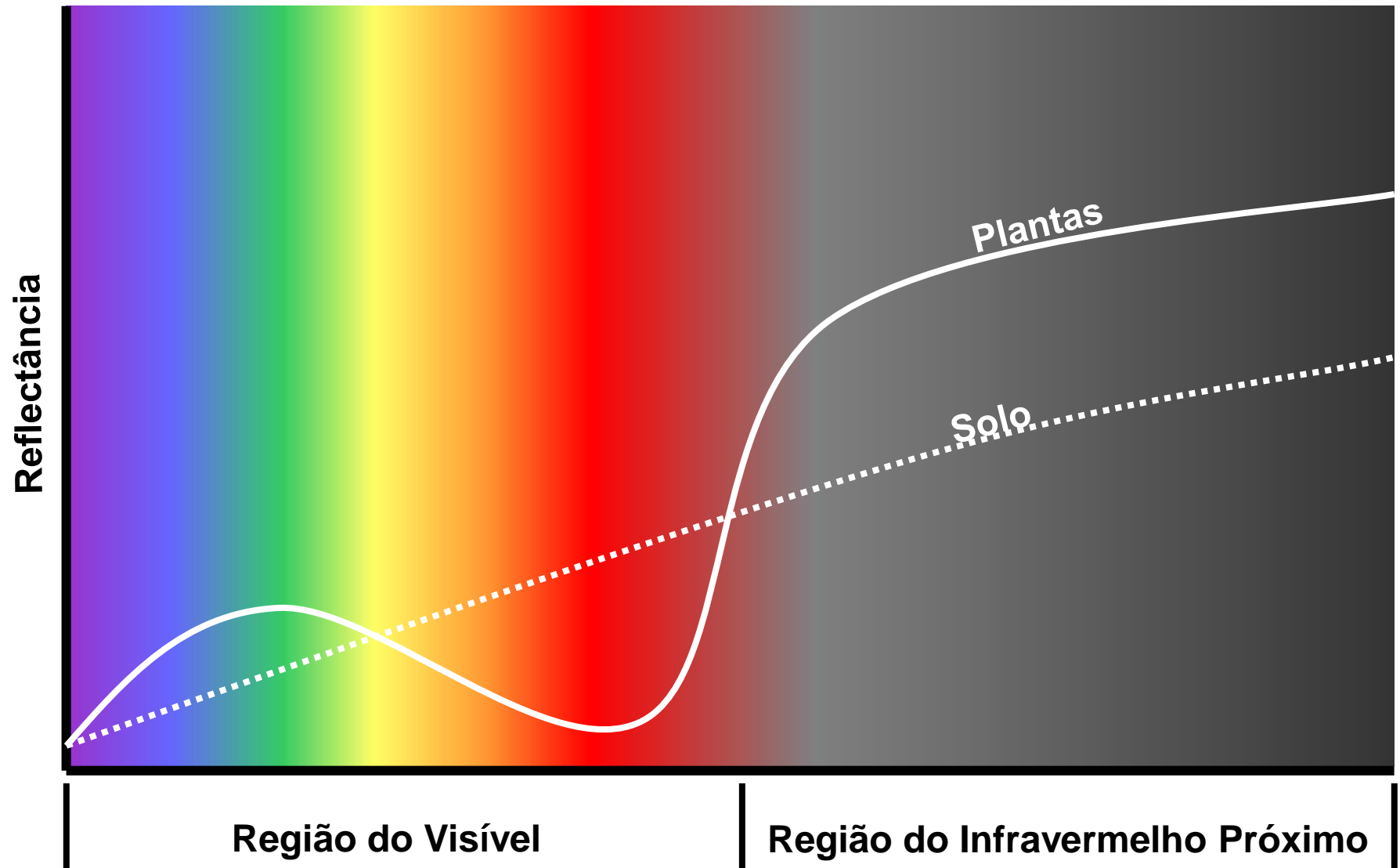

Sensores de plantas

Sensores multiespectrais passivos



WERNER, A. (2008)

Sensores
multiespectrais

Ativos



Sensores multiespectrais ativos



Yara N-Sensor





A mecanização e a automação

*aplicação governada por sensor

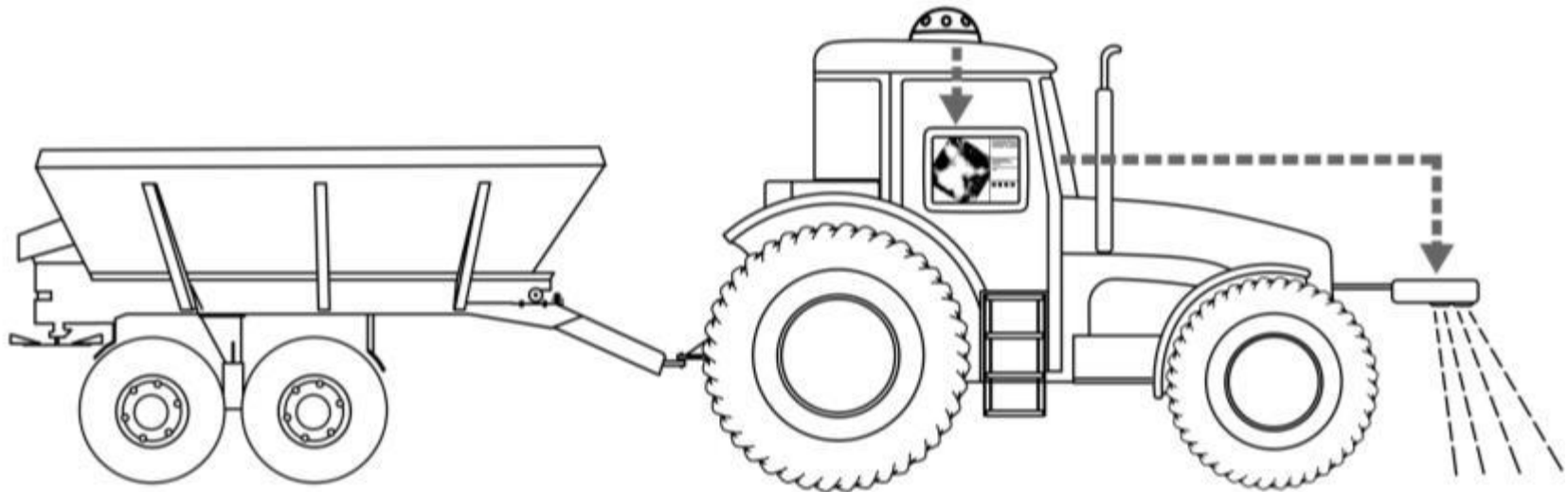

A mecanização e a automação

*aplicação governada por mapa



Distribuidor a Lanço

Atuadores

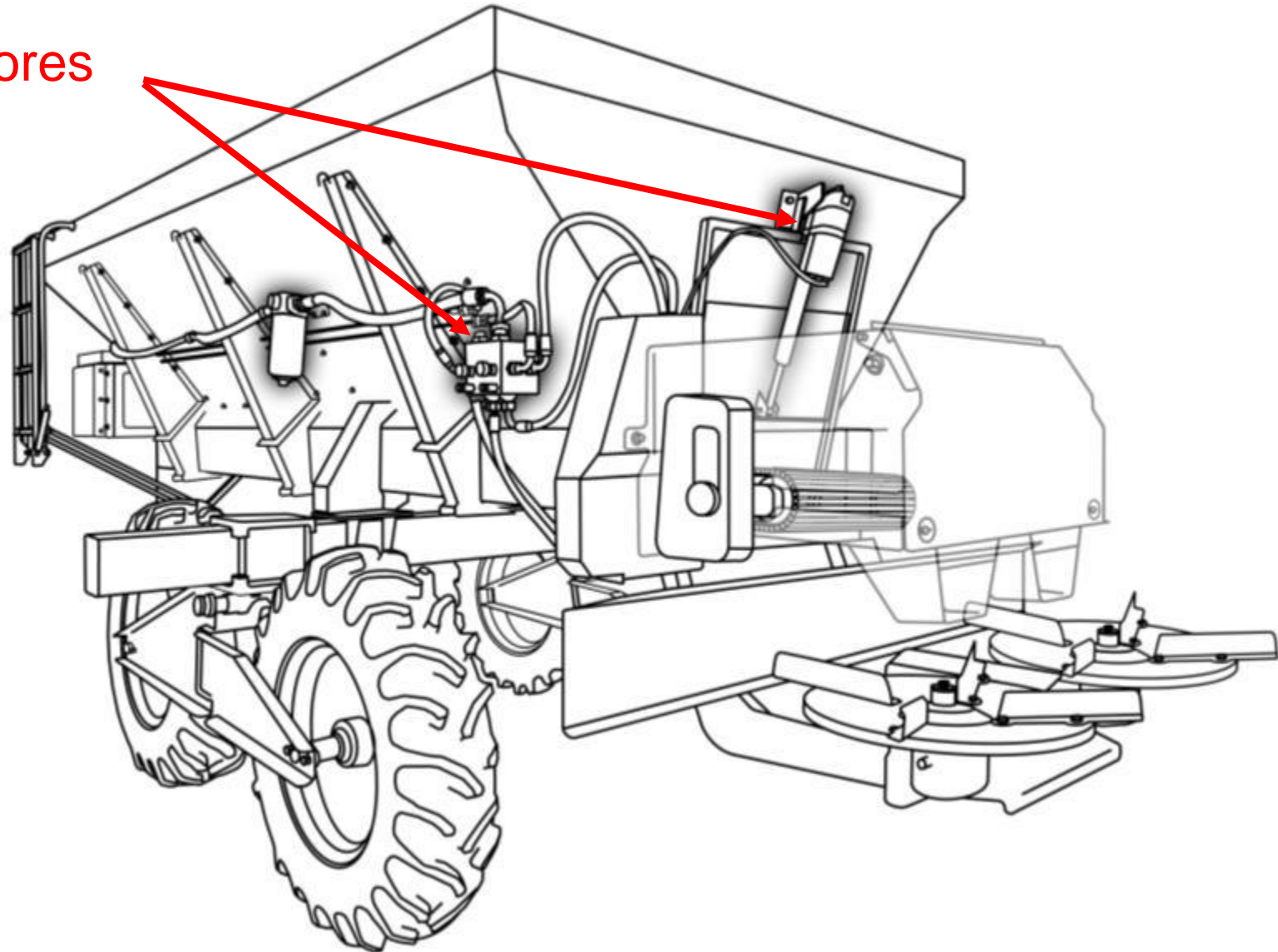

A mecanização e a automação

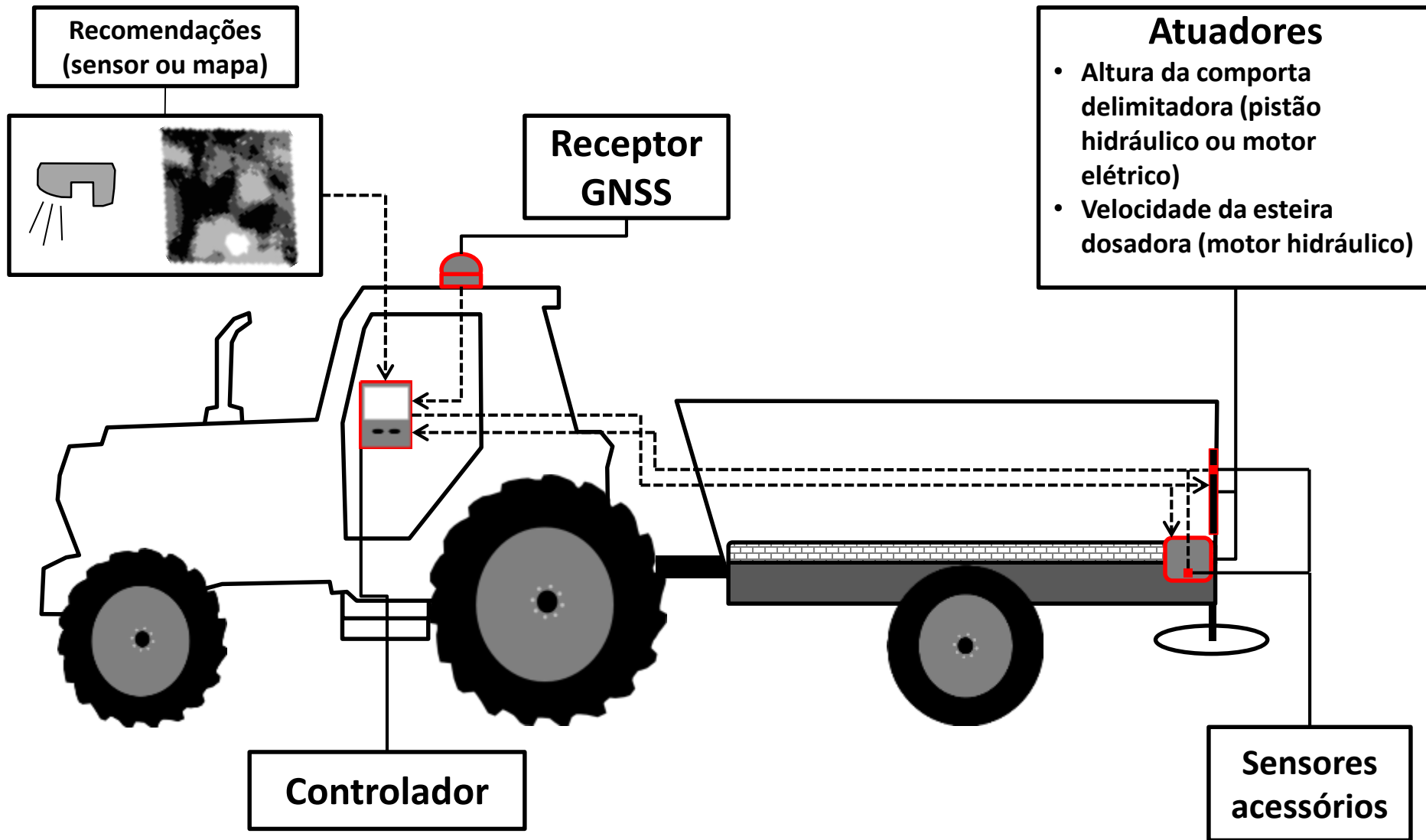

**Recomendação
KCI**

KCI Aplicado

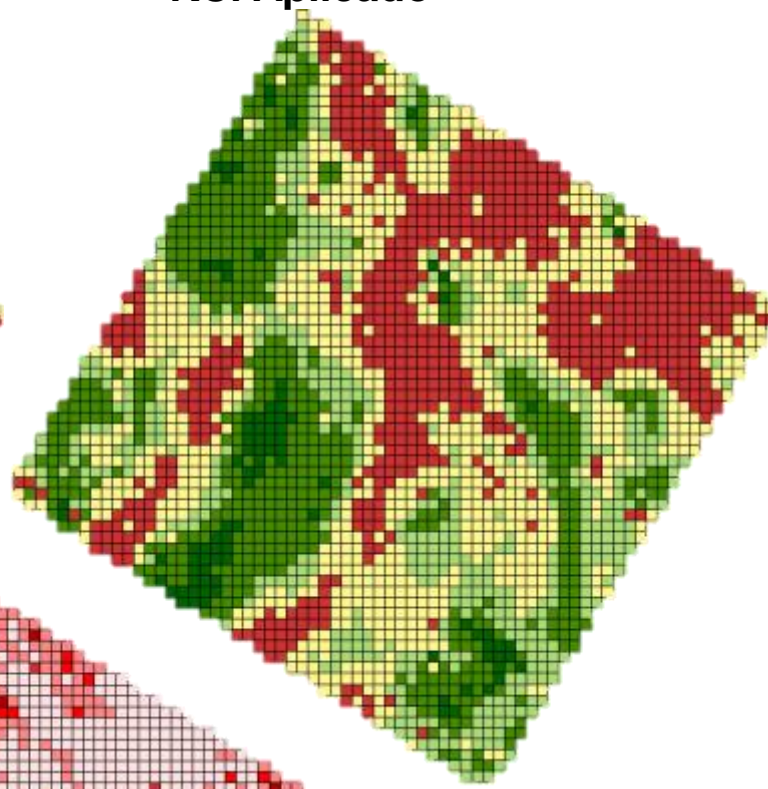
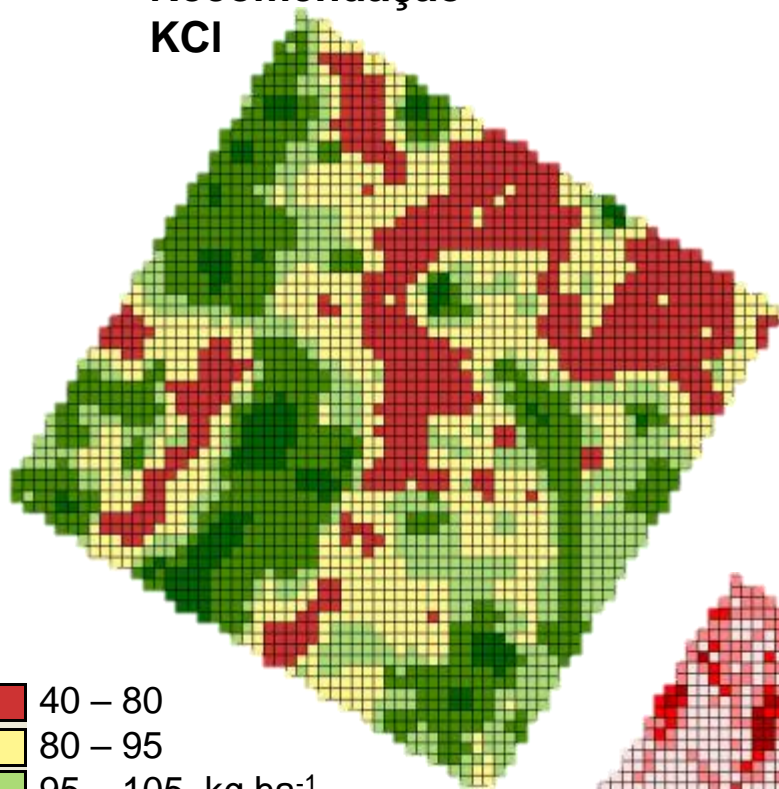
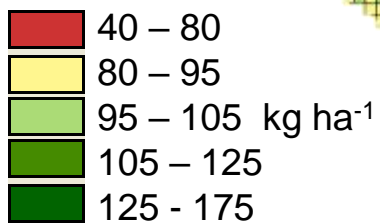

Erro de aplicação

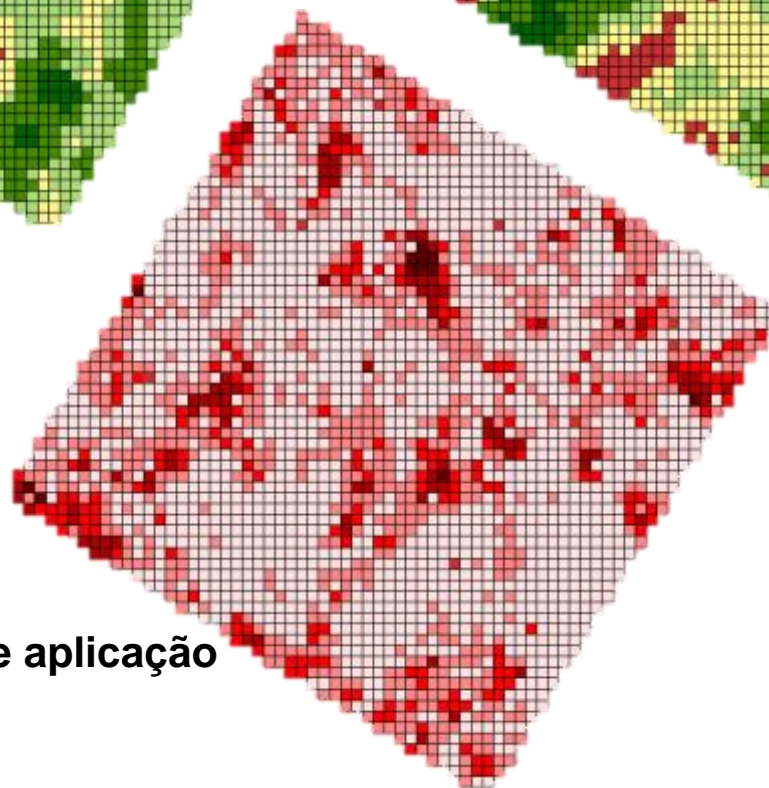
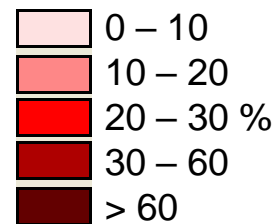

**Monitoramento
das aplicações**



Gesso e Calcário

Fósforo e Potássio



Agrishow, 2014



Prof. J. P. Molin

Semeadura em doses variadas

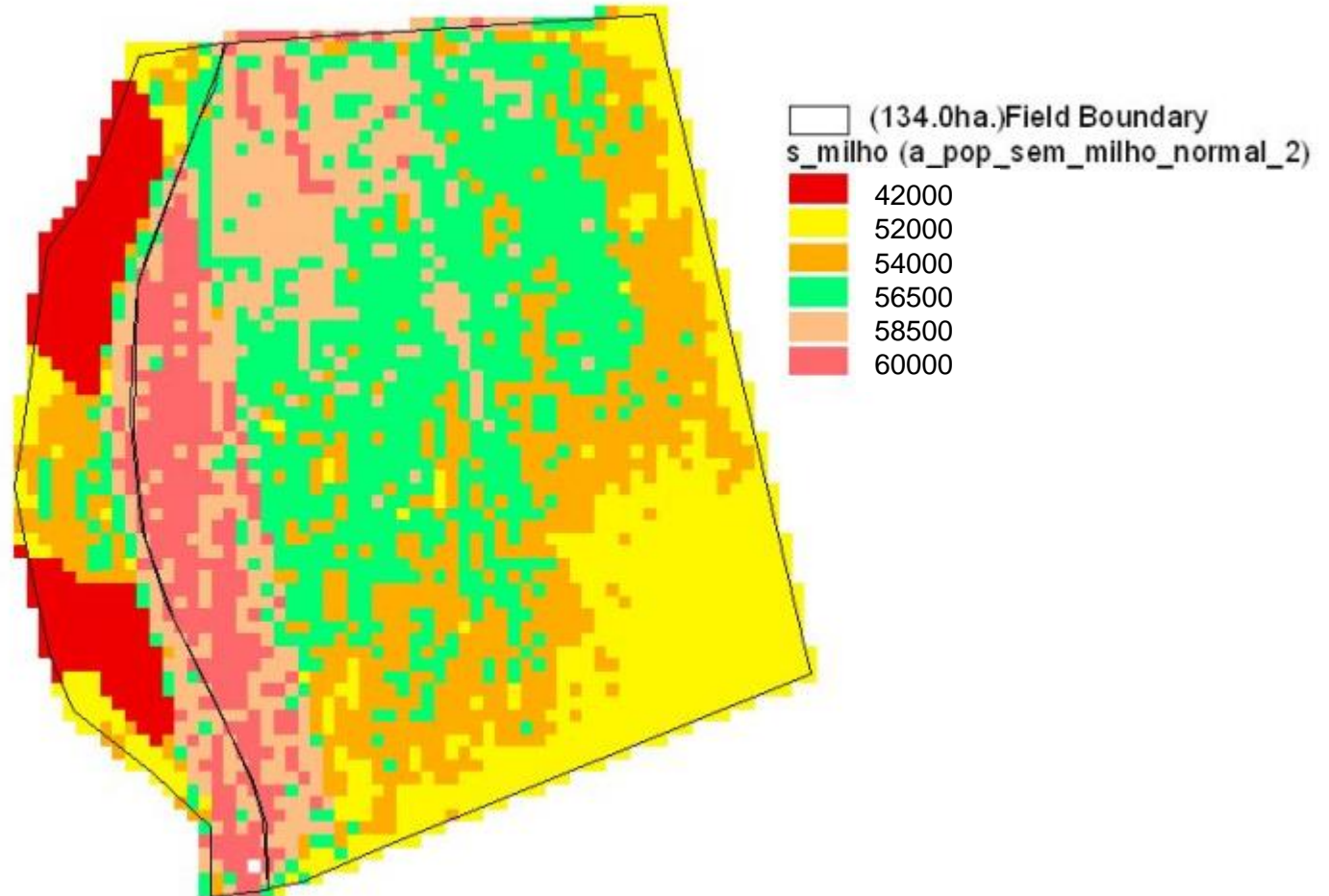



Sem transmissão!

Substituída por motor hidráulico



Controlado na cabine



Agrishow 2009



Layout de um sistema controlador de taxa variada com três canais: sementes, fertilizante A e fertilizante B

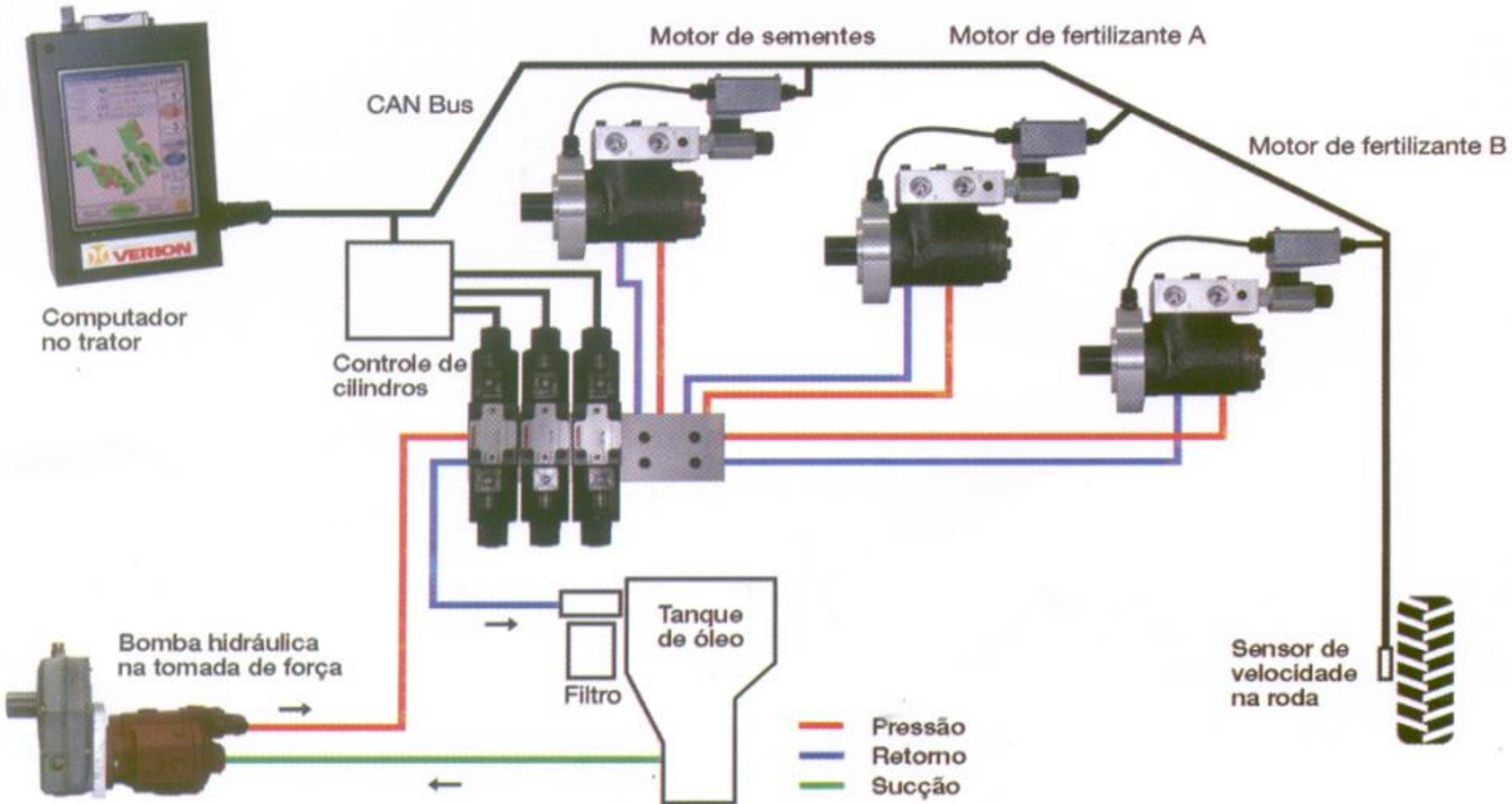



Precision Planting vSet

Integrated dual electric drive meters.

0.5 to 0.63 T/ha
(US \$22 / ha)

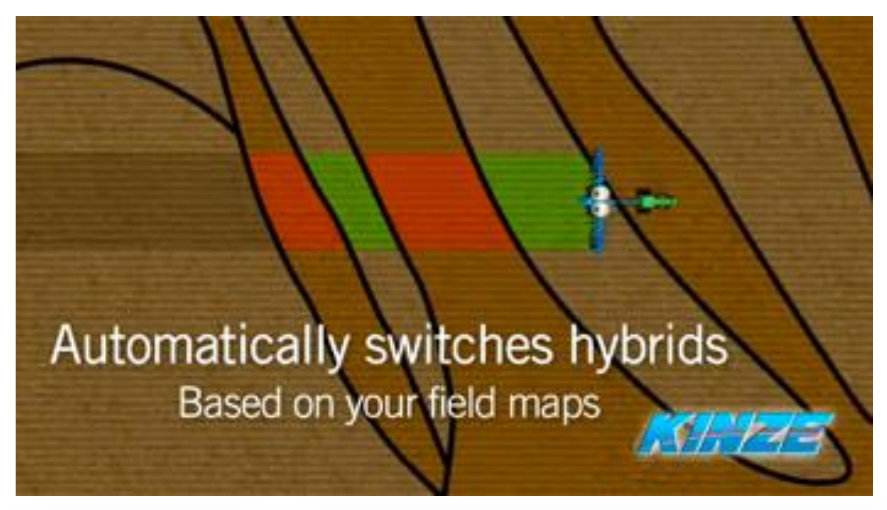

Sistema que controla automaticamente a abertura e fechamento da pulverização, plantio ou aplicação de fertilizantes, evitando desperdício ou falhas



Sistema que controla automaticamente a abertura e fechamento da pulverização, plantio ou aplicação de fertilizantes, evitando desperdício ou falhas

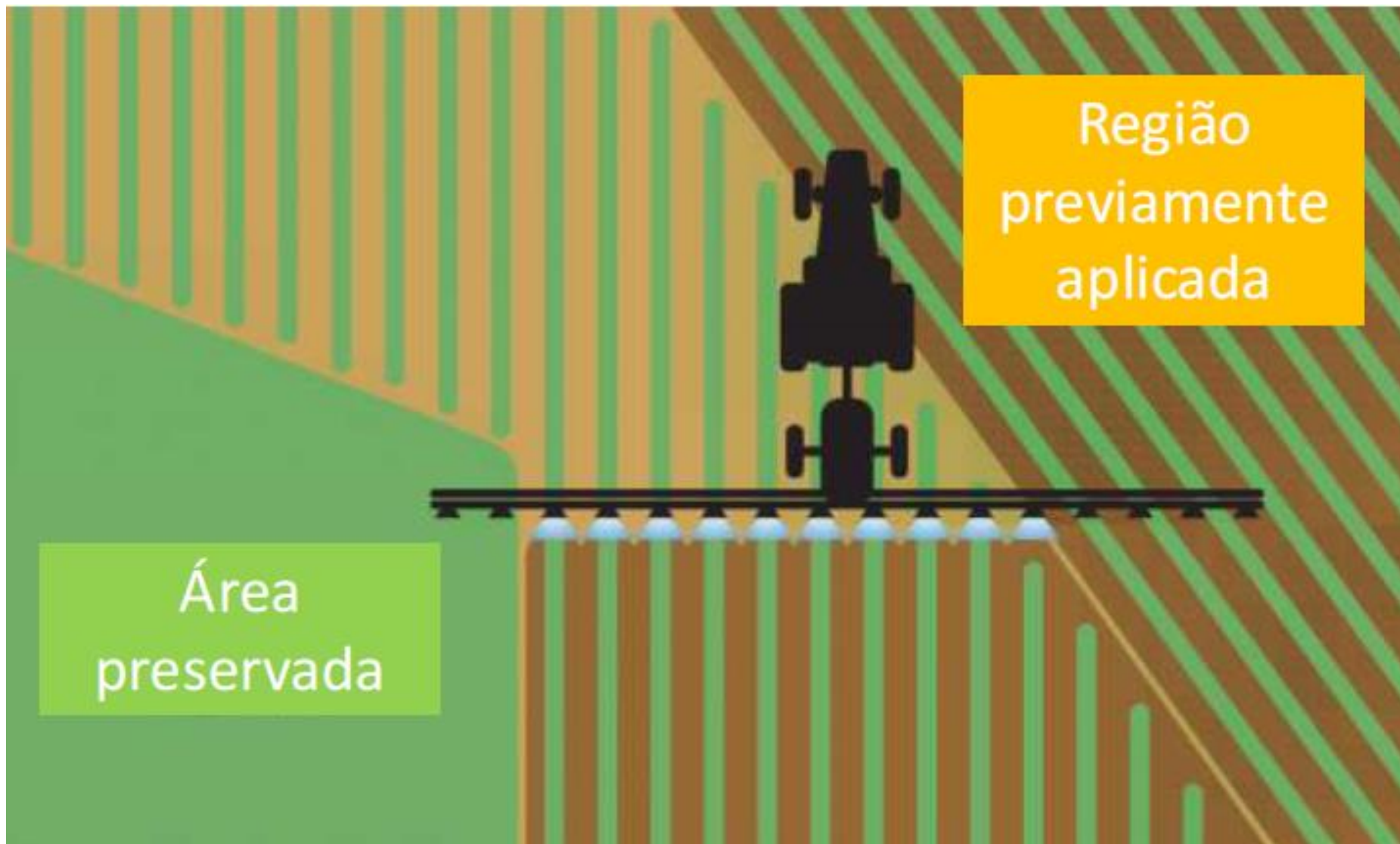



Preparo localizado do solo - Escarificador de movimento vertical



Amazone Centaur

WERNER, A. (2008)

Taxa variável na irrigação

Irrigação de Precisão

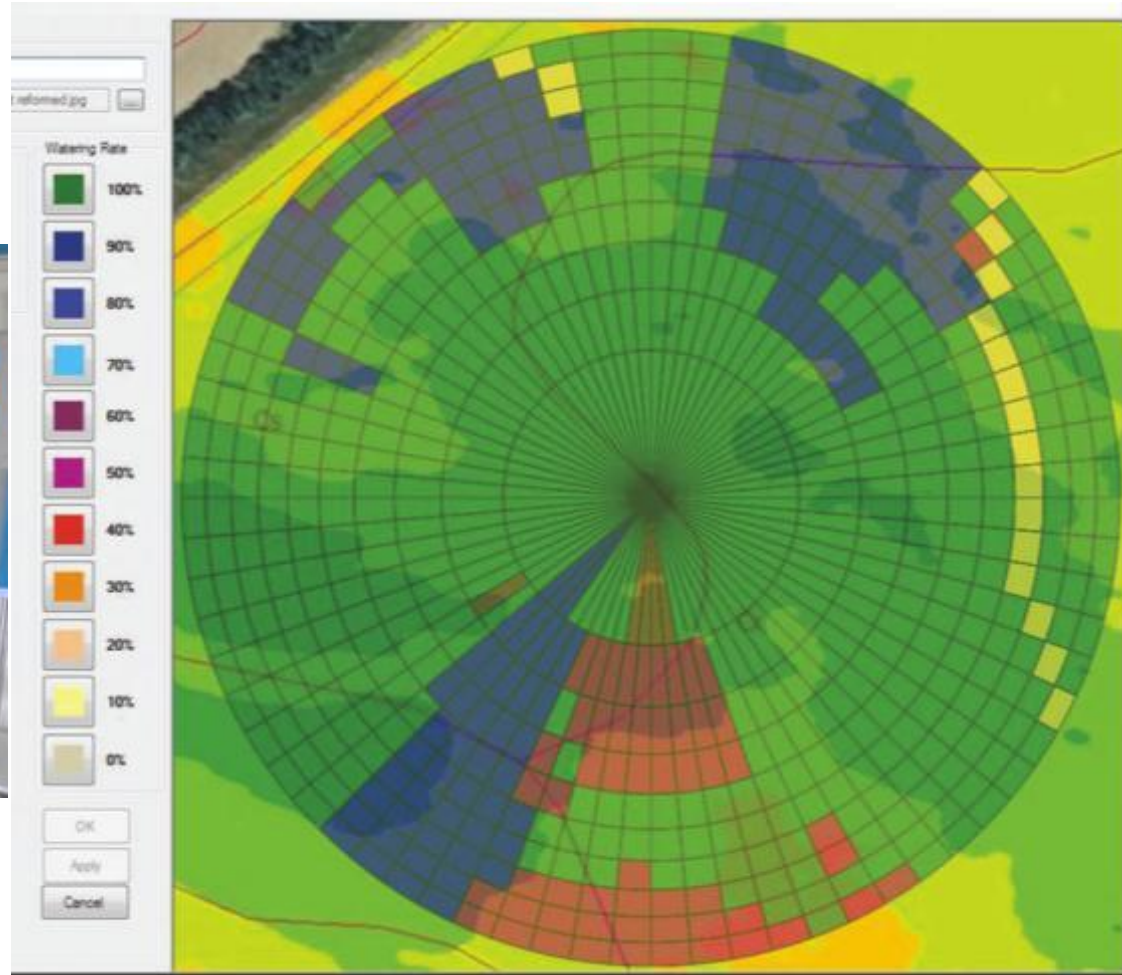



Taxa variável na pulverização



Pulverização variável



Aplicação de agroquímicos: situações e opções

- Aplicar calda em volume variável
- Aplicar princípio ativo em volume variável
- Aplicar ou não aplicar

Aplicar calda em volume variável

Variação de volume de calda por meio combinação de número e vazões de bicos

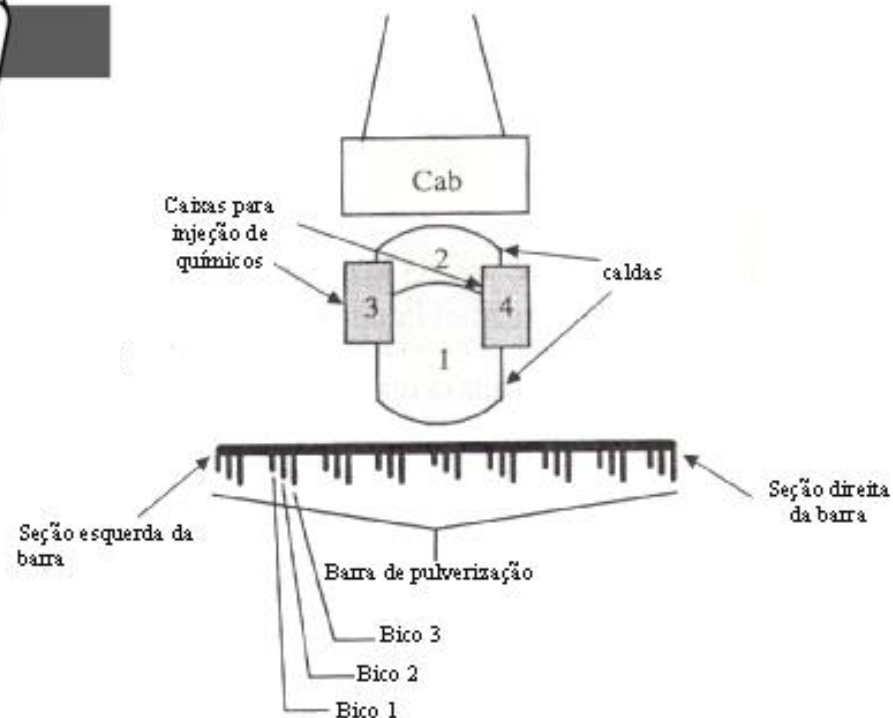
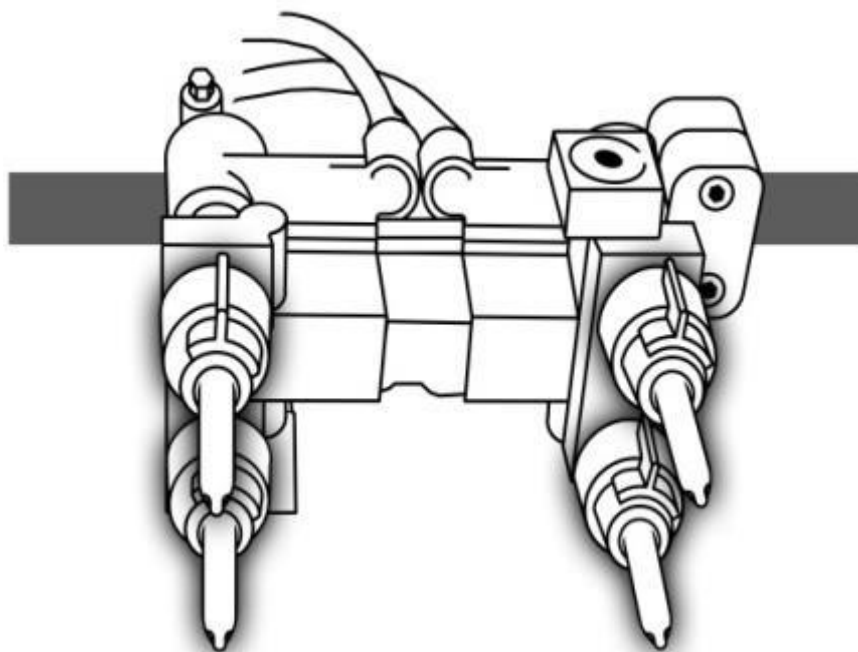

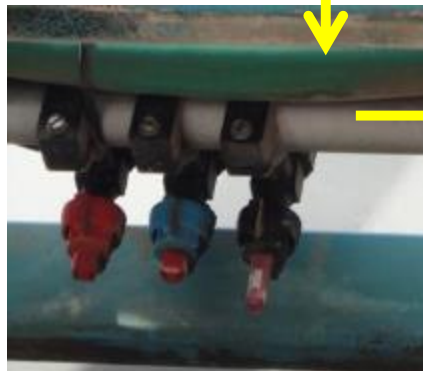
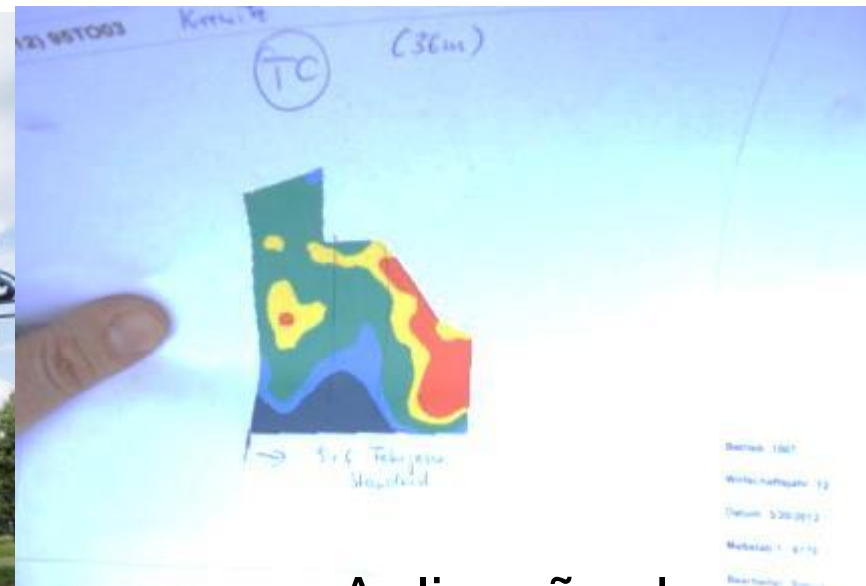

Aplicação de fungicida em taxas variáveis em função da biomassa estimada por imagens de satélite (Alemanha, 2012)



Aplicar princípio ativo em volume variável

Variação de doses de princípio ativo com injeção na tubulação de água

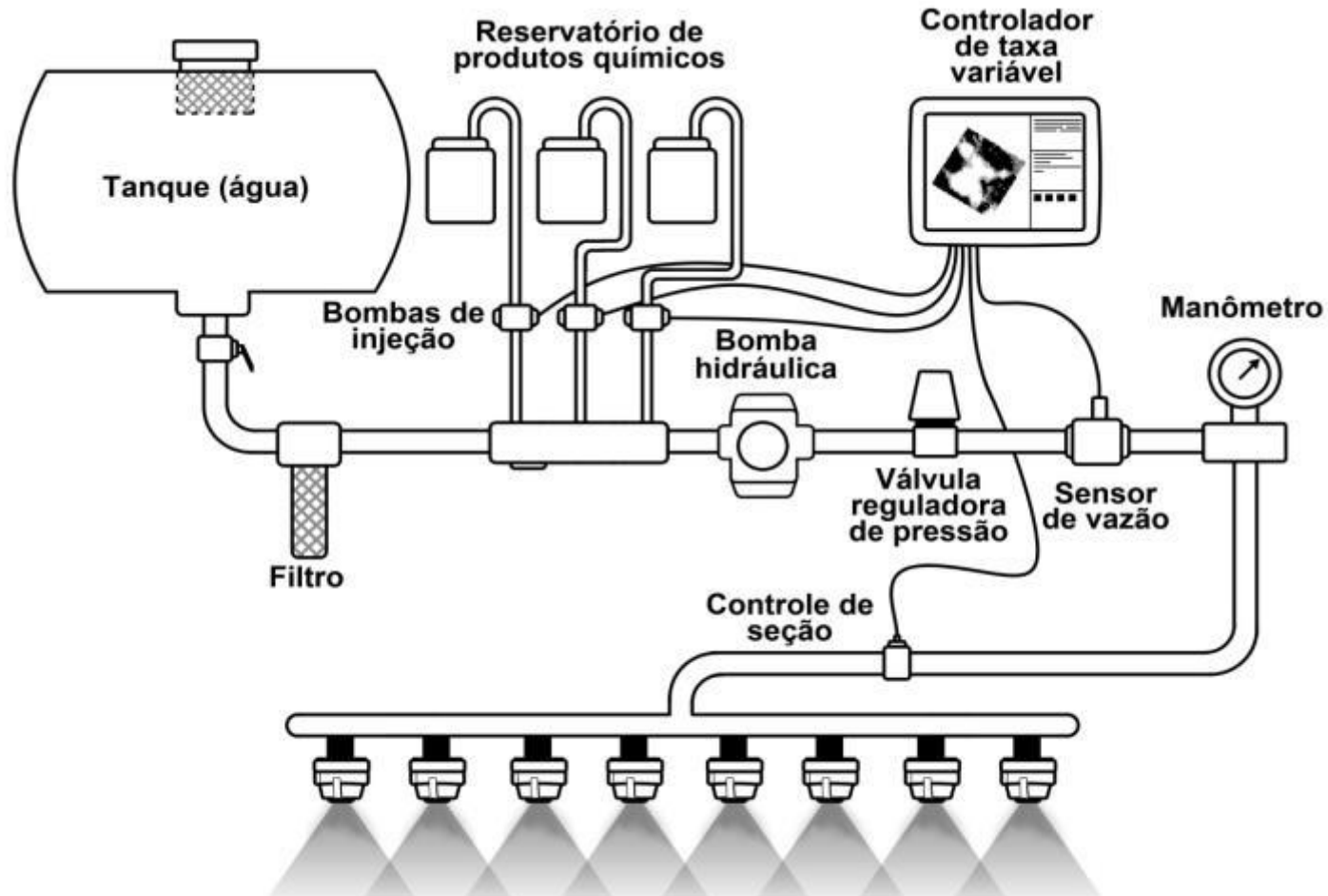

Aplicar ou não aplicar





Folheto Herbicat



Uma forma de se aprofundar no tema:

LEB 447 – Agricultura de Precisão
(optativa)