

# LER 332 - Mecânica e Máquinas Motoras

## 7ª Semana de Aula: **Motores de Combustão Interna III**

Prof.Dr. Casimiro Dias Gadanha Junior

### **1- Objetivos**

- Conhecer a constituição e o funcionamento do Sistema de Válvulas
- Conhecer a constituição e o funcionamento do Sistema de Alimentação de combustível e de ar
- Conhecer a constituição e o funcionamento do Sistema de Lubrificação
- Conhecer a constituição e o funcionamento do Sistema de Arrefecimento

### **2- Bibliografia**

MIALHE, L.G. **Máquinas motoras na agricultura** . São Paulo: EDUSP,1980.cap.10, p.213-282: Sistemas complementares dos motores do ciclo Diesel

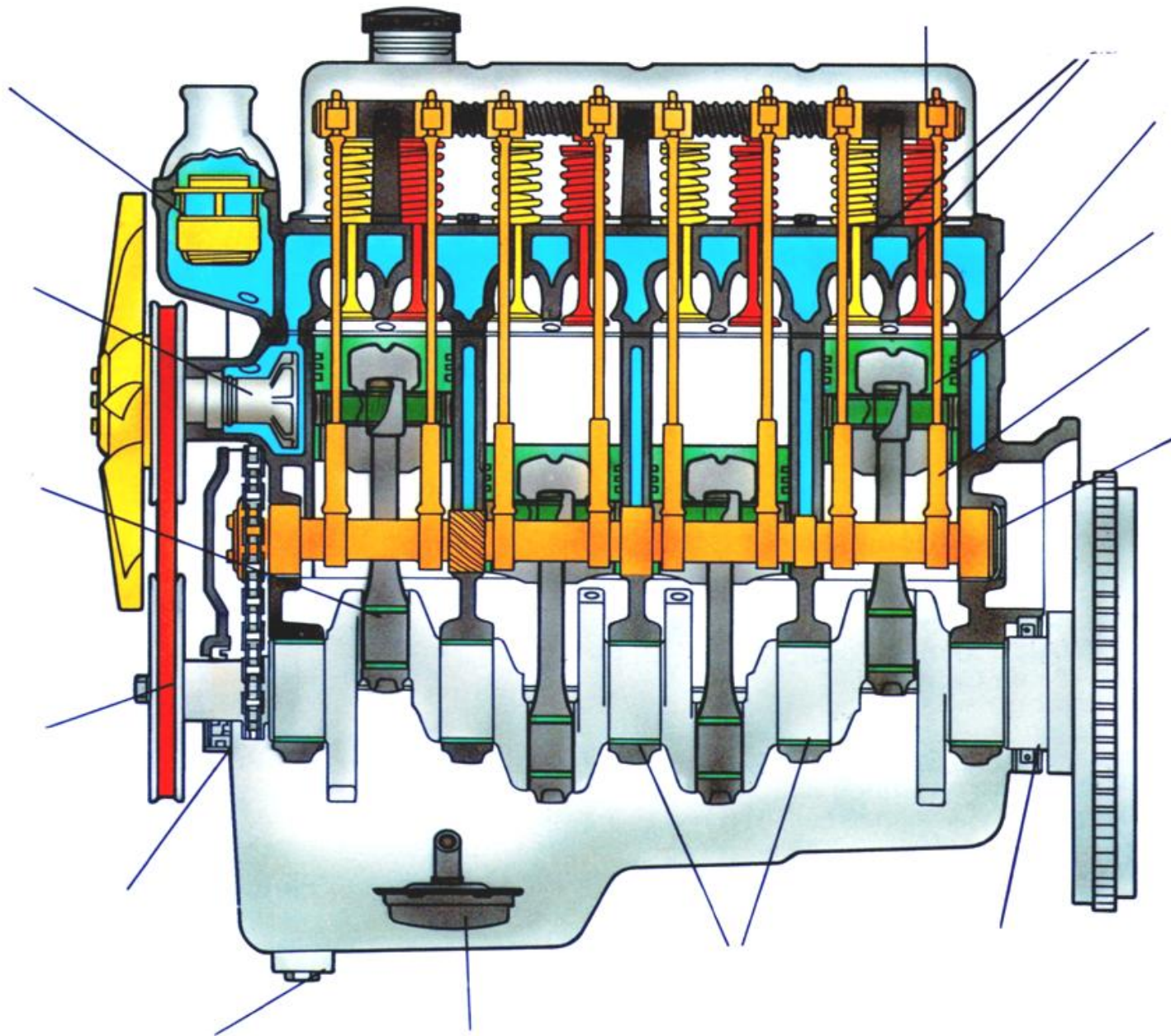

# **Sistema de Válvulas**



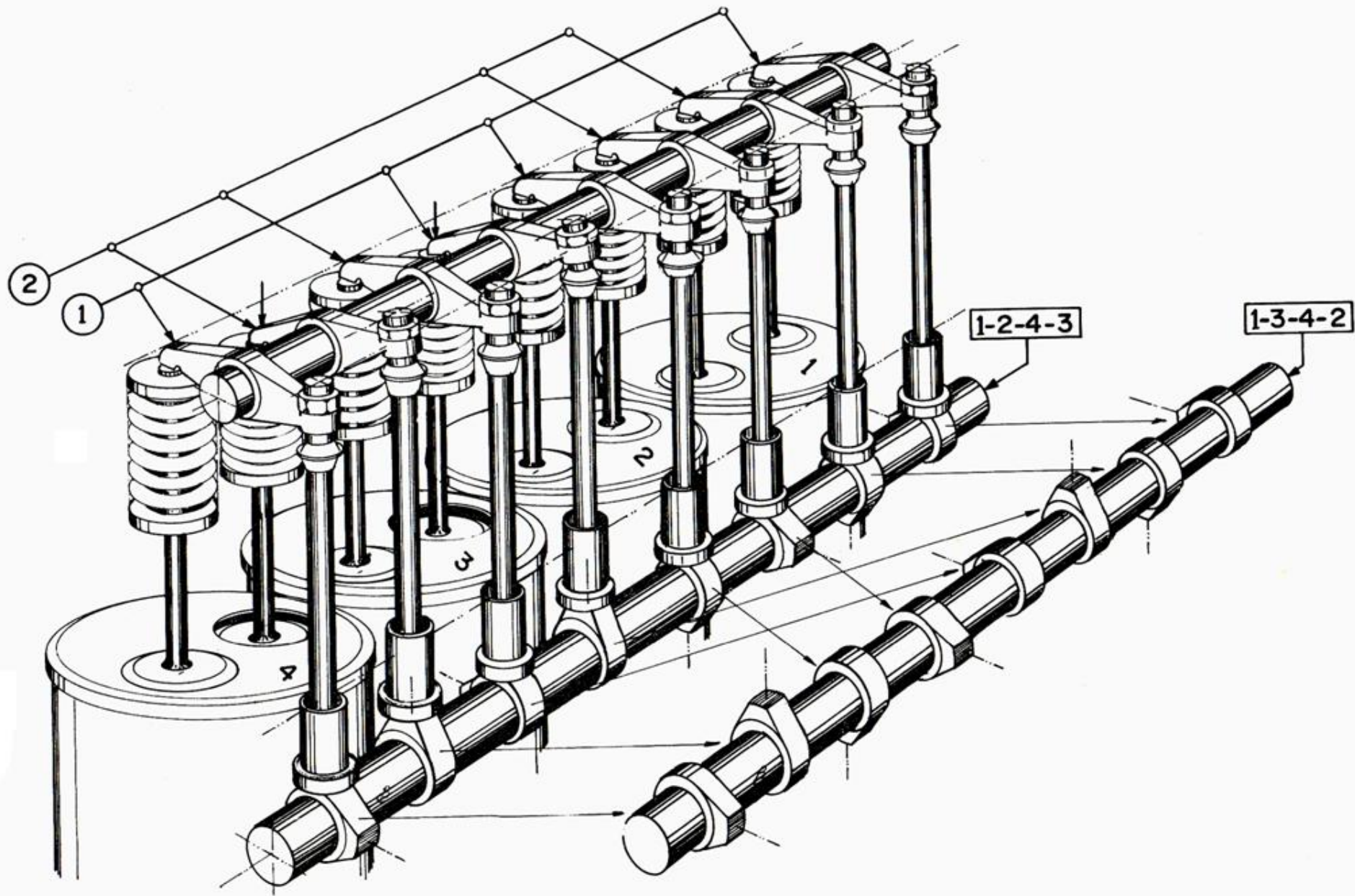

# INDIRETO

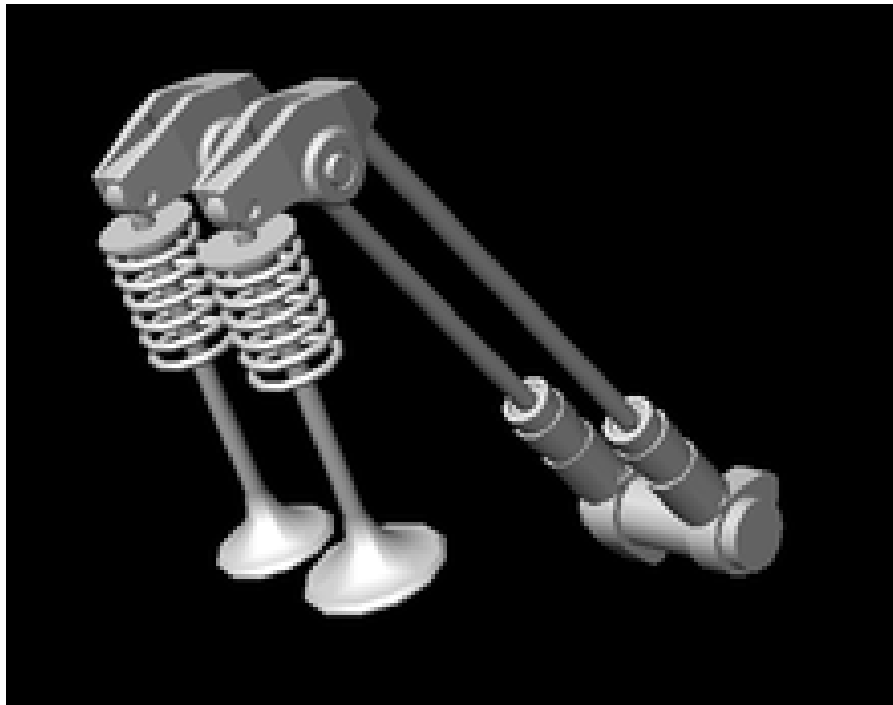

# DIRETO

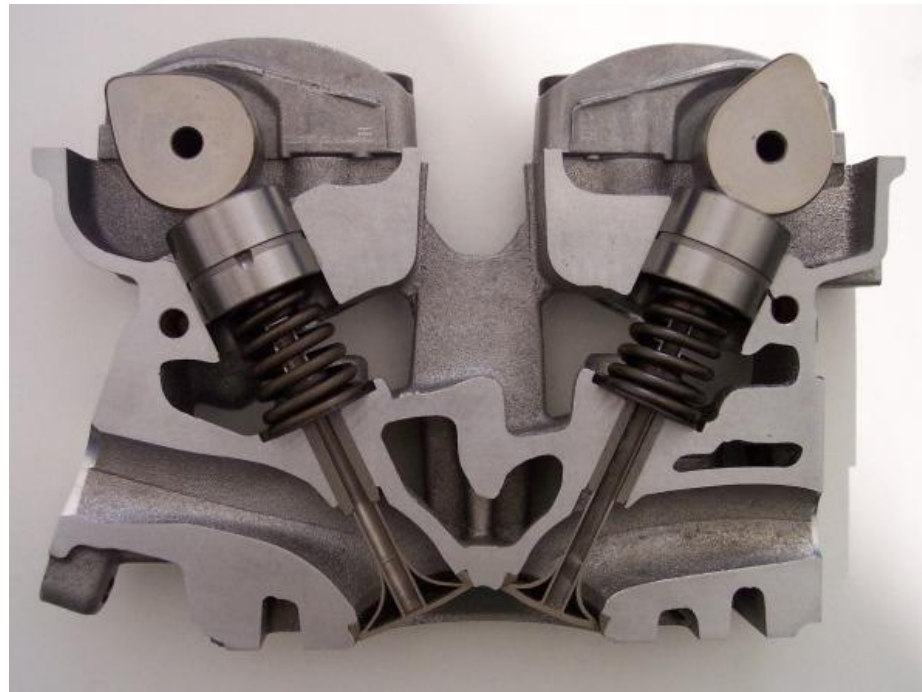

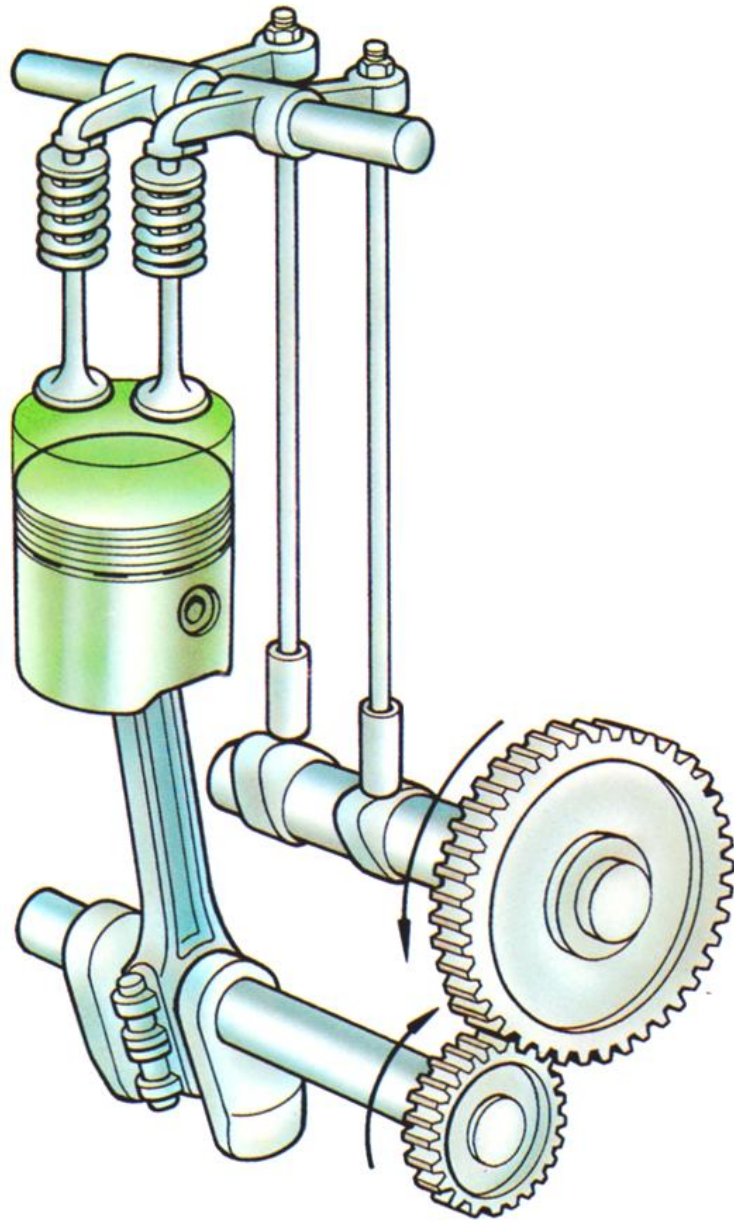

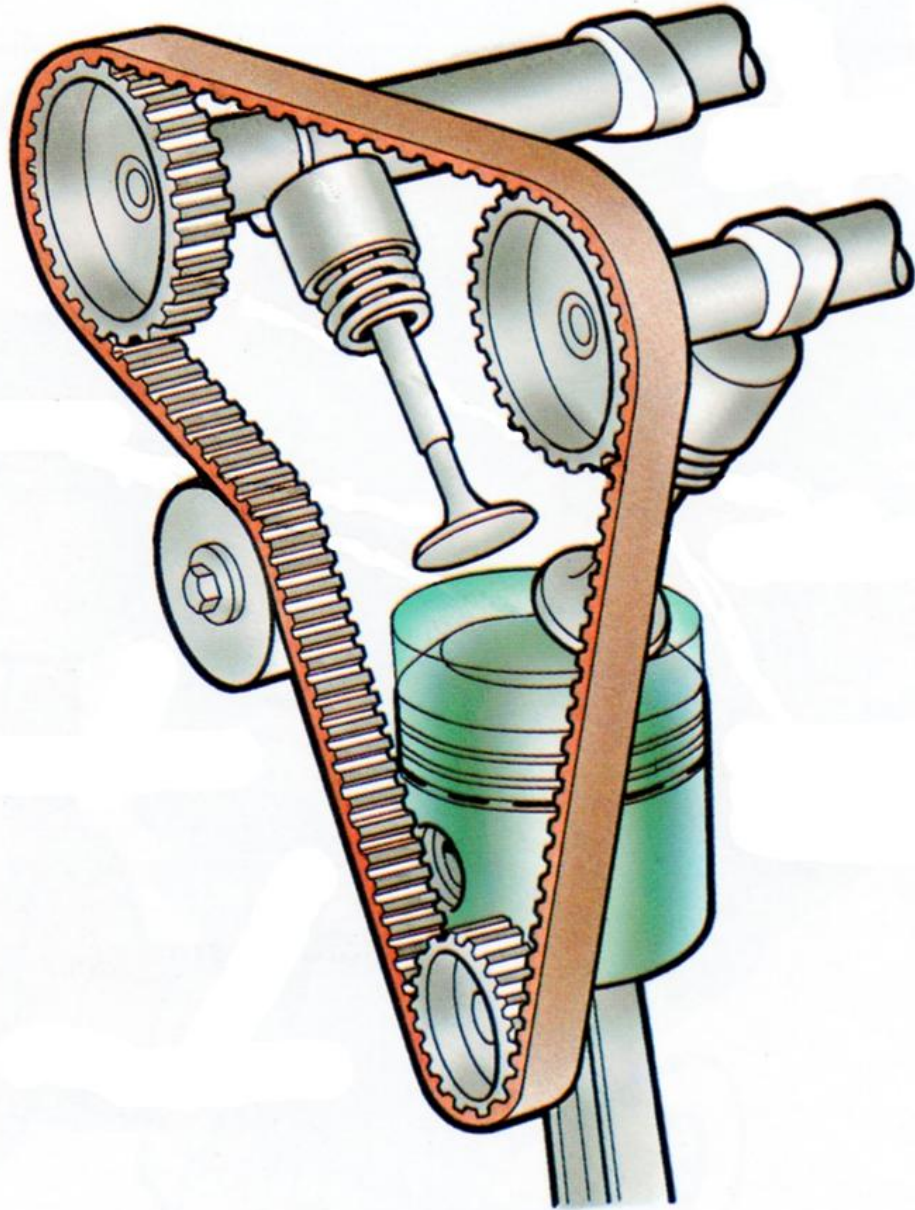



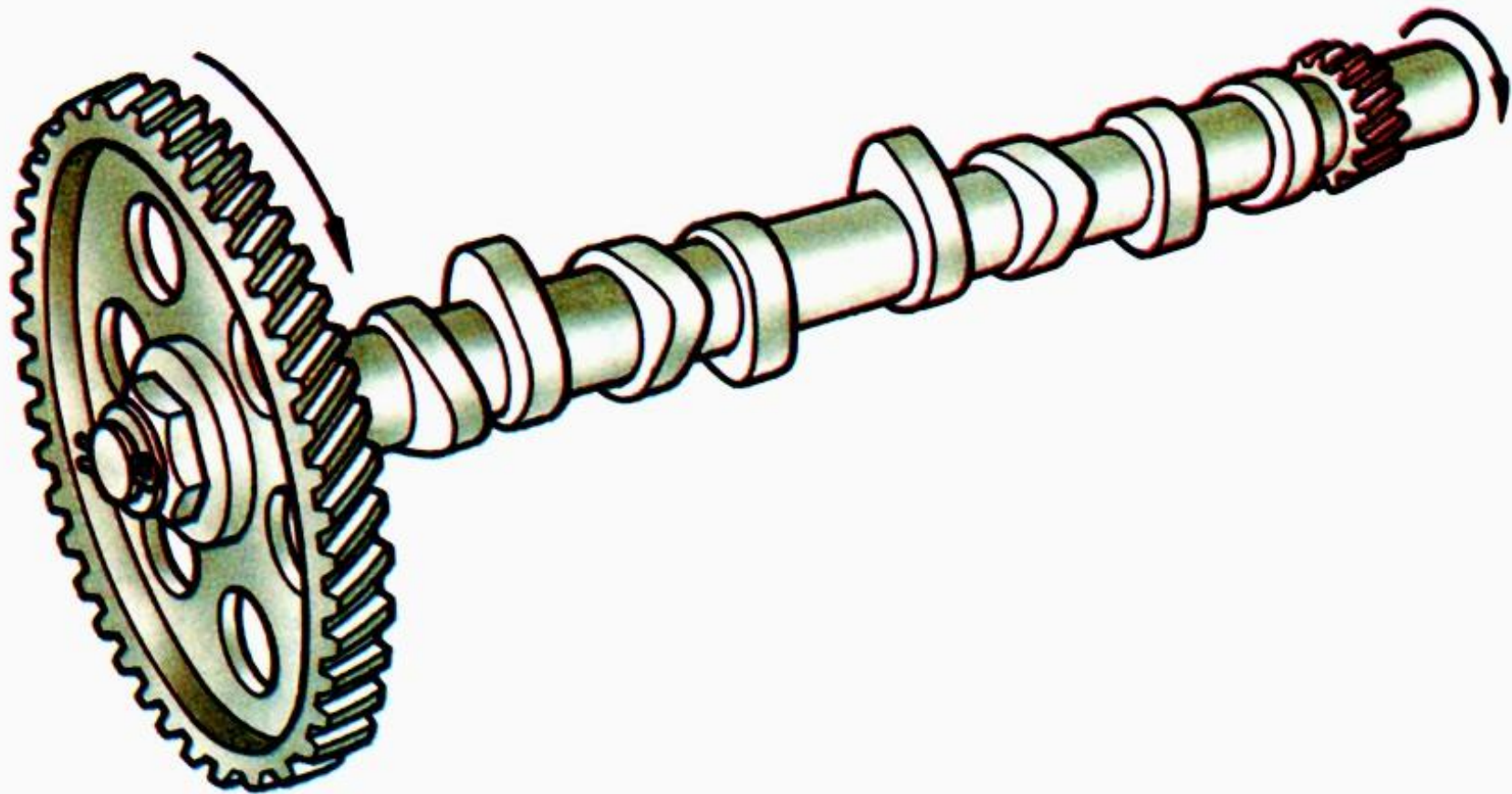

## Sistema de quatro válvulas

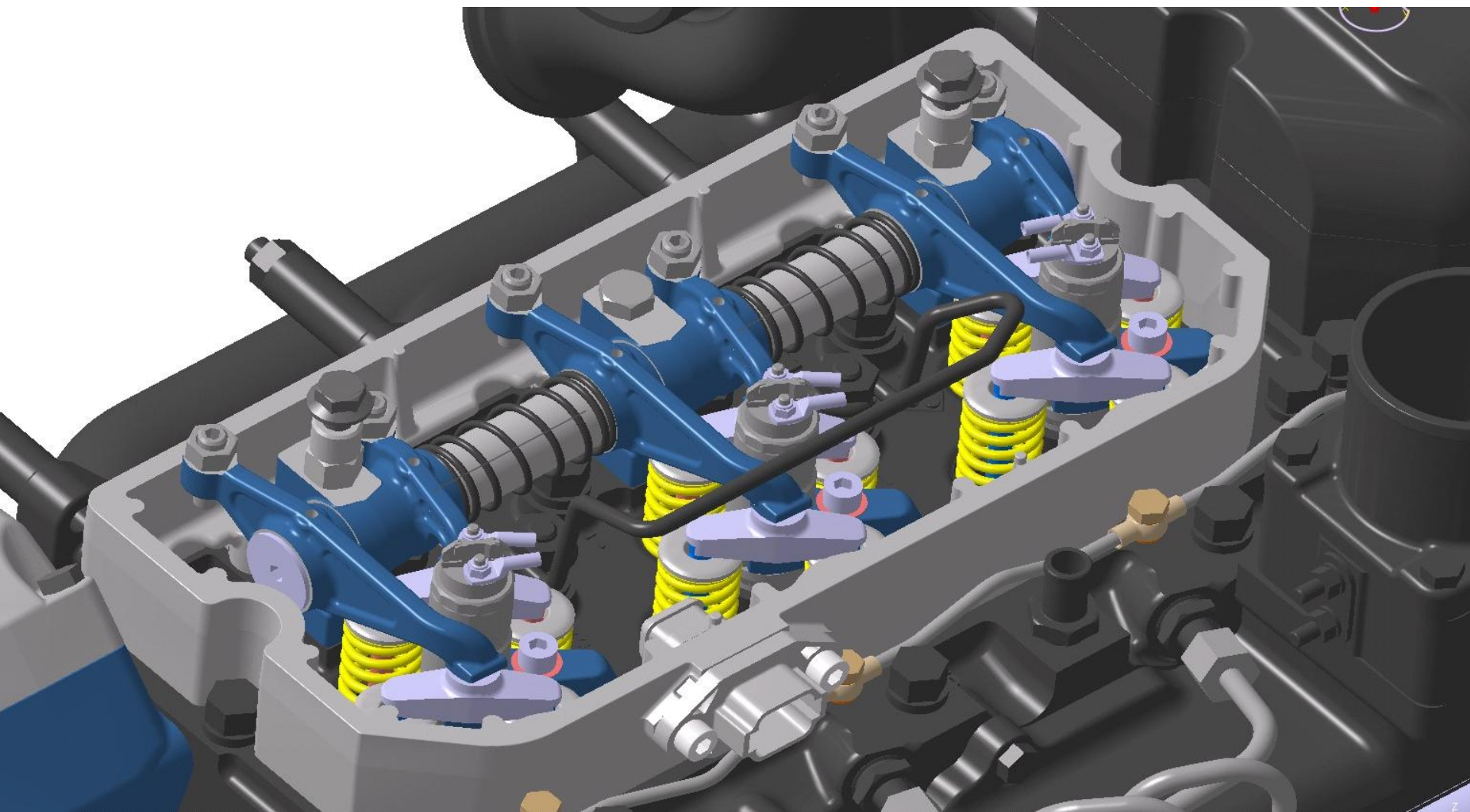

# **Sistema de Alimentação de combustível dos Motores de Combustão Interna de Ciclo Diesel**

# **FUNÇÕES DO SISTEMA**

- SUPRIR QUANTIDADE CORRETA DE COMBUSTÍVEL EM FUNÇÃO DA ROTAÇÃO DO MOTOR E CARGA APLICADA**
- FAZER COMBUSTÍVEL ATINGIR CÂMARA DE COMBUSTÃO ATOMIZADO**
- PERMITIR INJEÇÃO NO MOMENTO EXATO DO CICLO.**



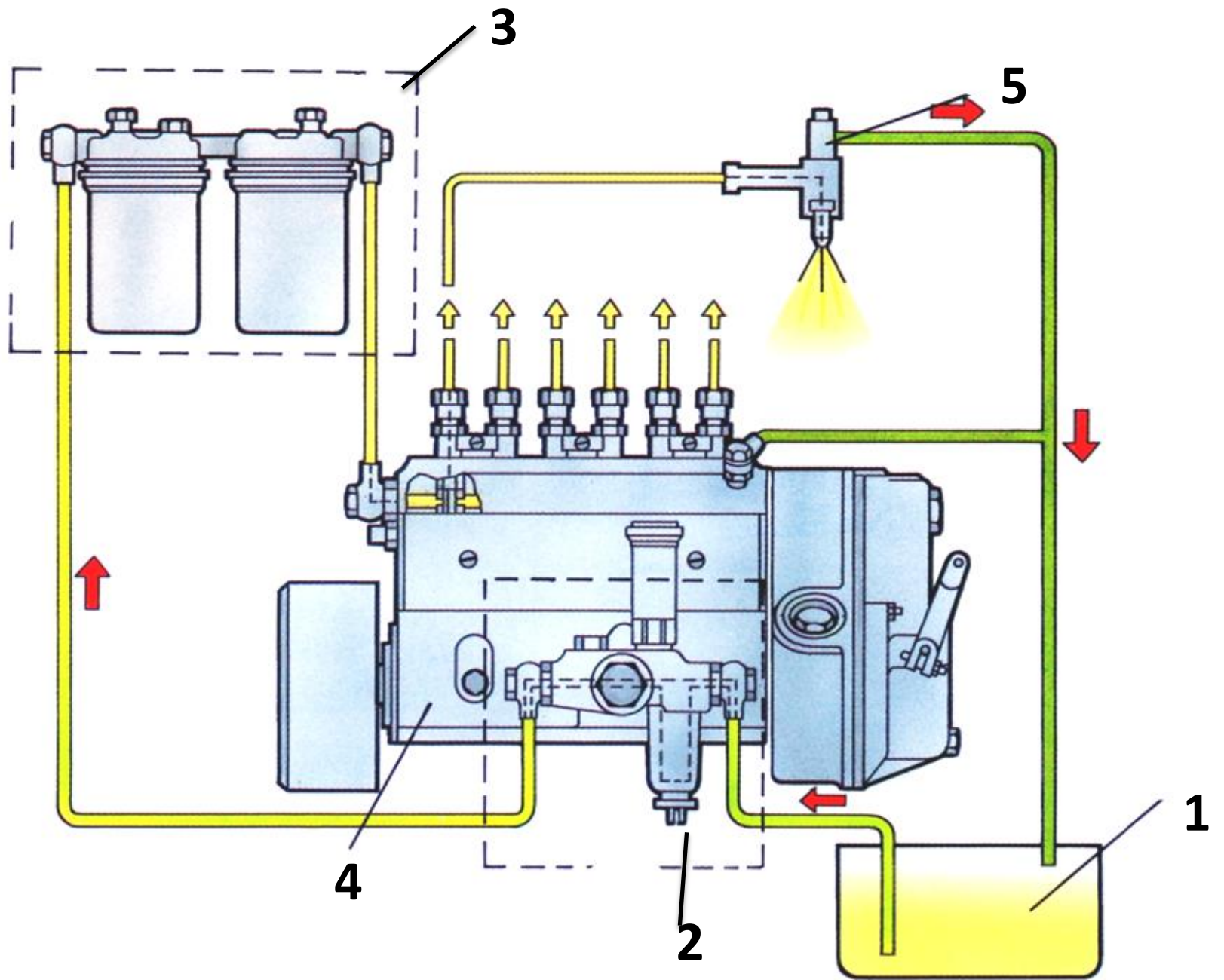

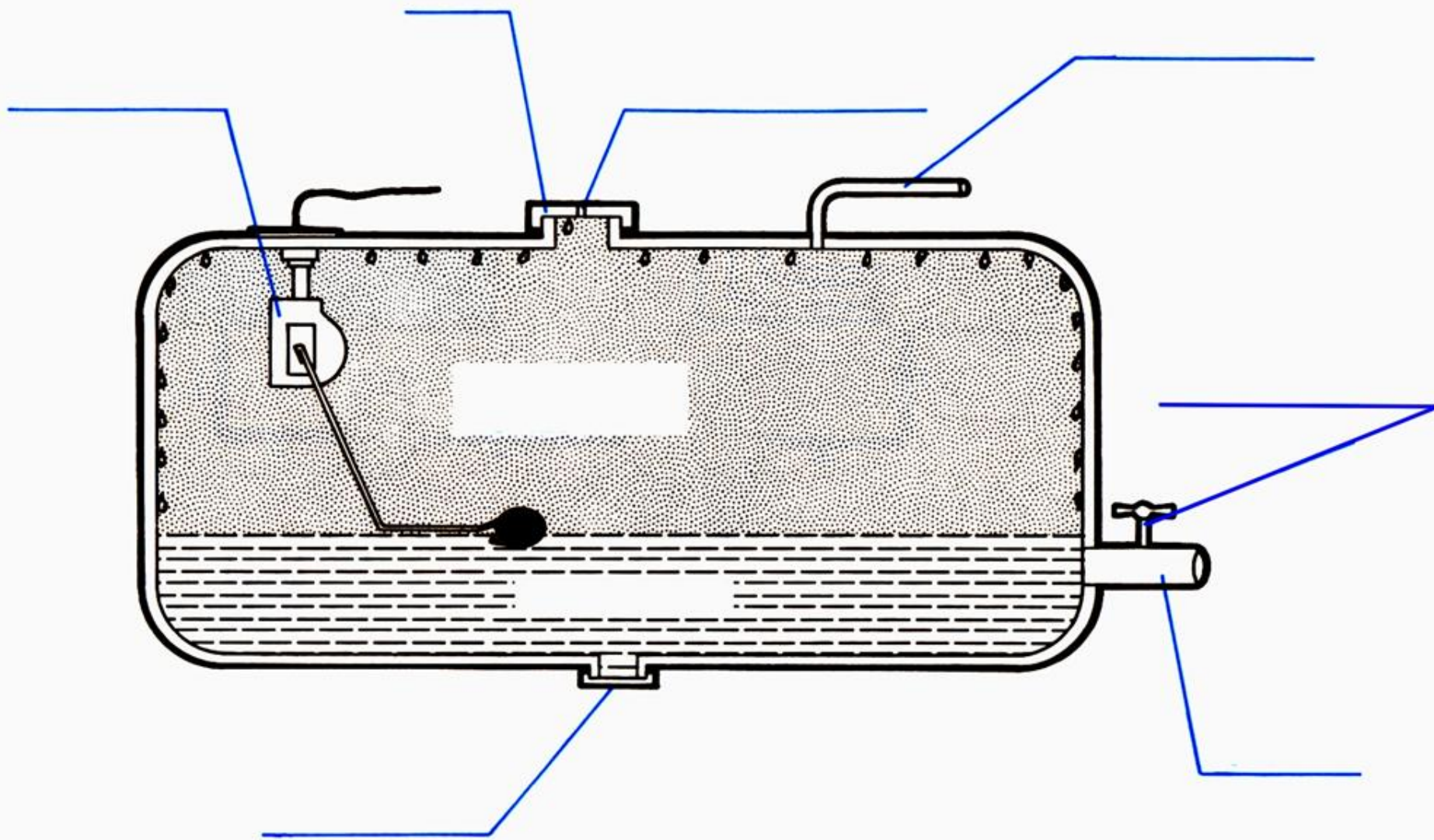

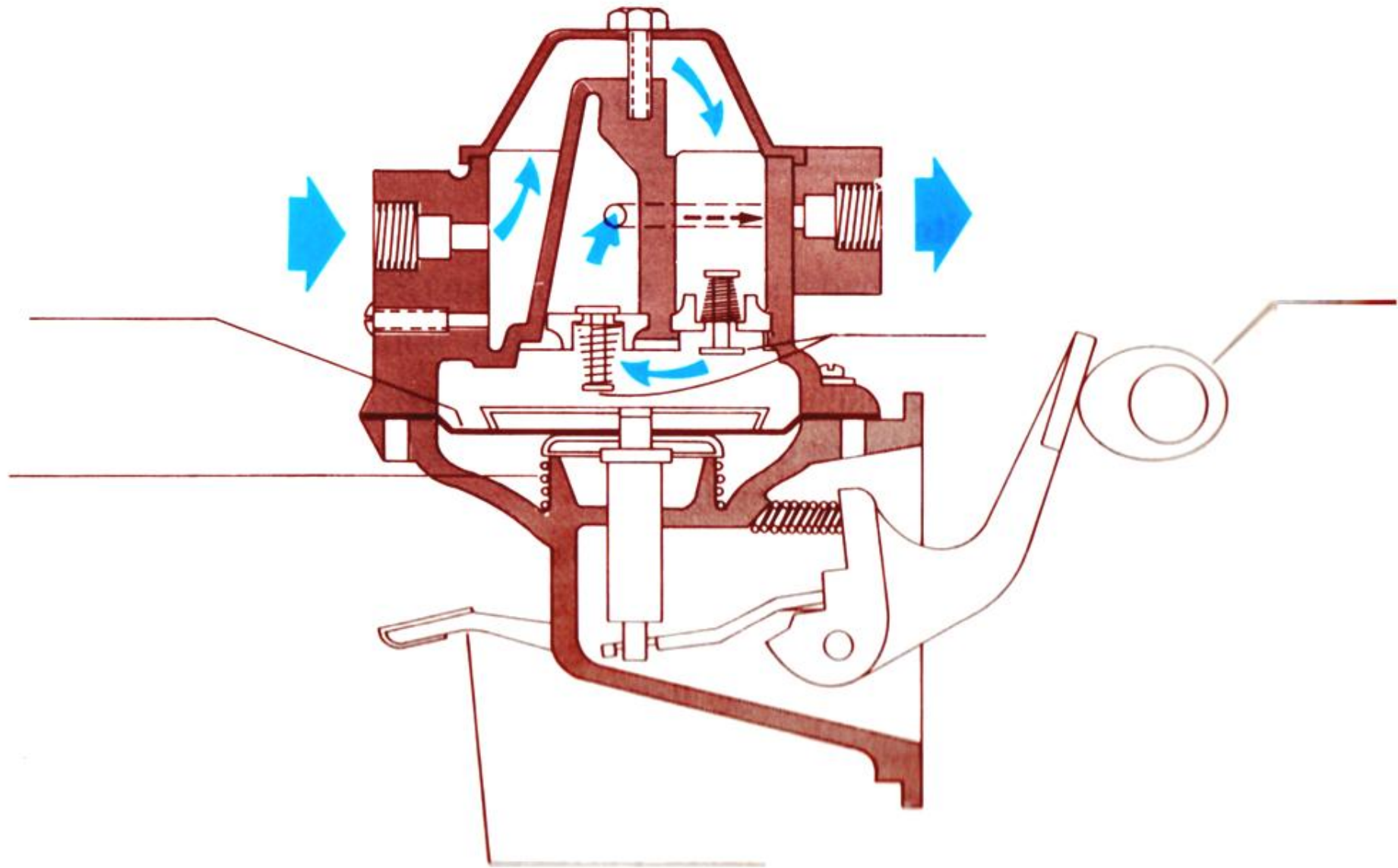

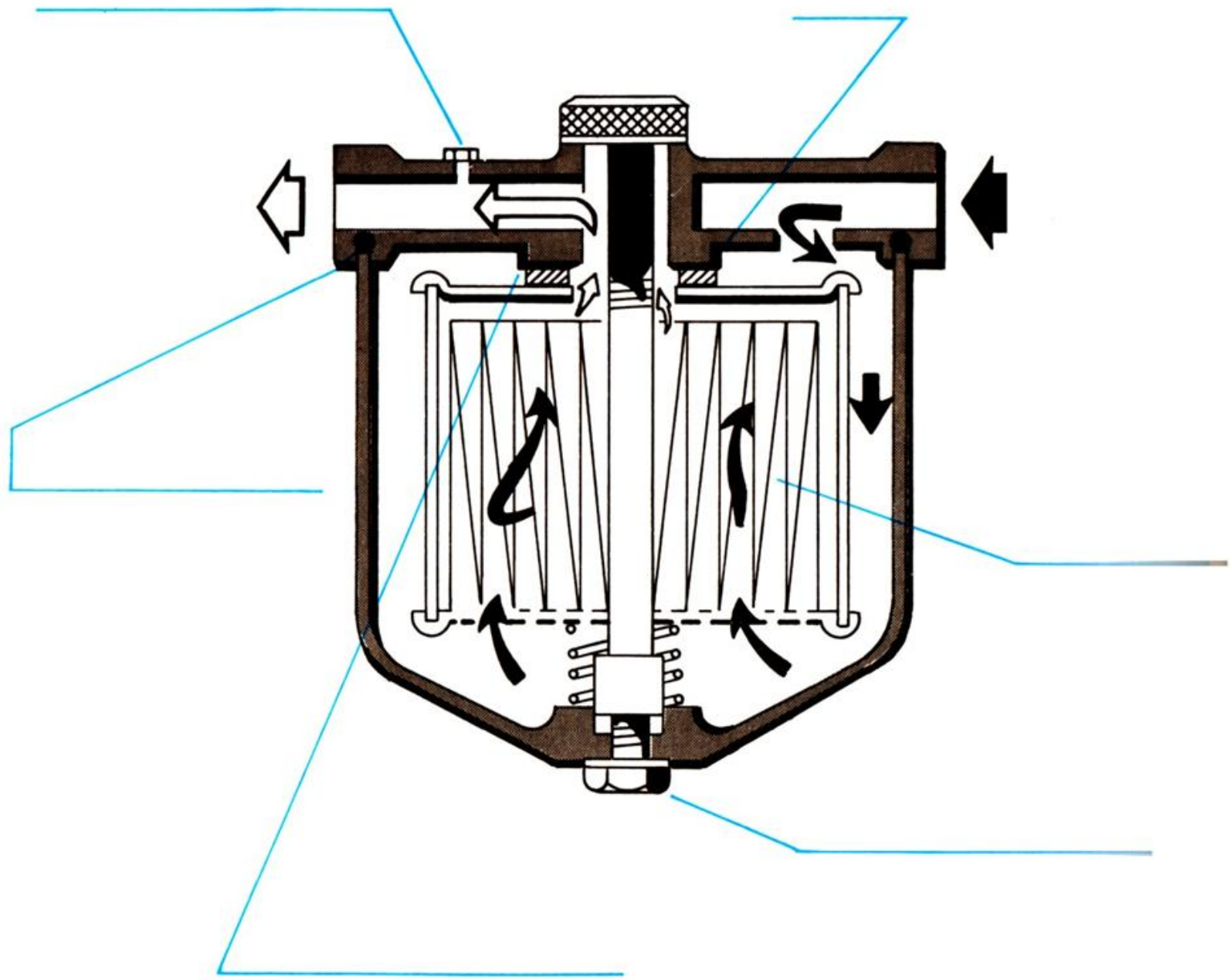



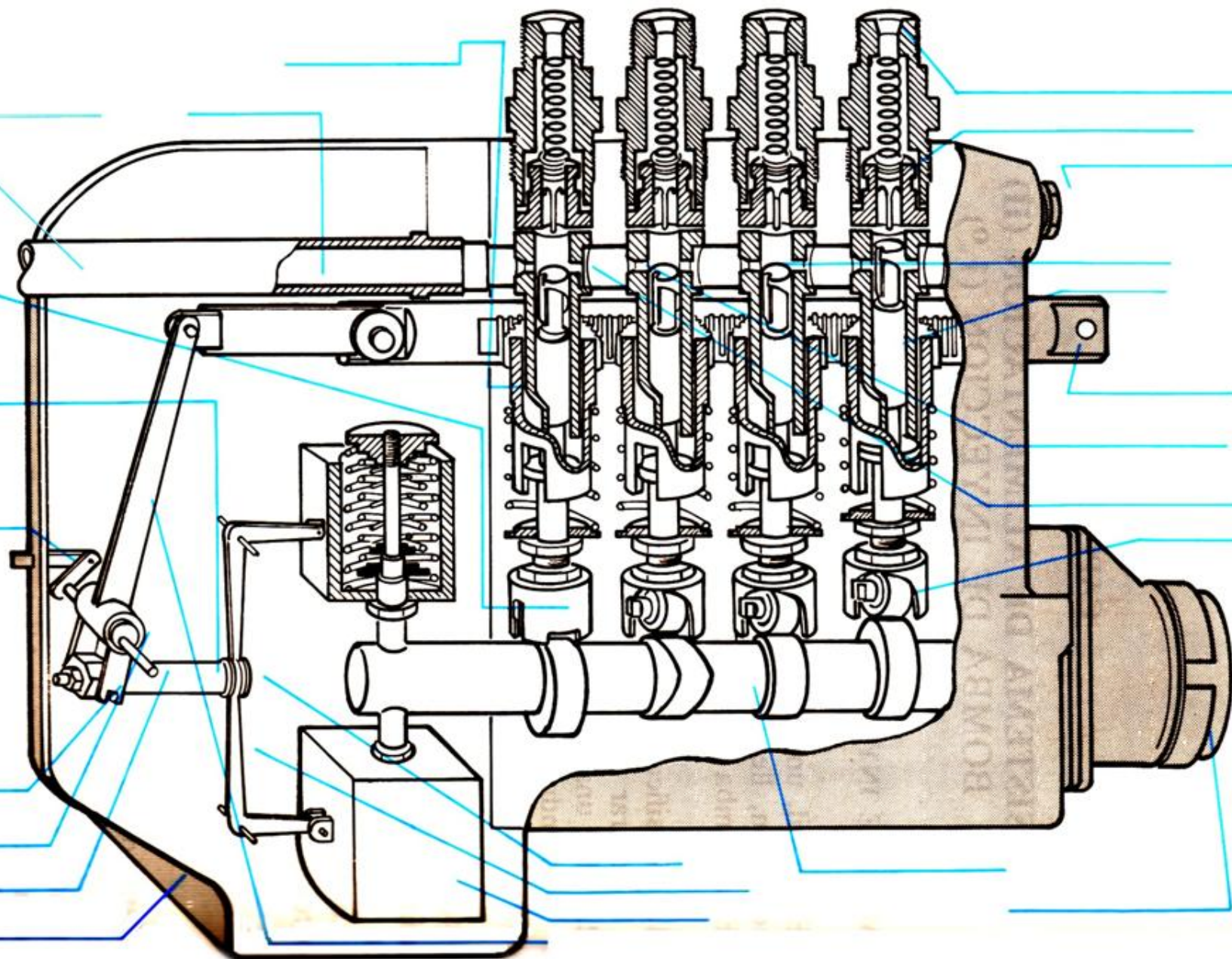

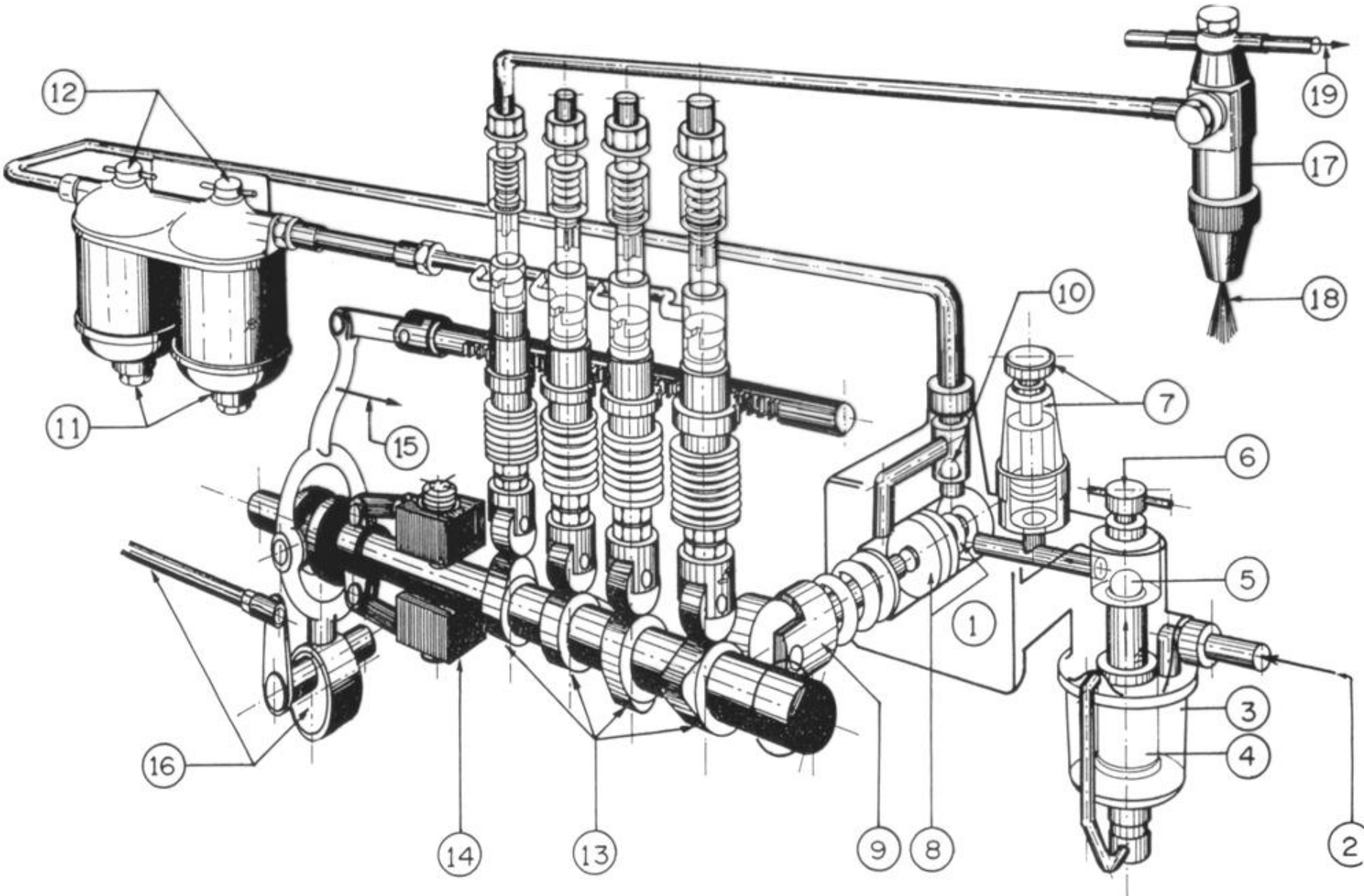

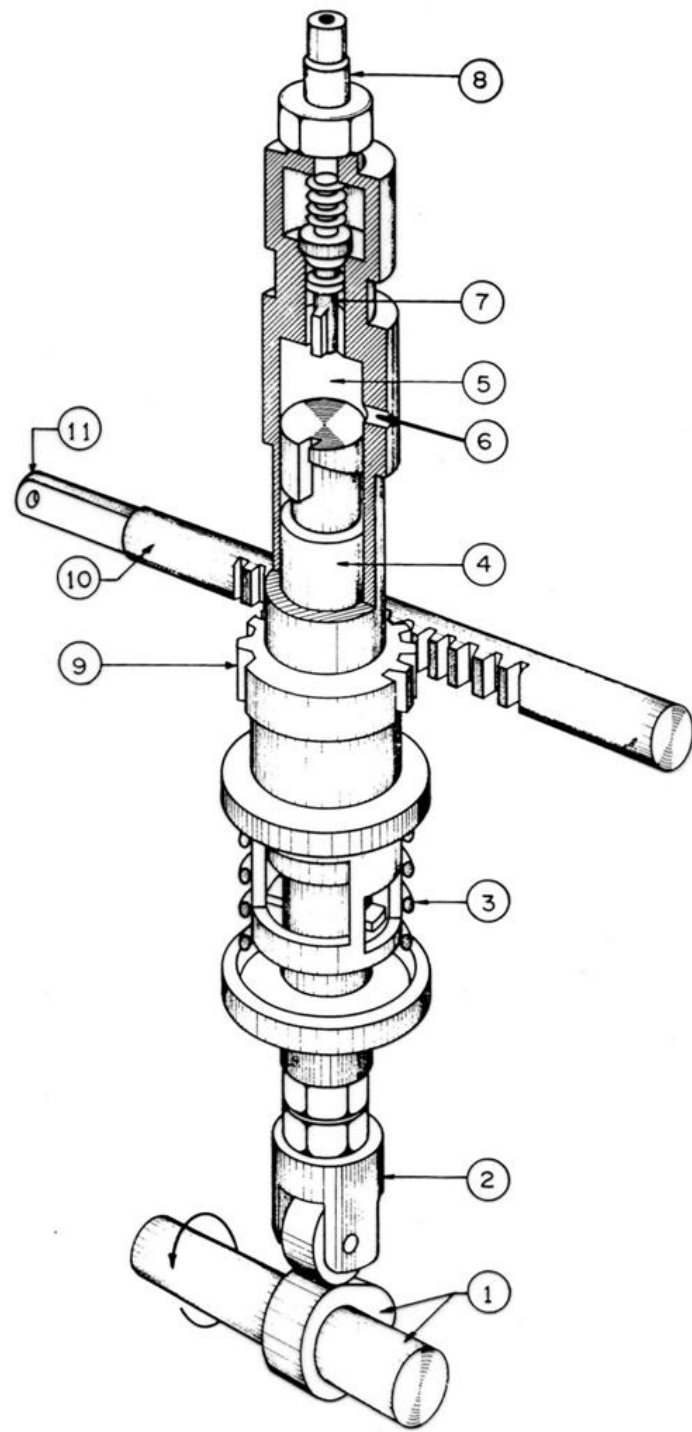



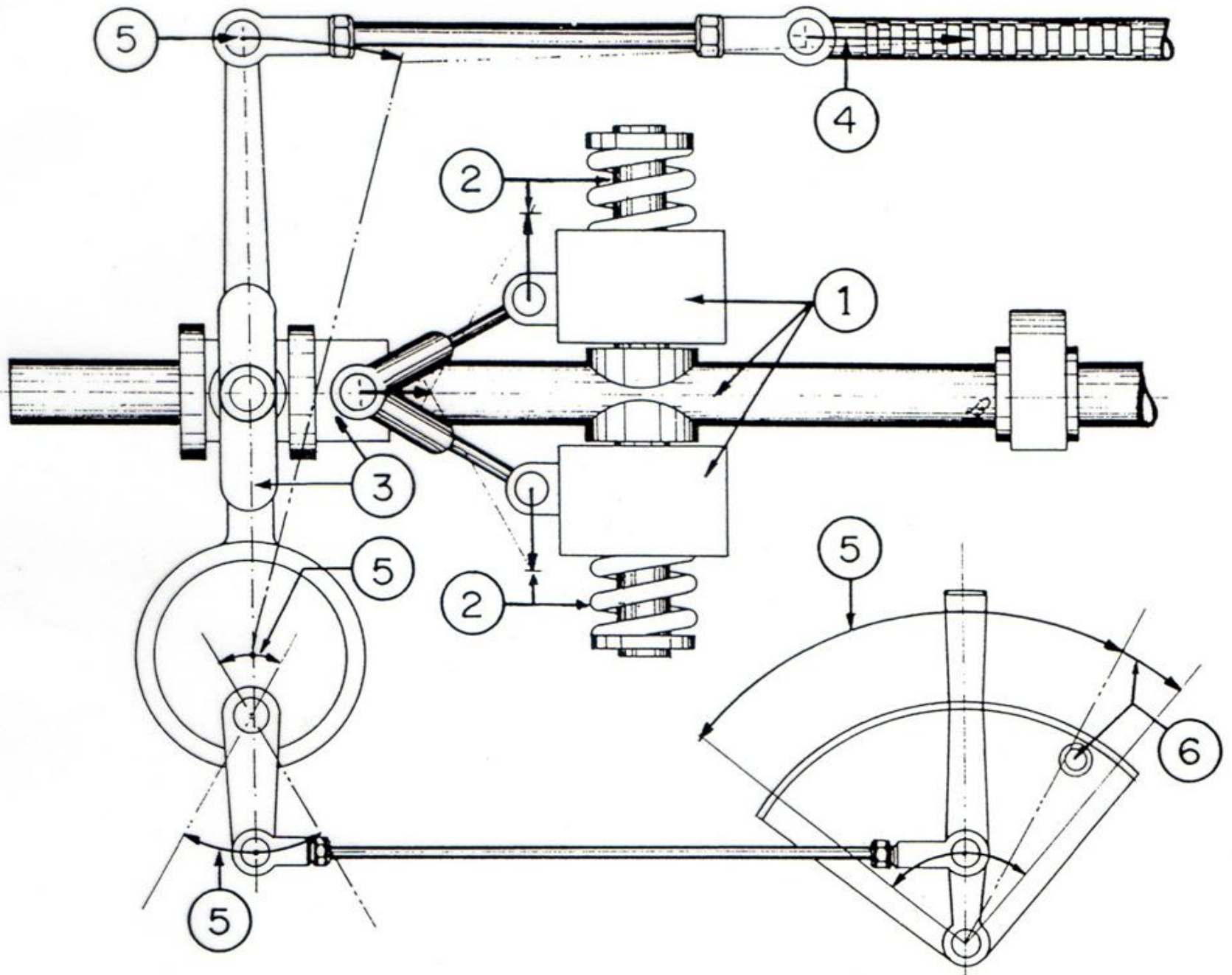



**A quantidade de combustível injetada sendo função da posição da alavanca do acelerador manual**

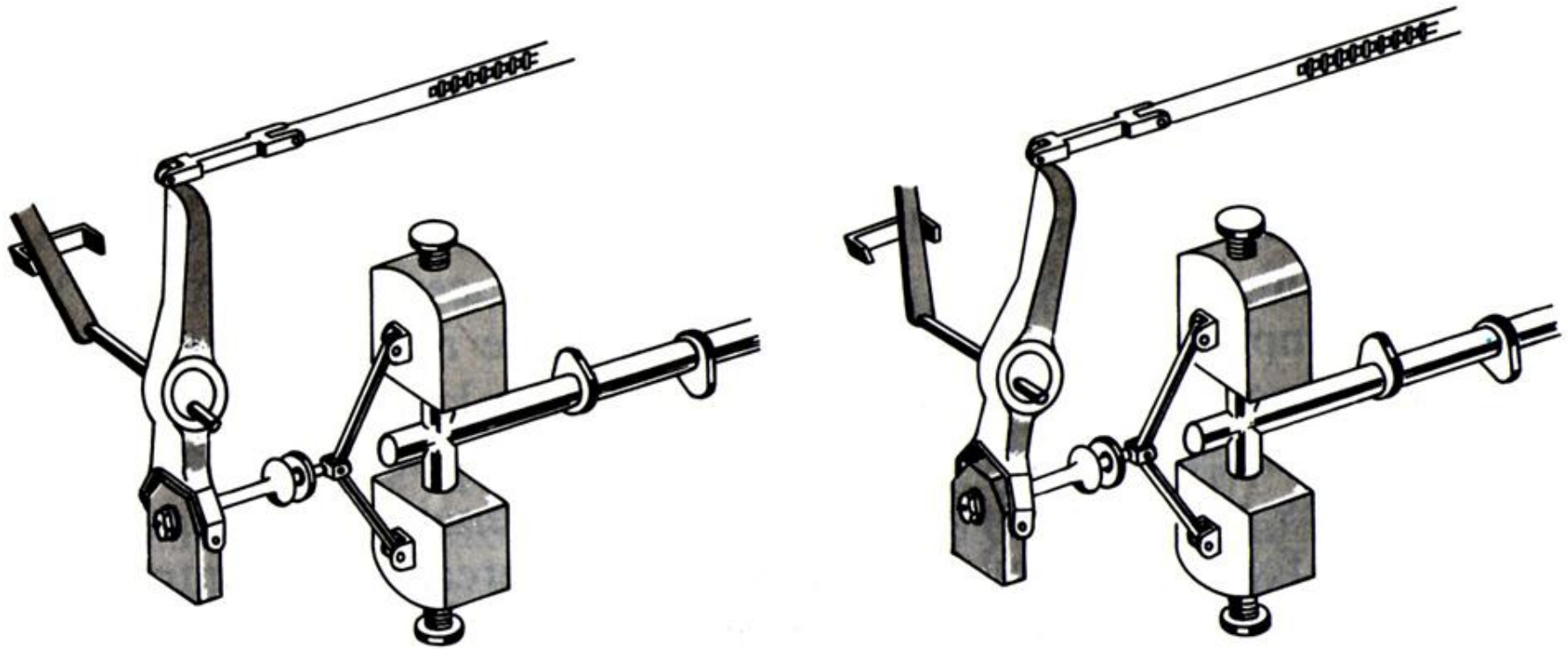

**MENOR**

**MAIOR**

**A quantidade de combustível injetada sendo  
função da carga aplicada**

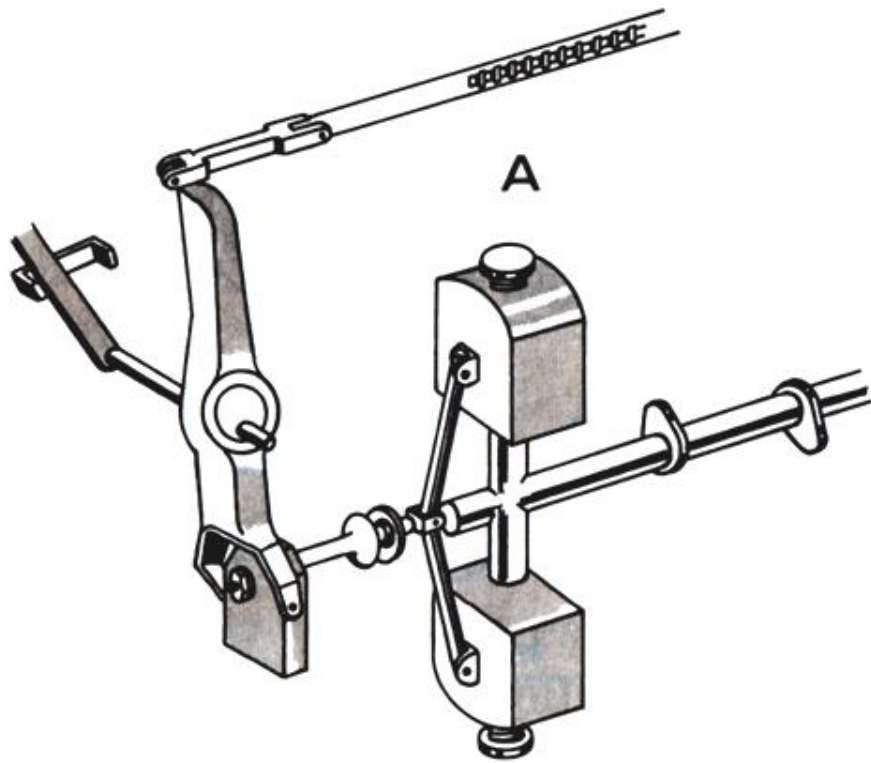

**MENOR**

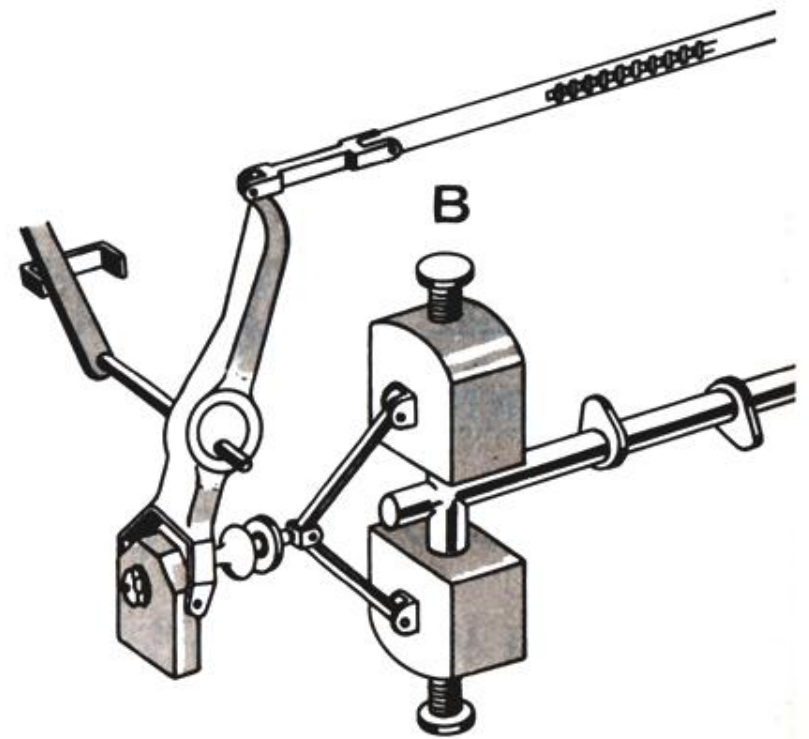

**MAIOR**



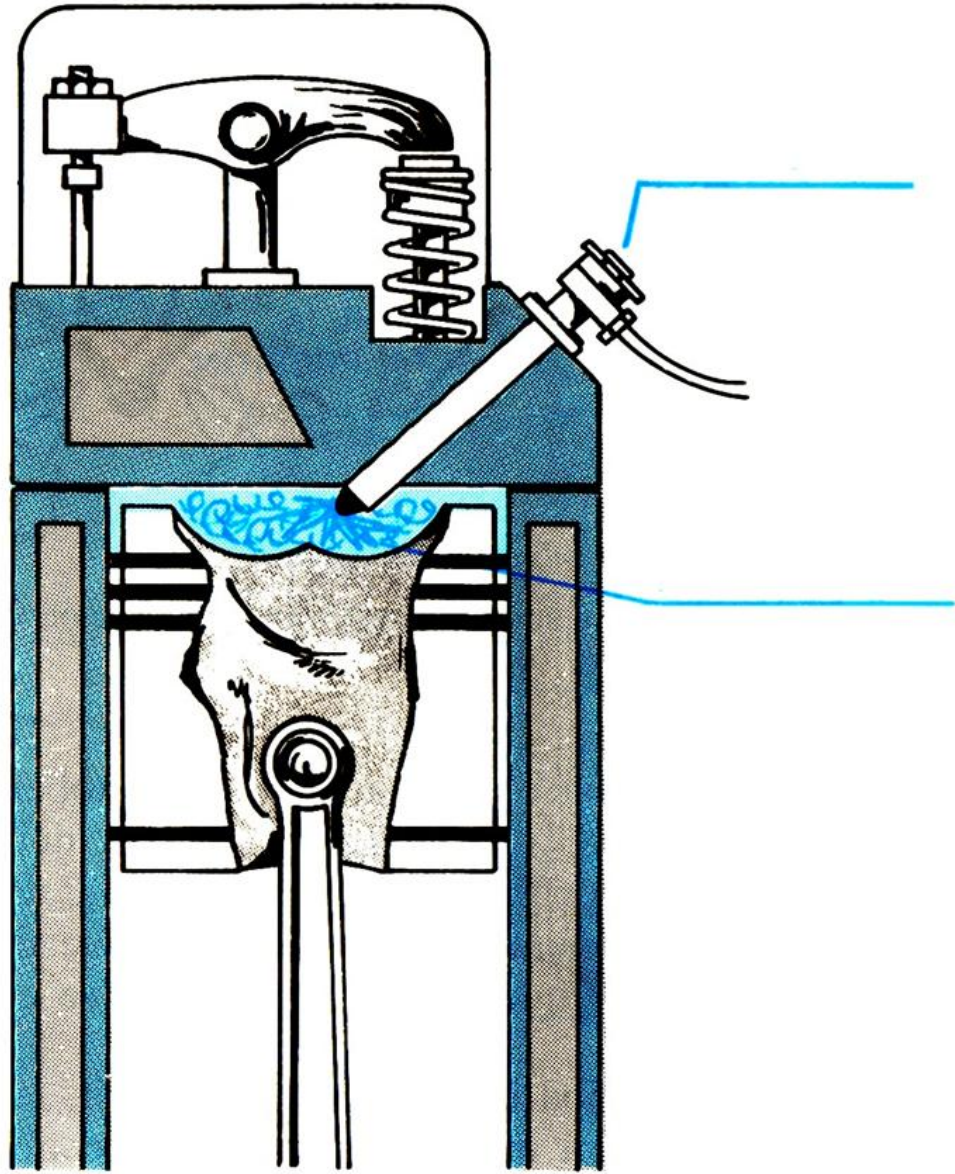



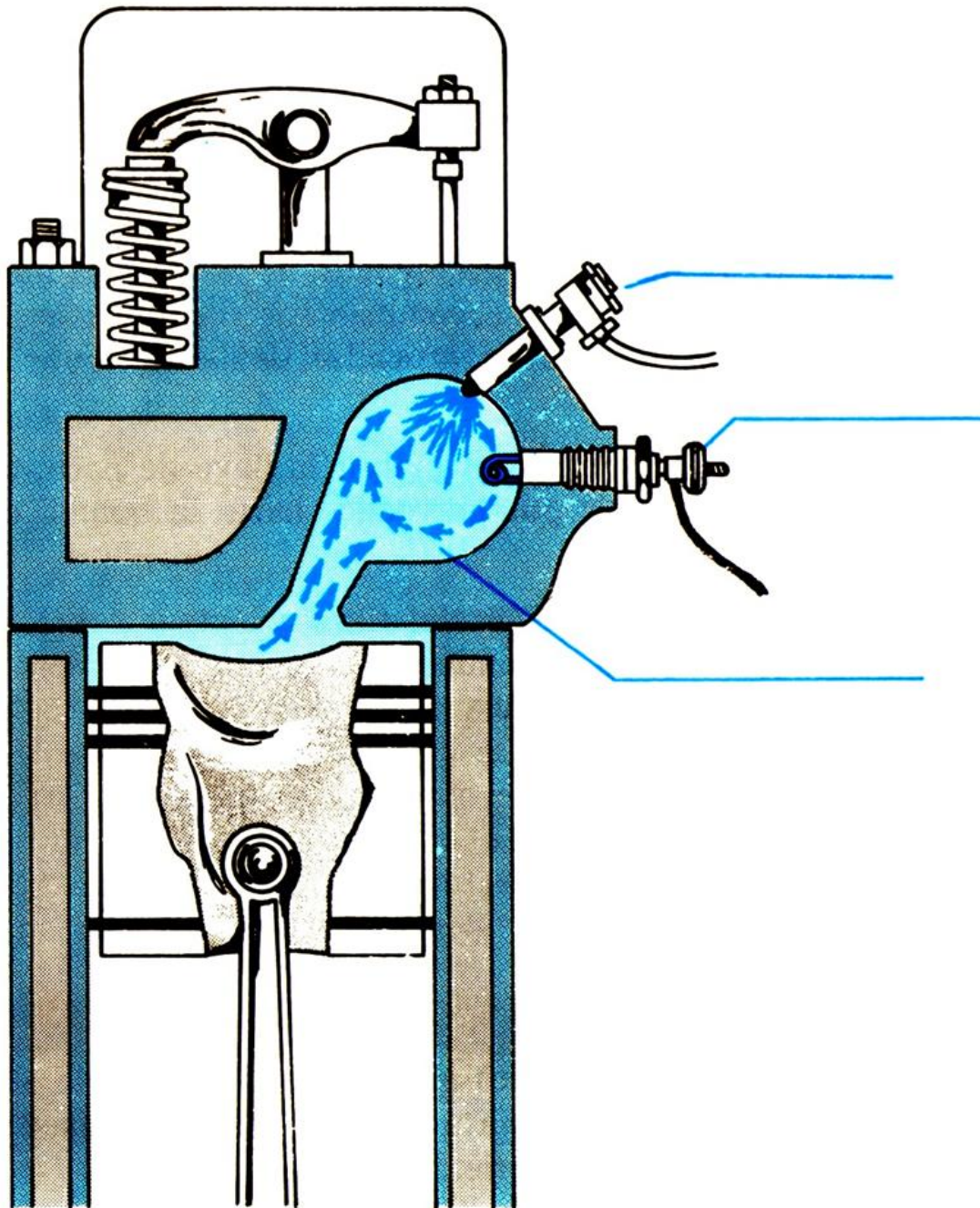

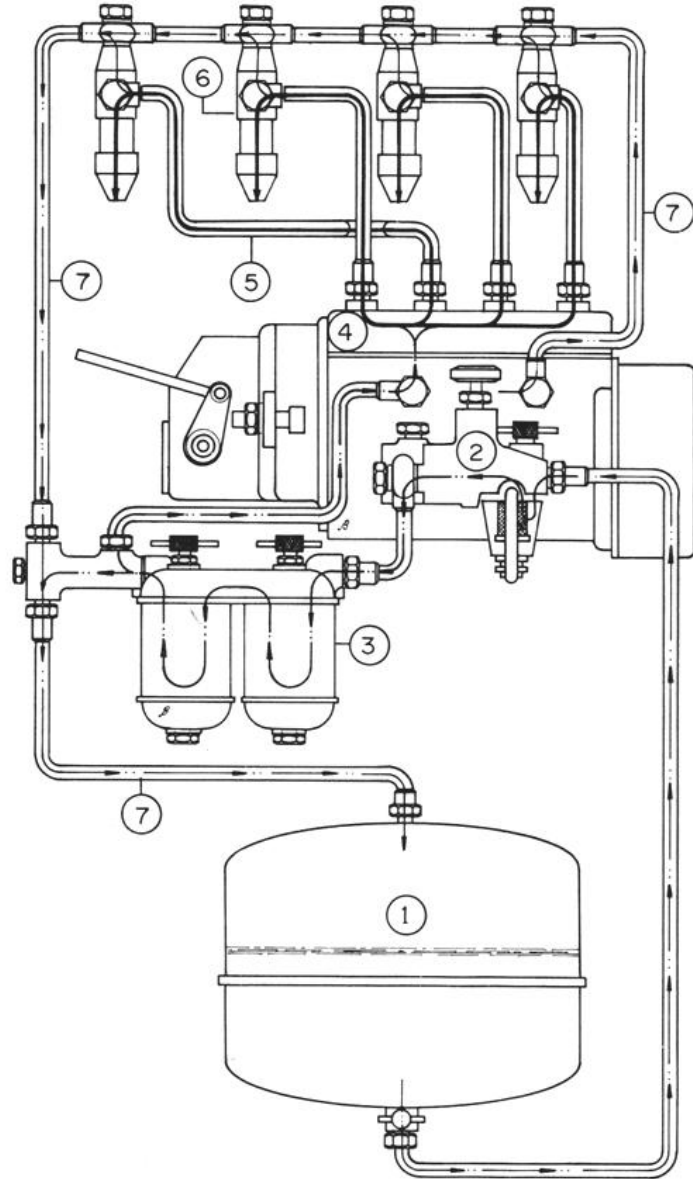

# **Sistema de Alimentação de ar dos Motores de Combustão Interna de Ciclo Diesel**

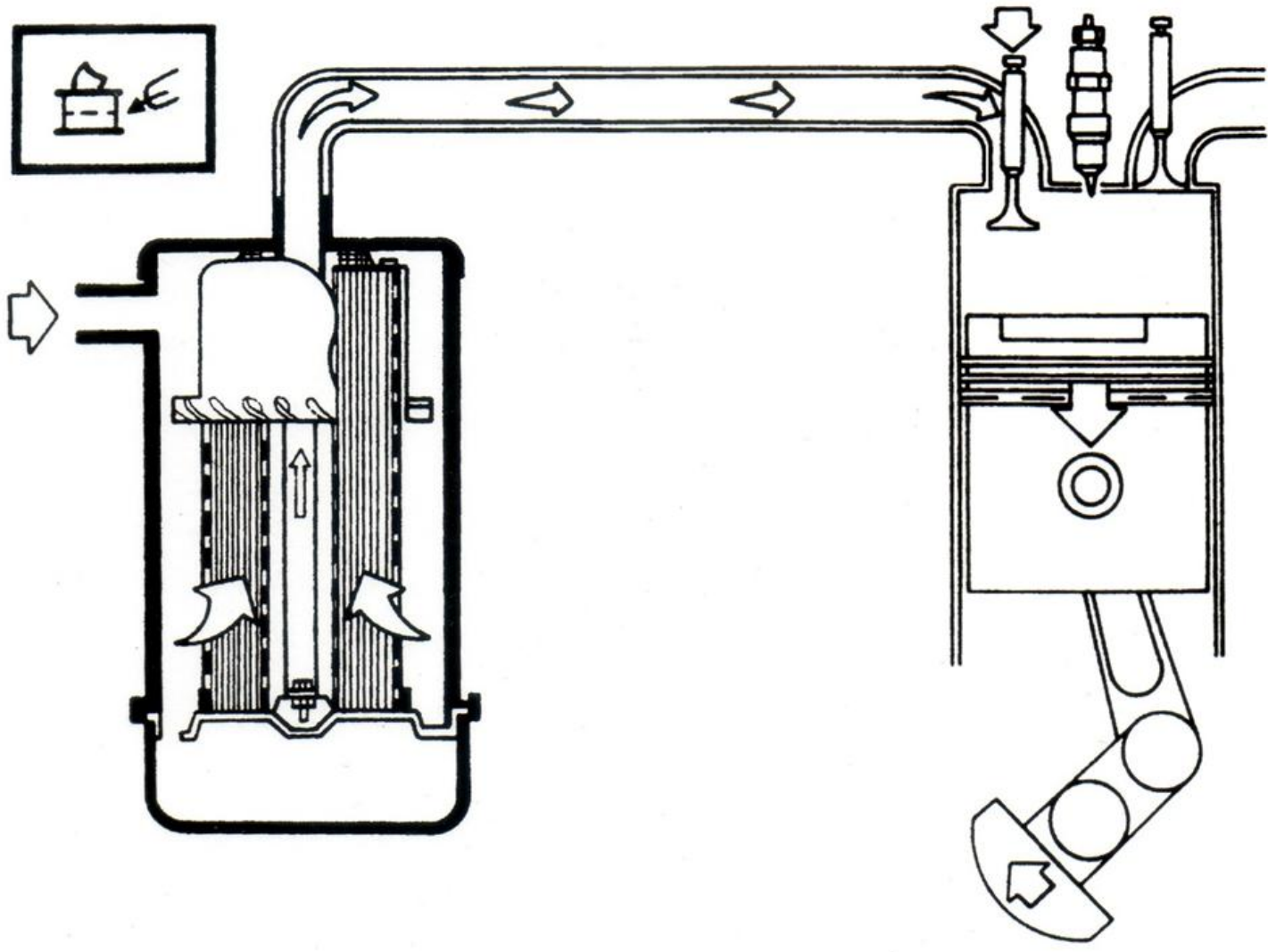

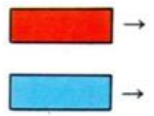
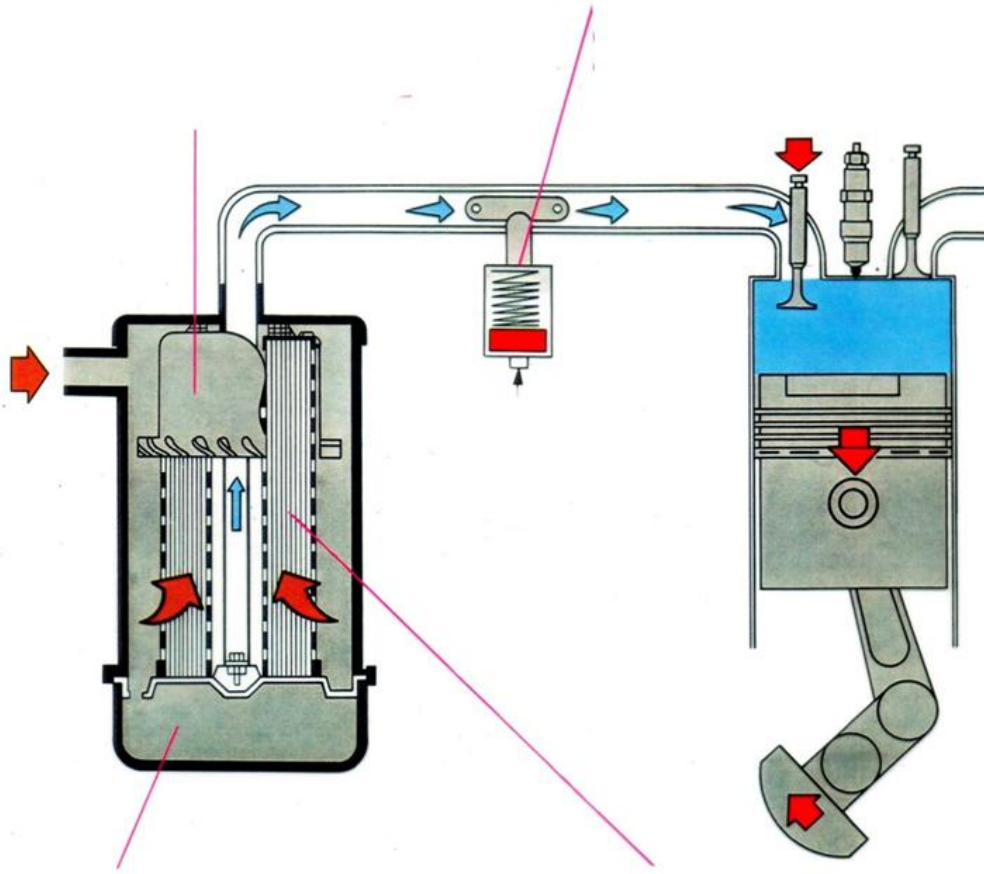



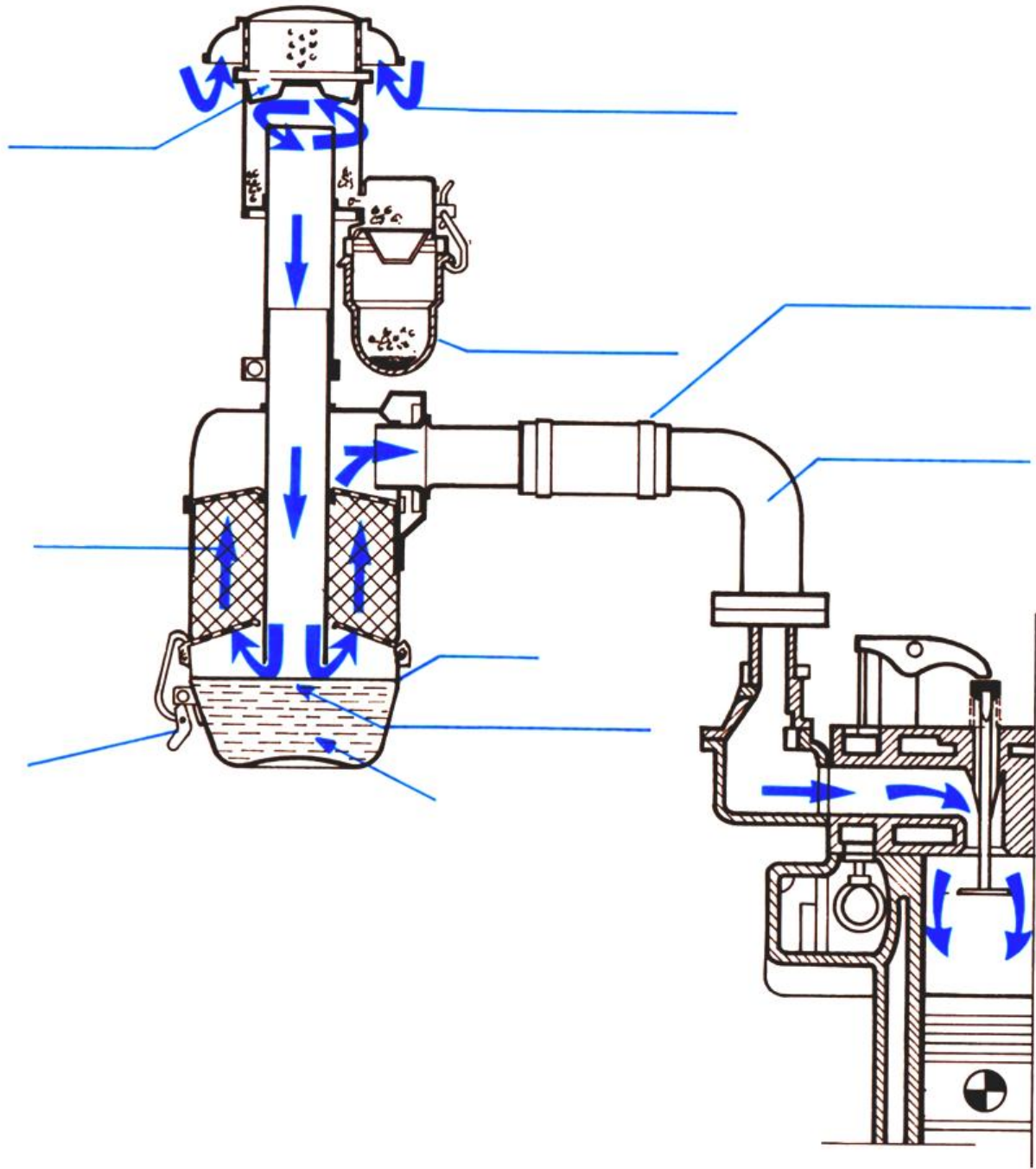

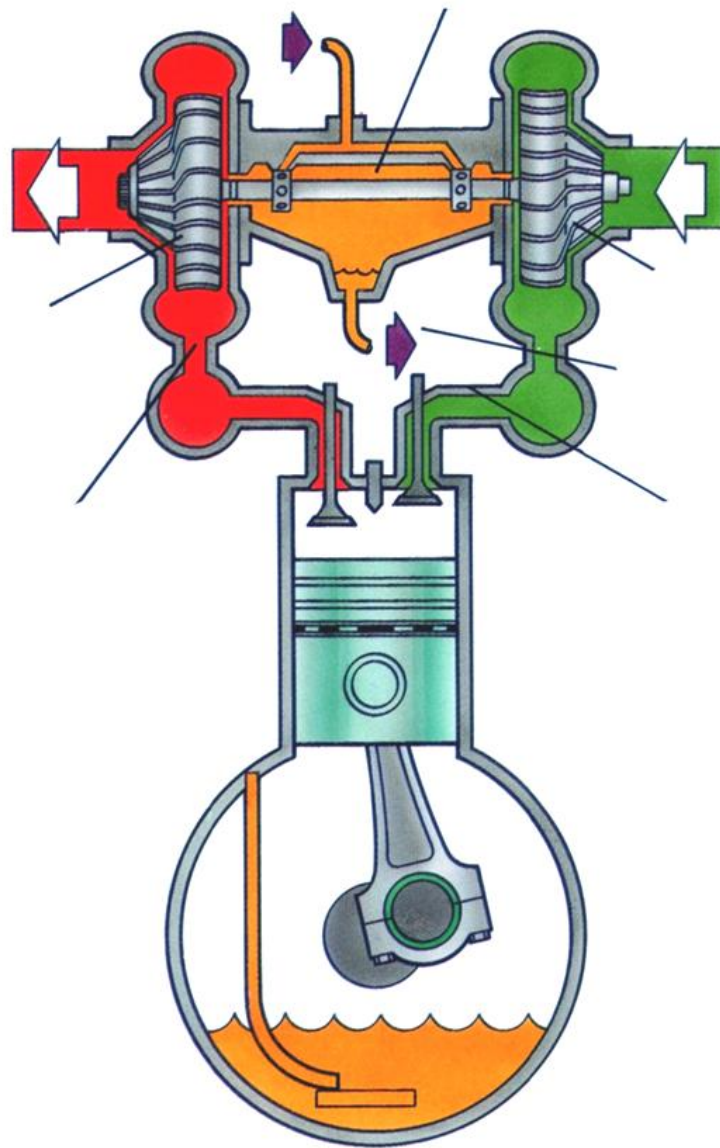

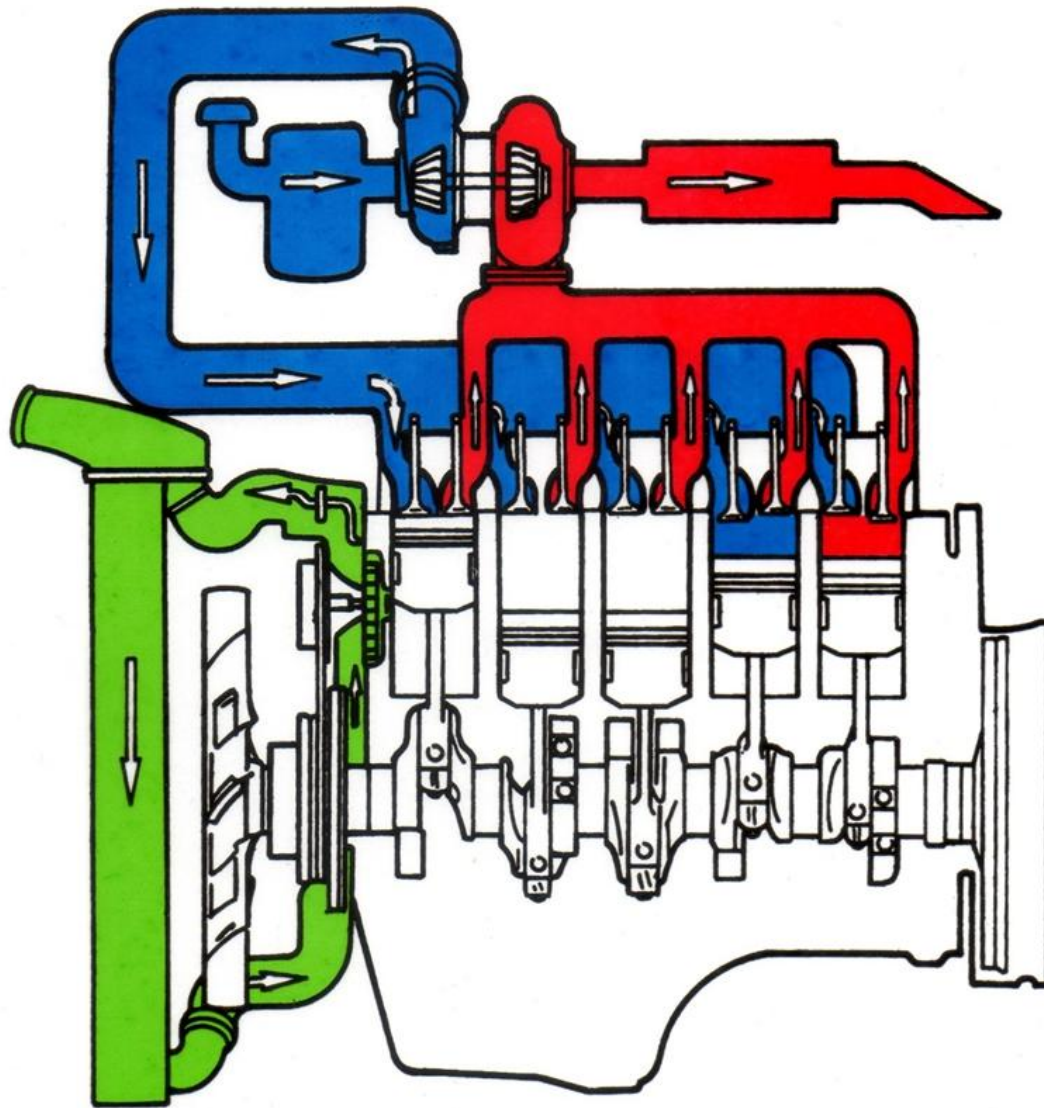

- Escape**
- Admissão**
- Arrefecimento**

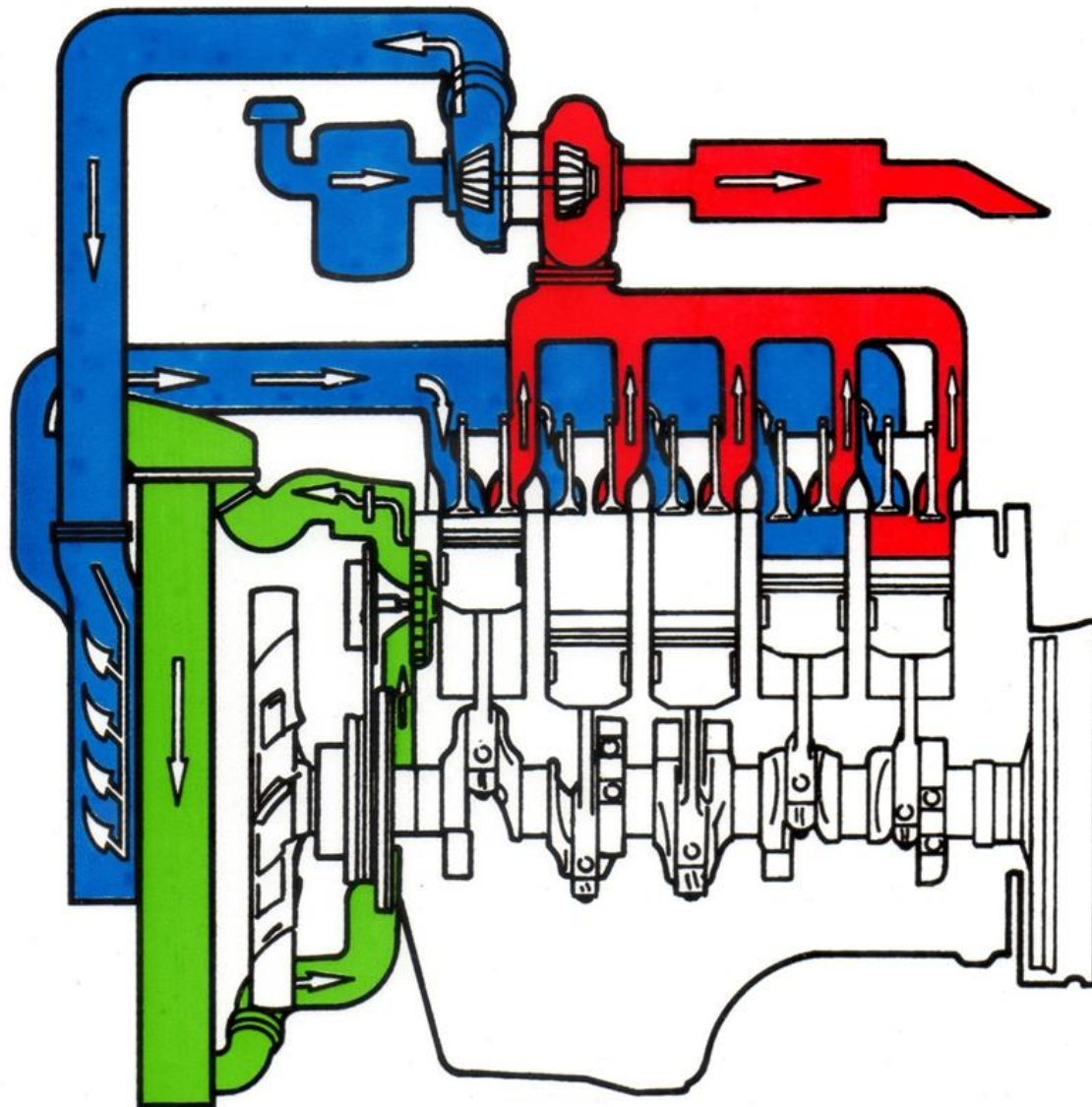

- Escape**
- Admissão**
- Arrefecimento**

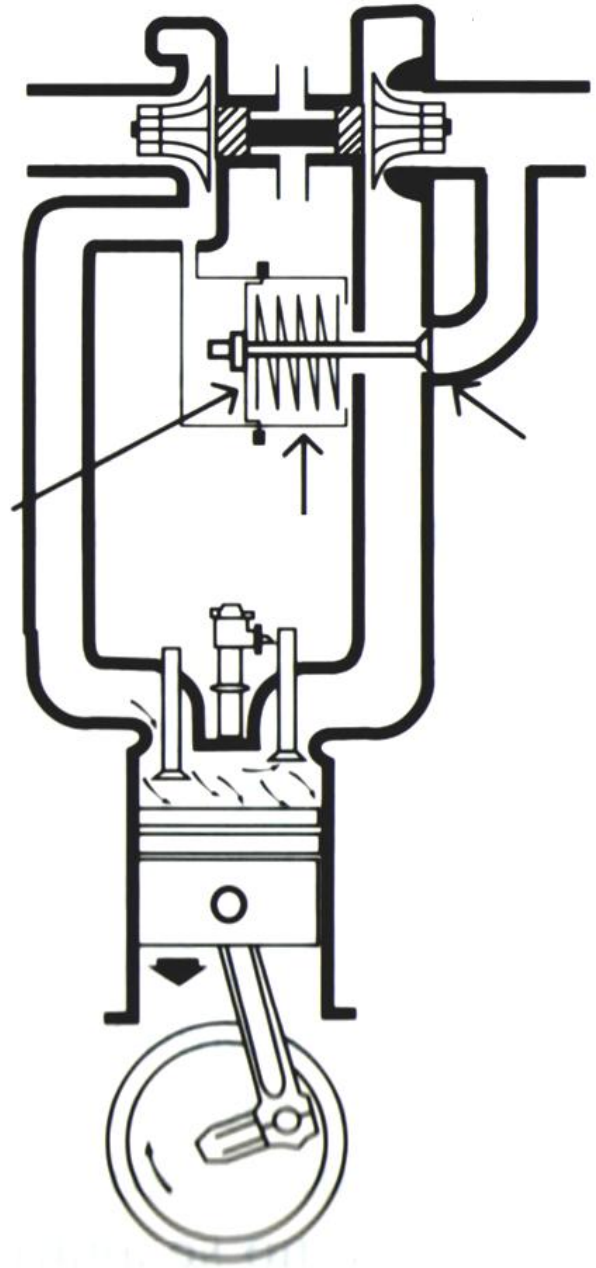



# **Sistema de Lubrificação dos Motores de Combustão Interna de Ciclo Diesel**

# Secção de uma superfície metálica ampliada

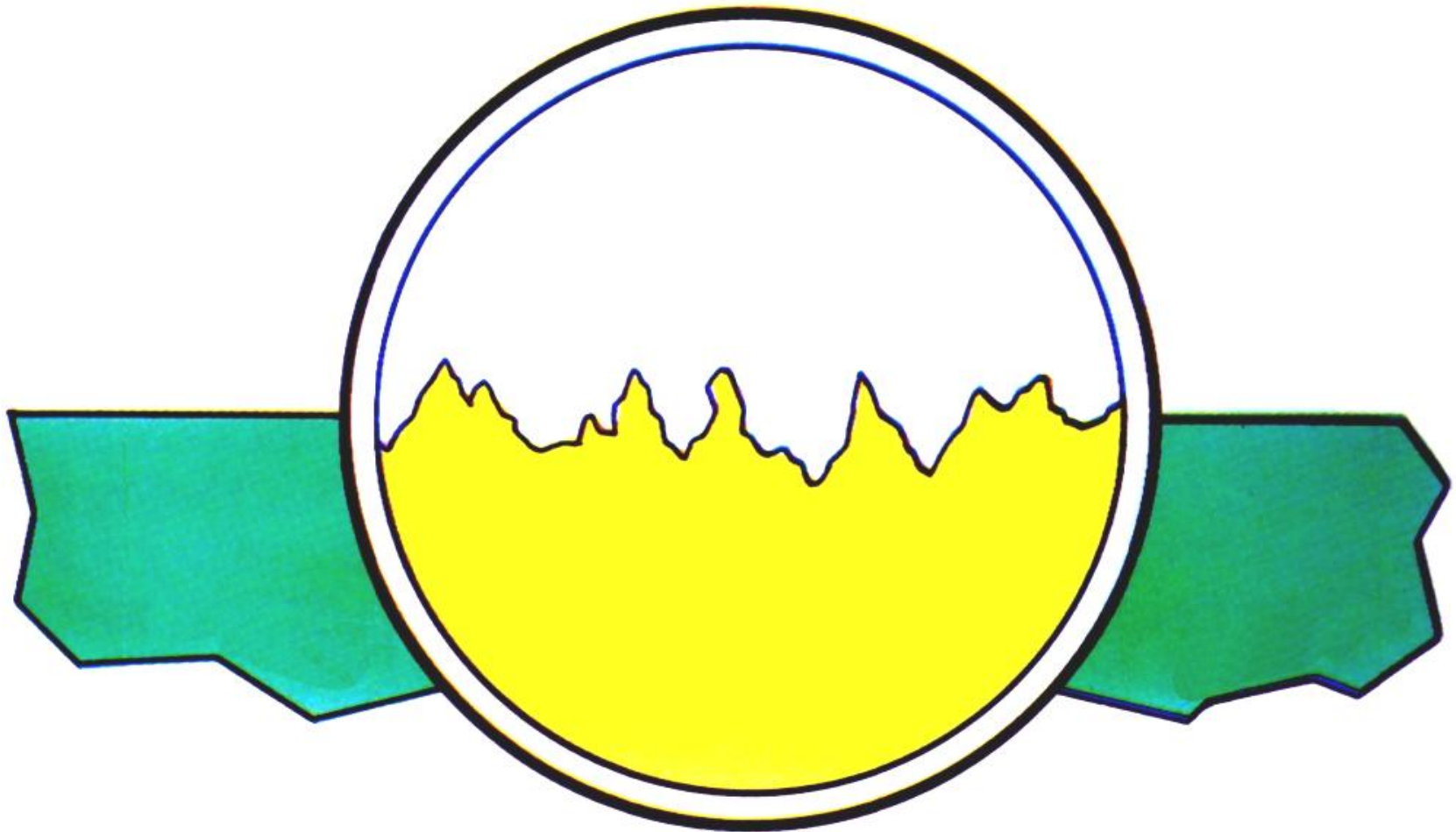

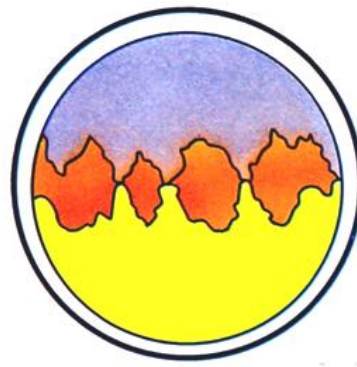

**Contacto de duas superfícies metálicas**

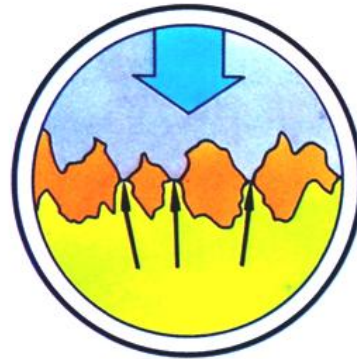

**Pontos de contacto entre duas superfícies metálicas sob carga**

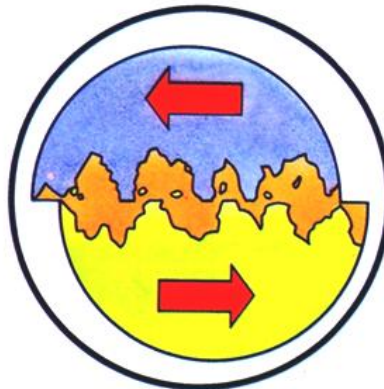

**Movimento relativo entre duas superfícies metálicas**

Lubrificante

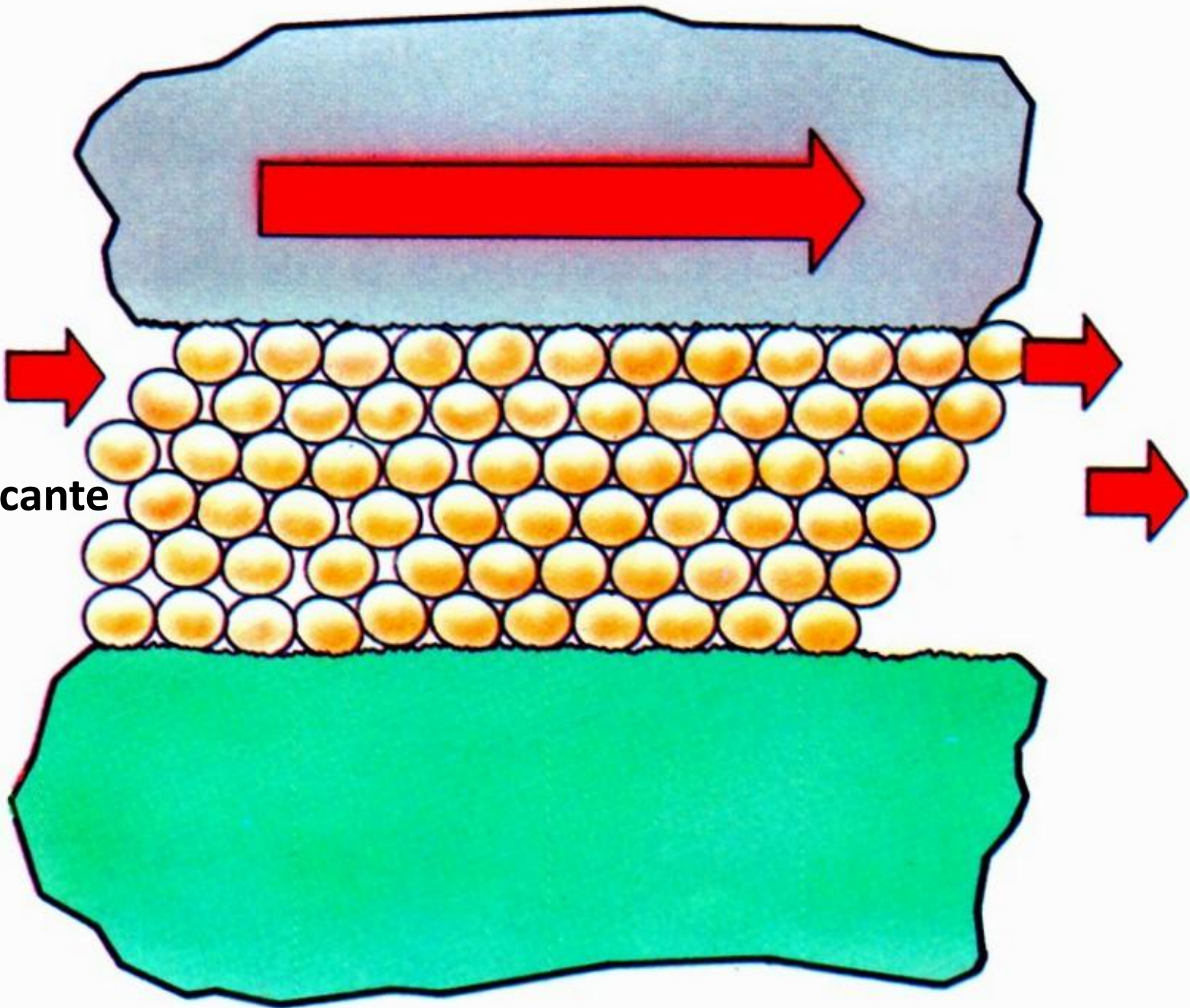



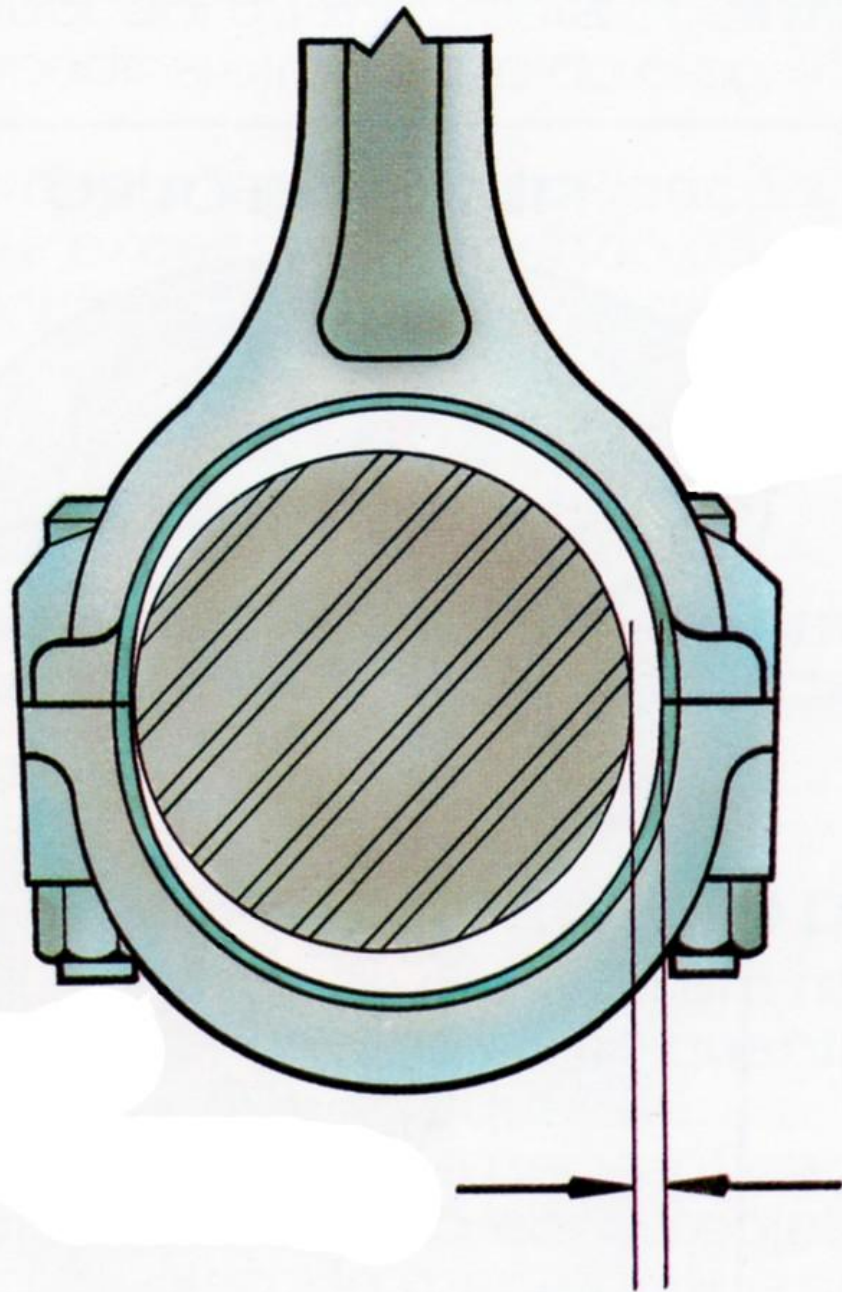



# Funções do sistema de lubrificação

- REDUÇÃO DO ATRITO
- REDUÇÃO DO DESGASTE
- DIMINUIÇÃO DO RUÍDO
- AÇÃO ARREFECEDORA
- ELIMINAÇÃO DE IMPUREZAS

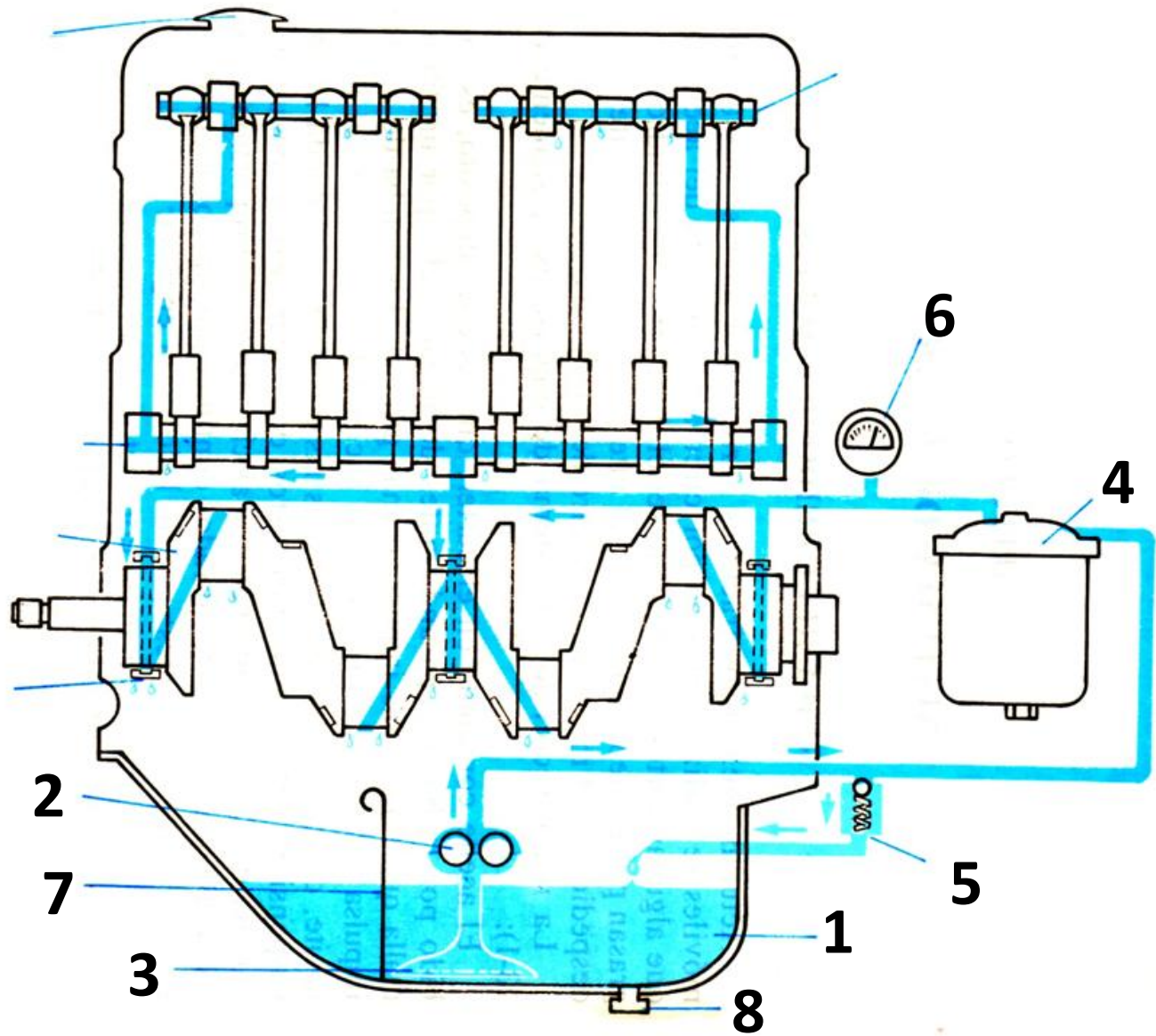

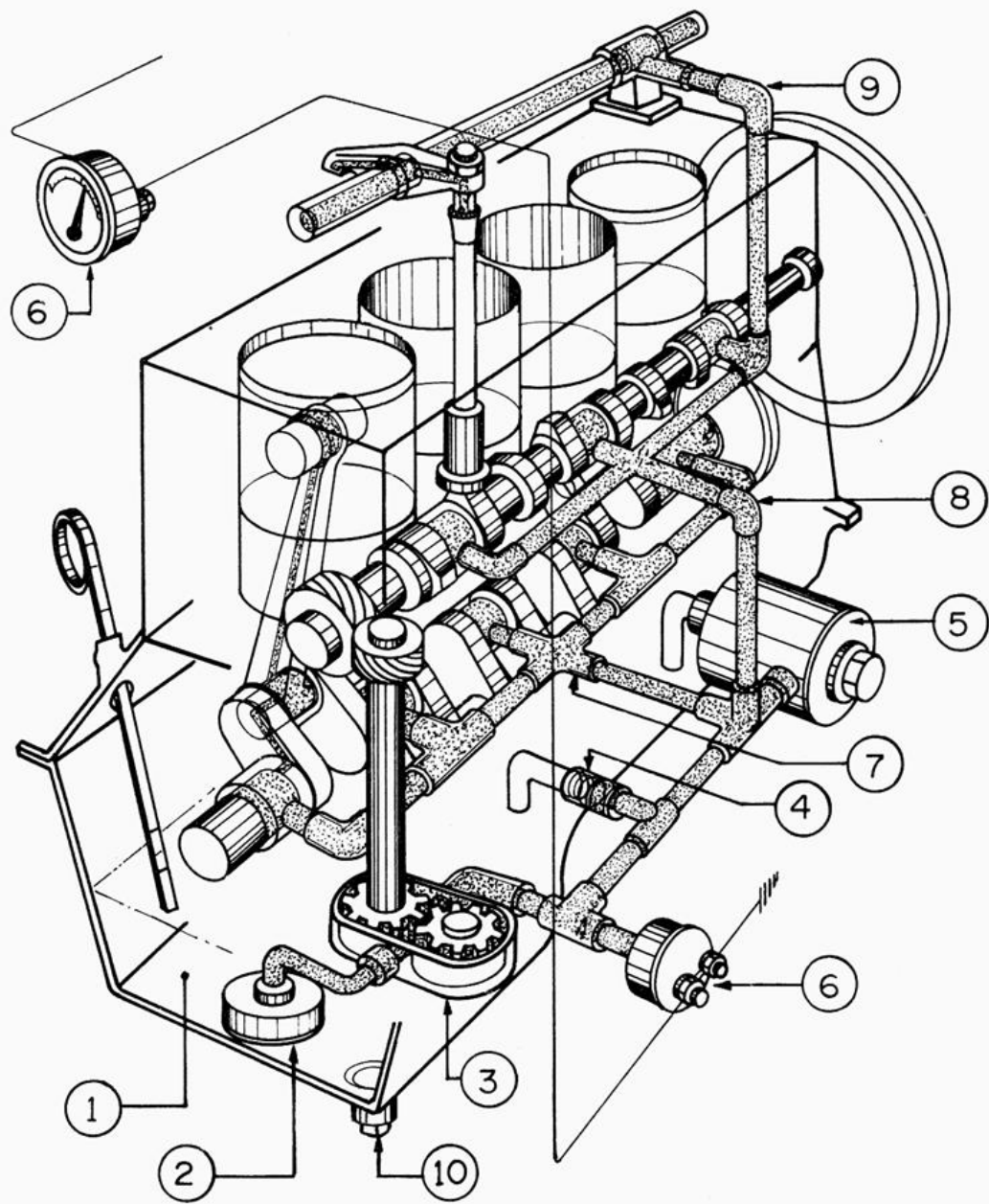

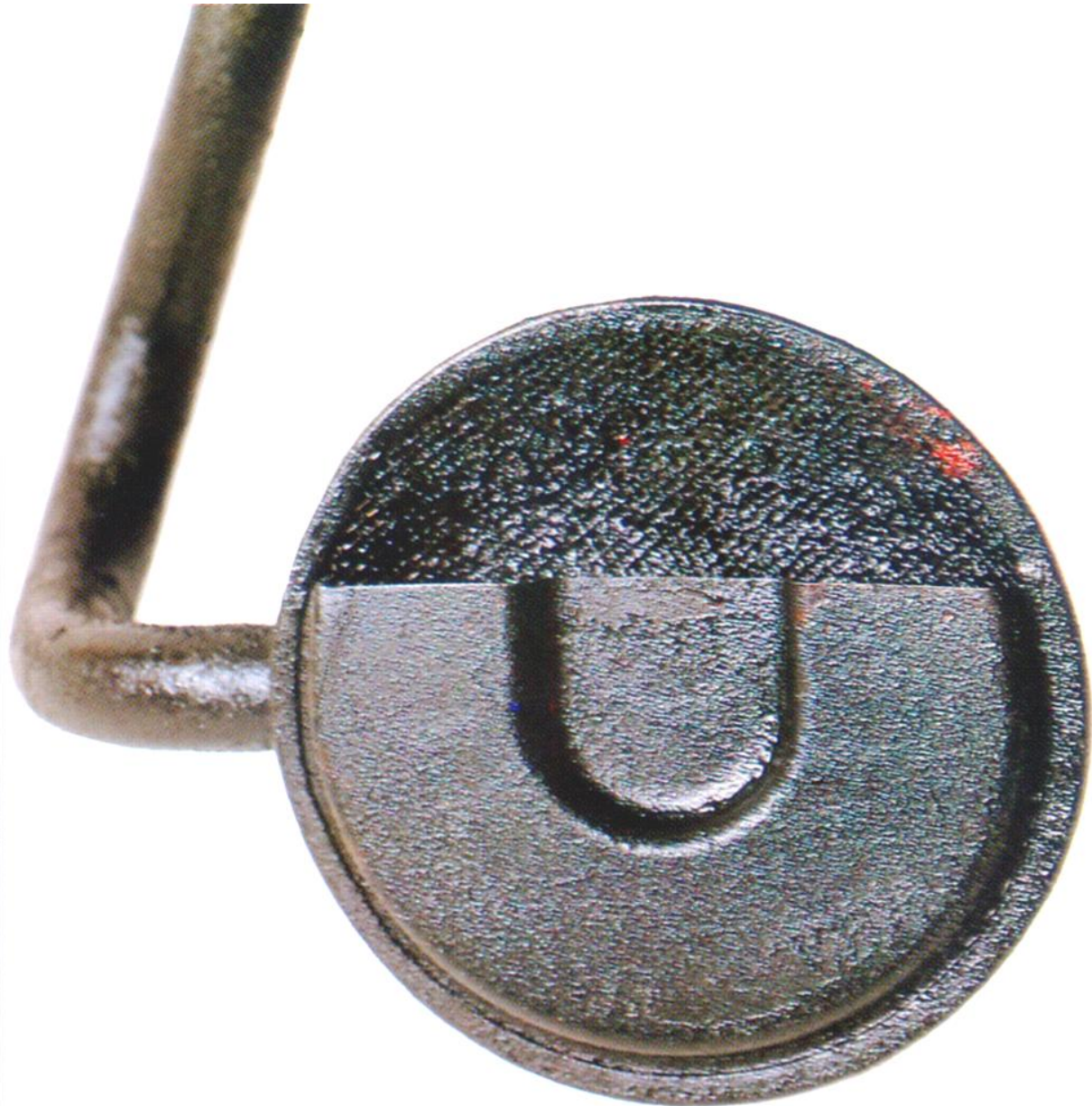



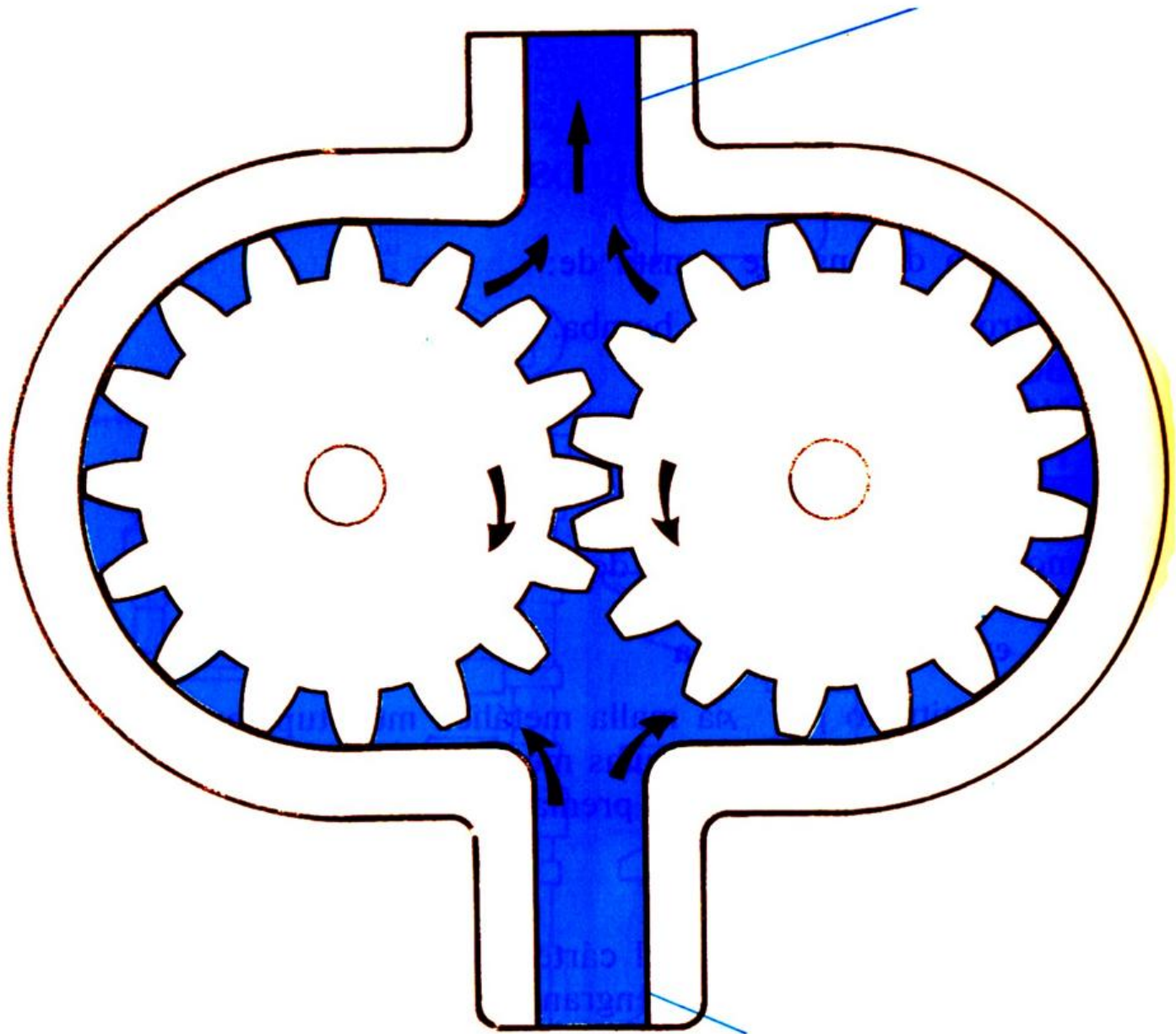

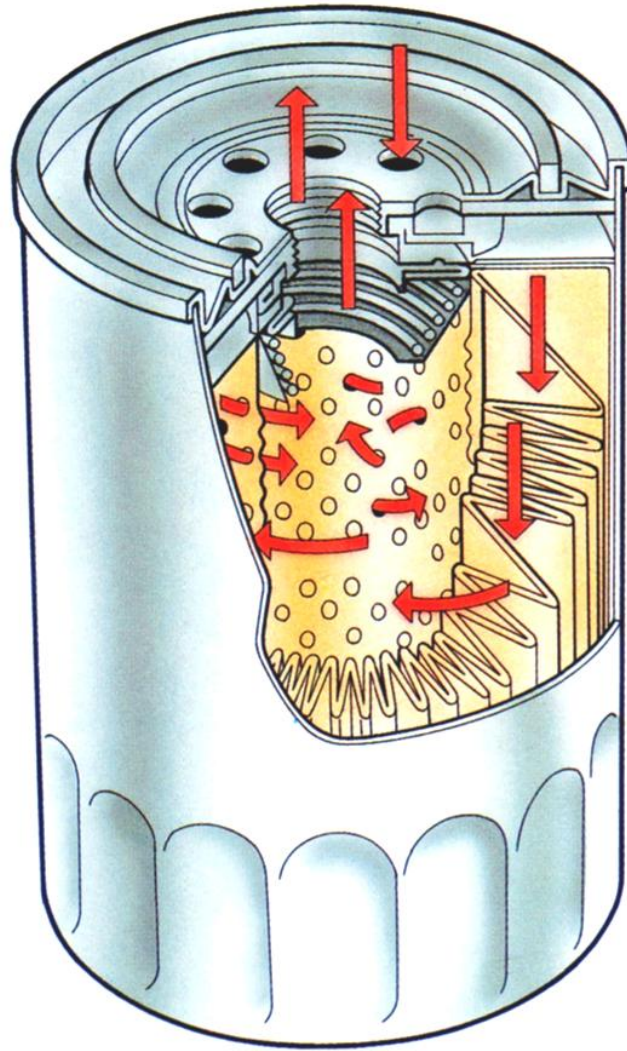

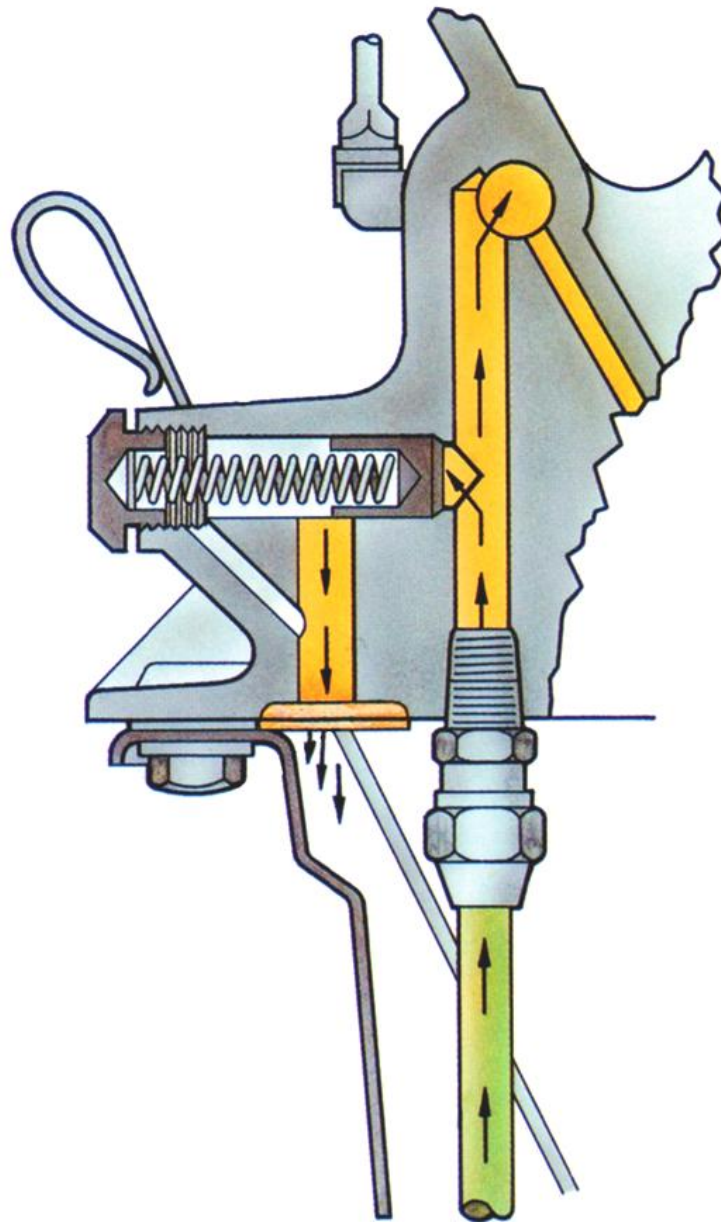

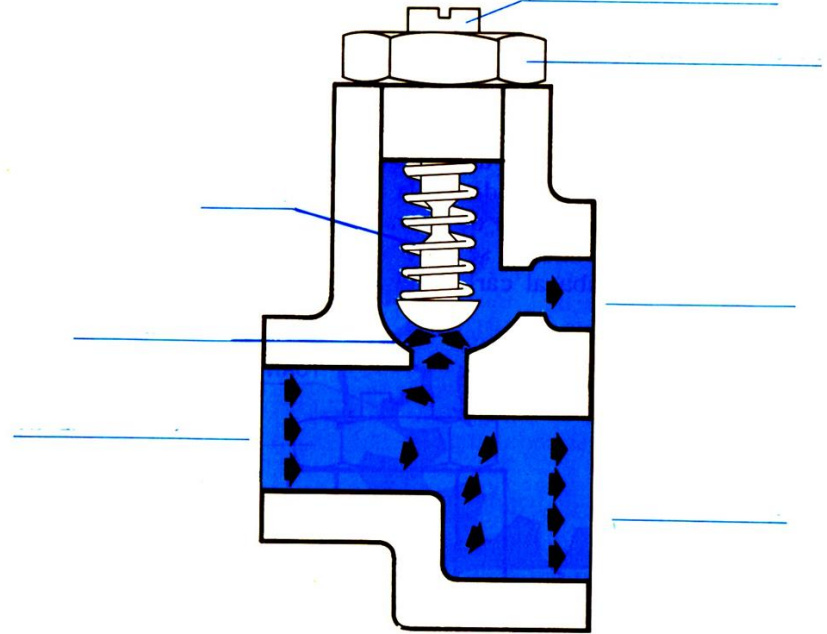
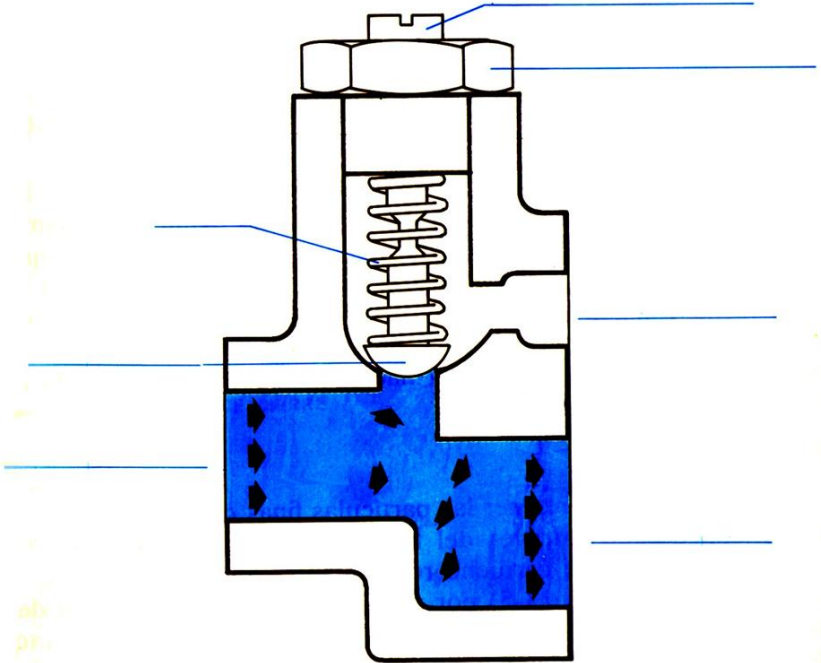

# **Sistema de Arrefecimento dos Motores de Combustão Interna do Ciclo Diesel**



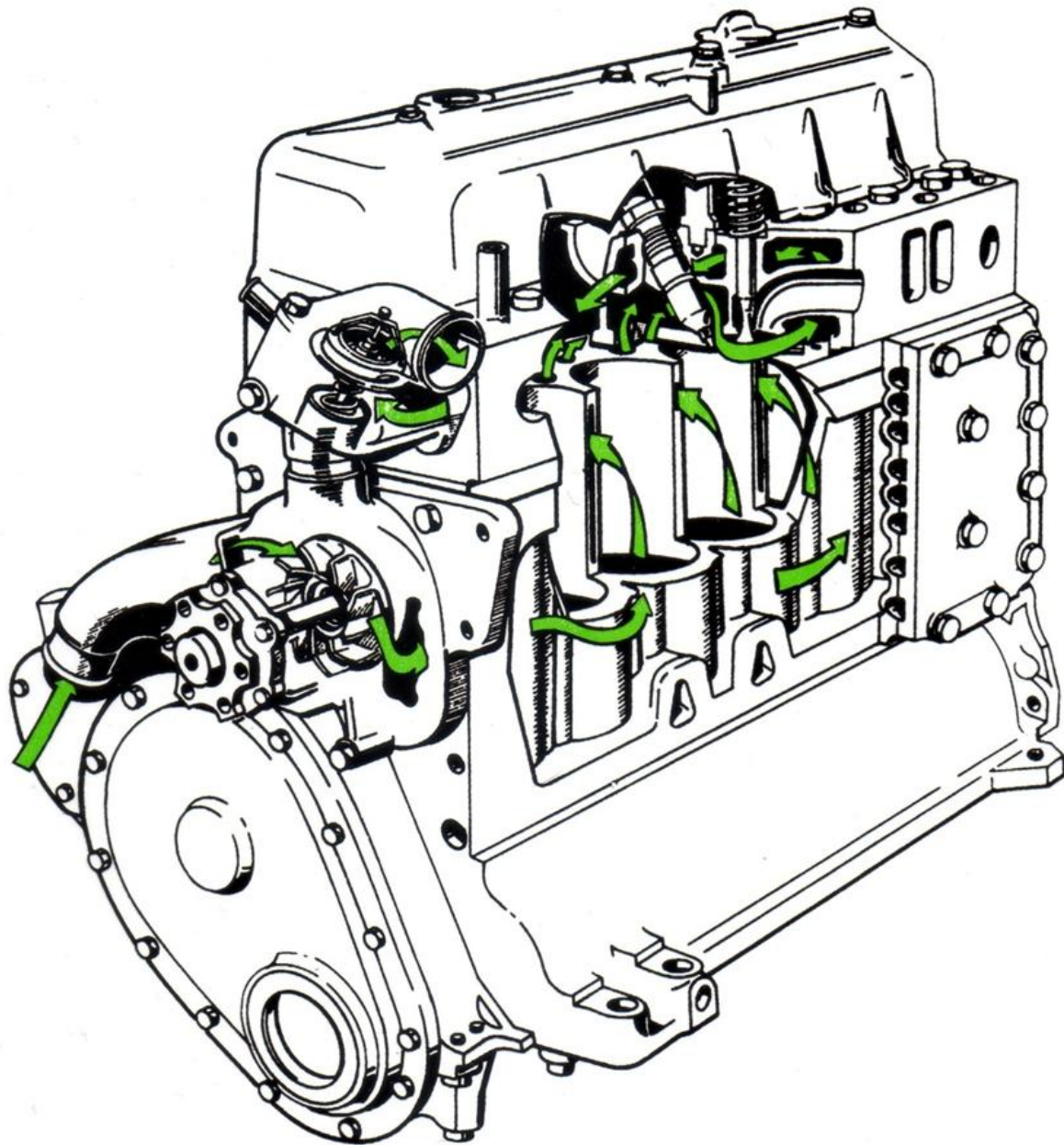

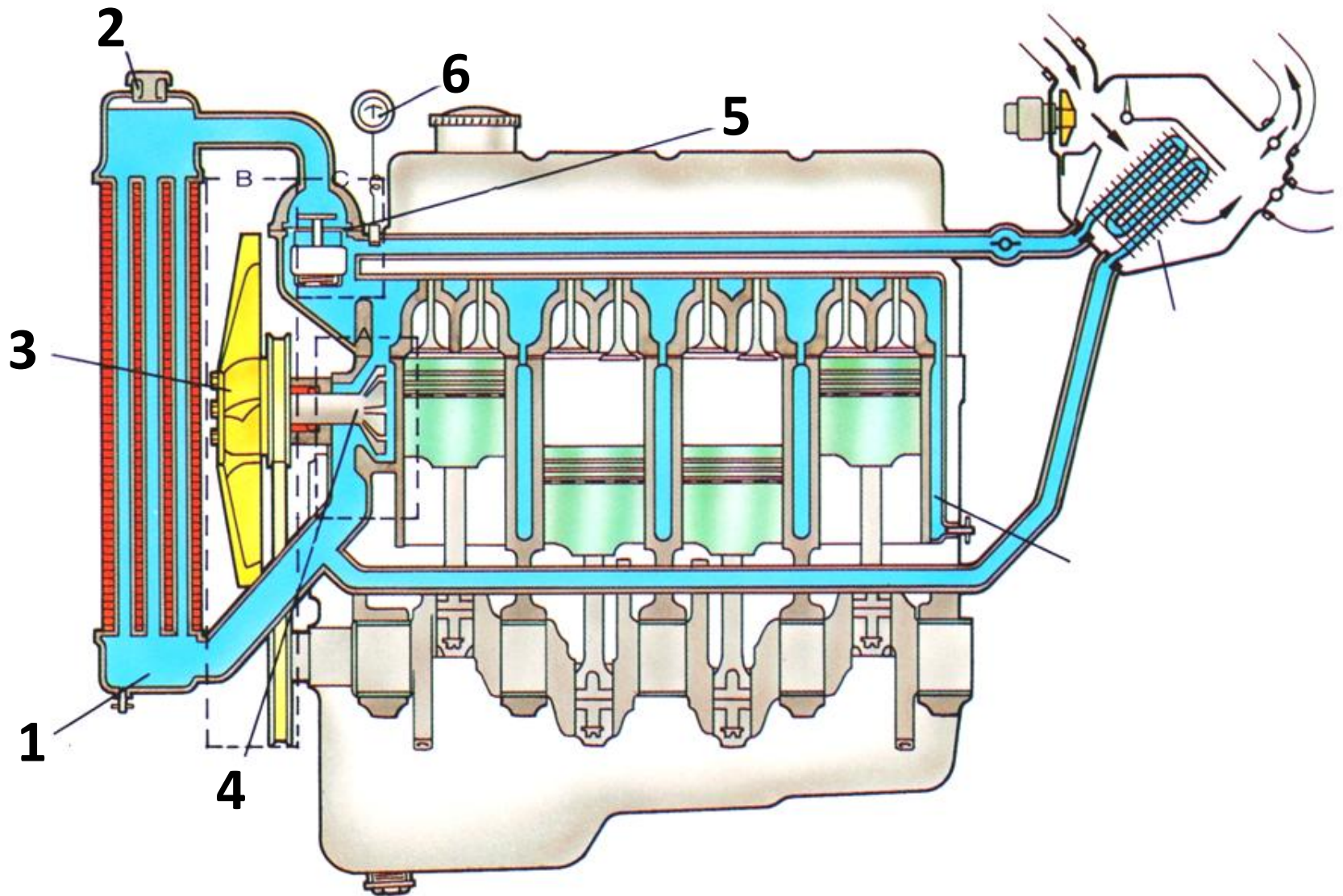

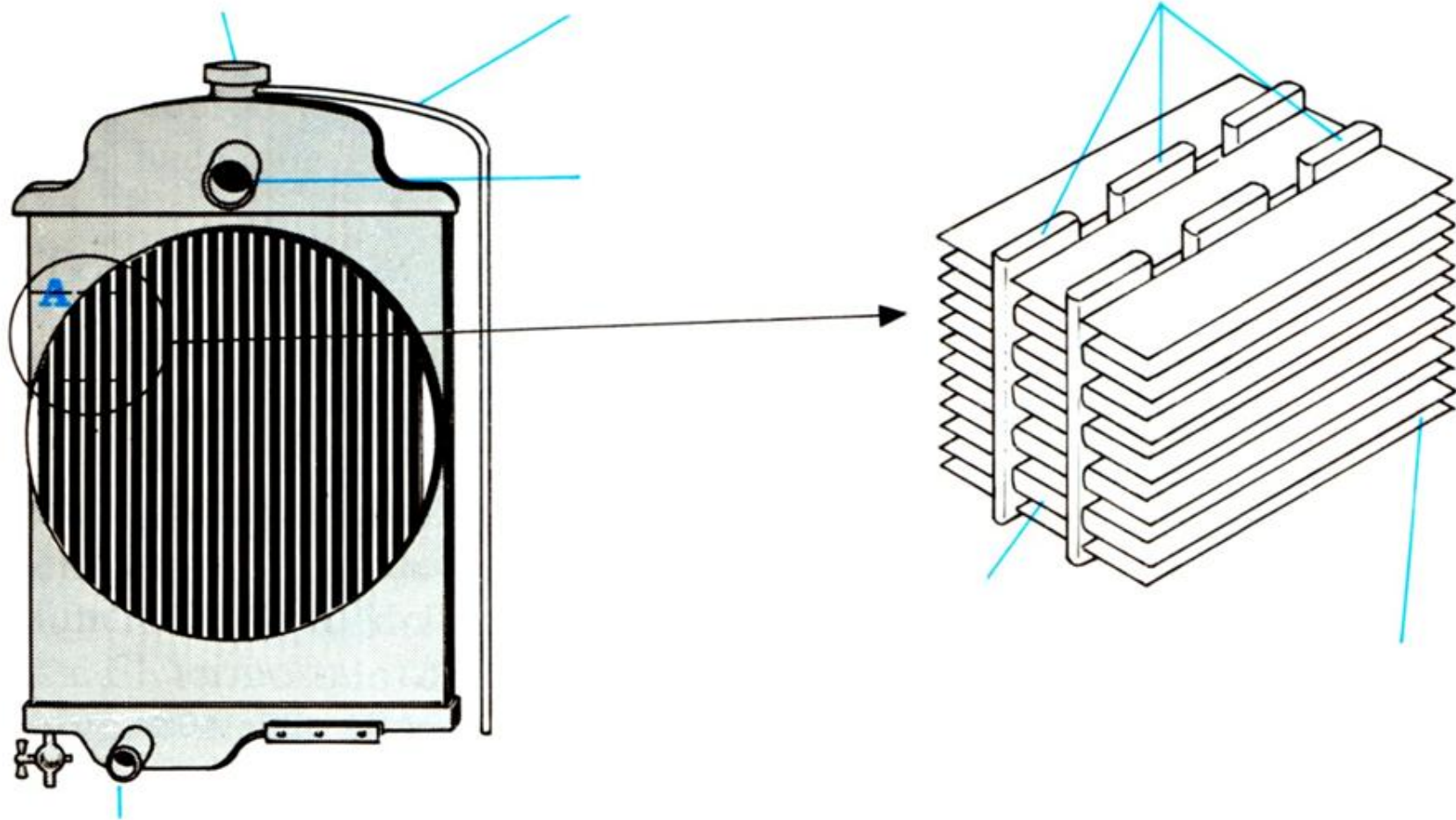



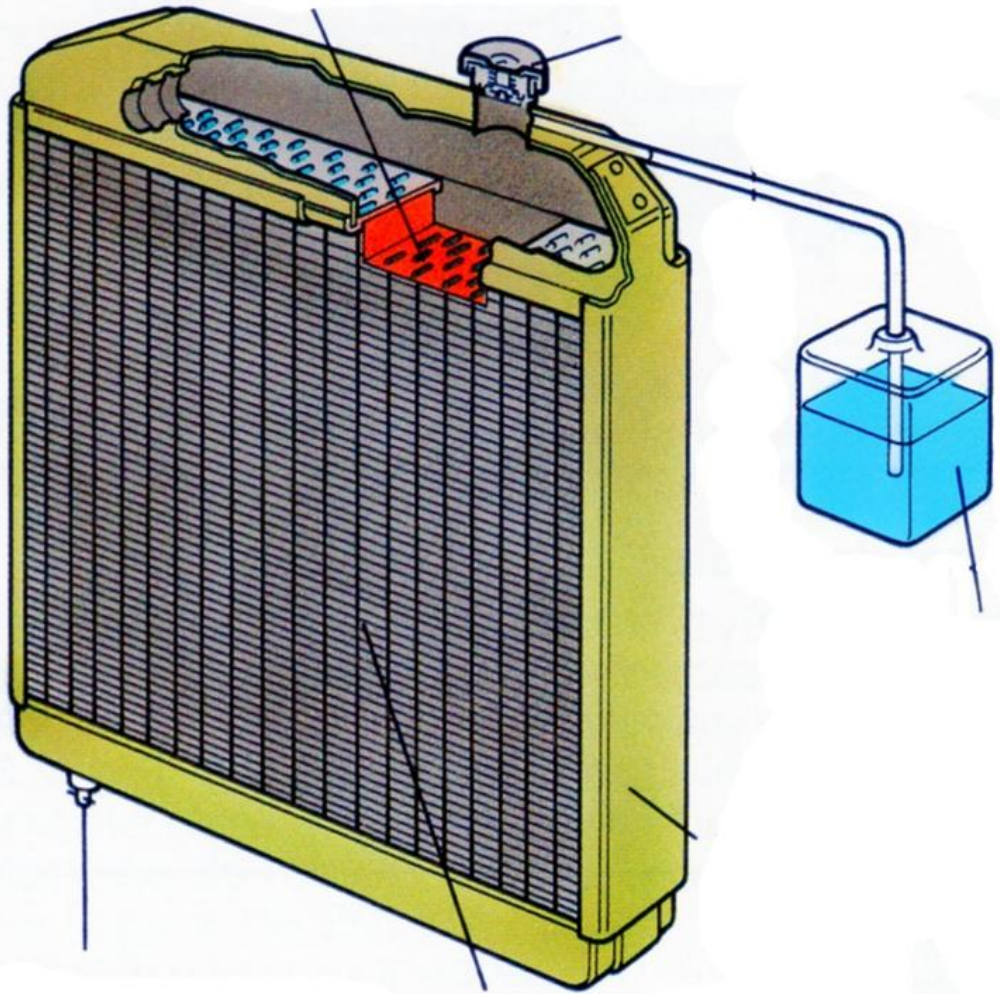

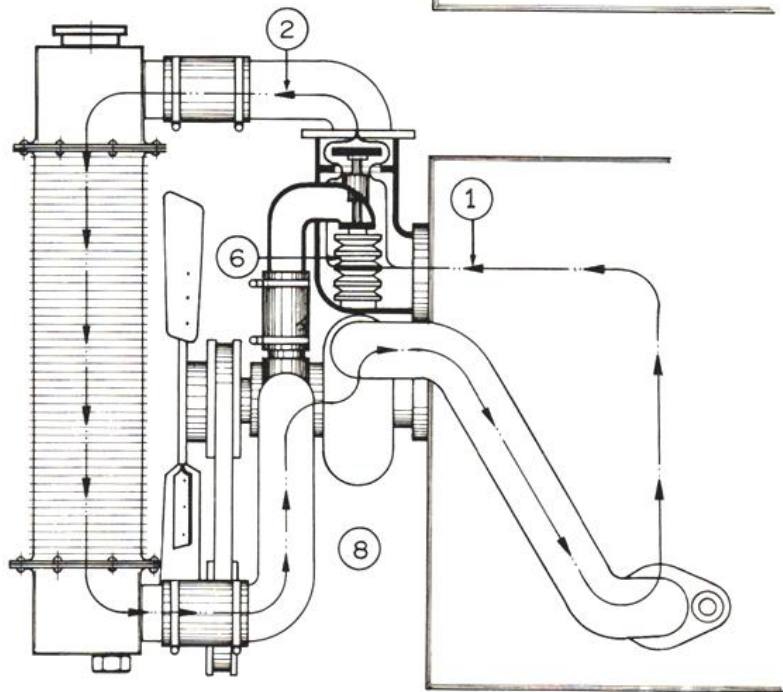
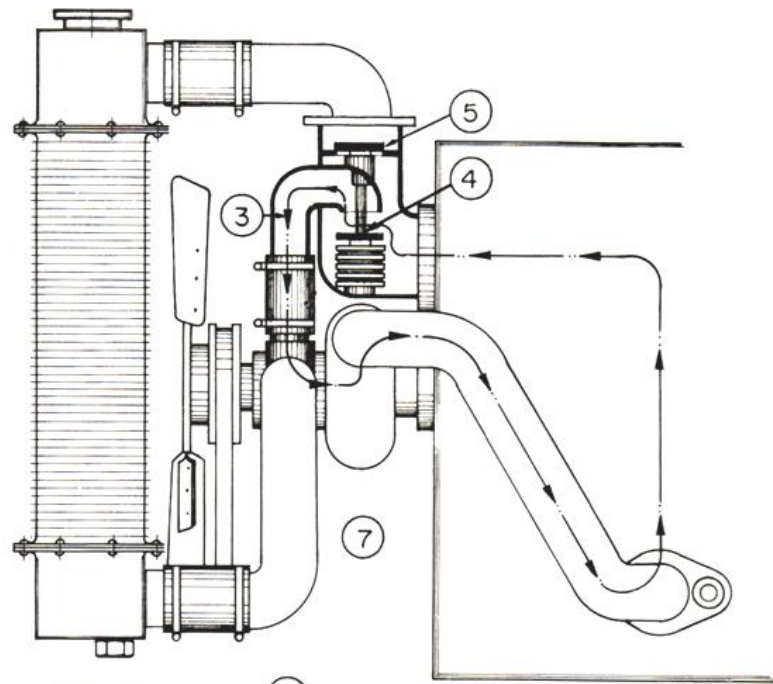



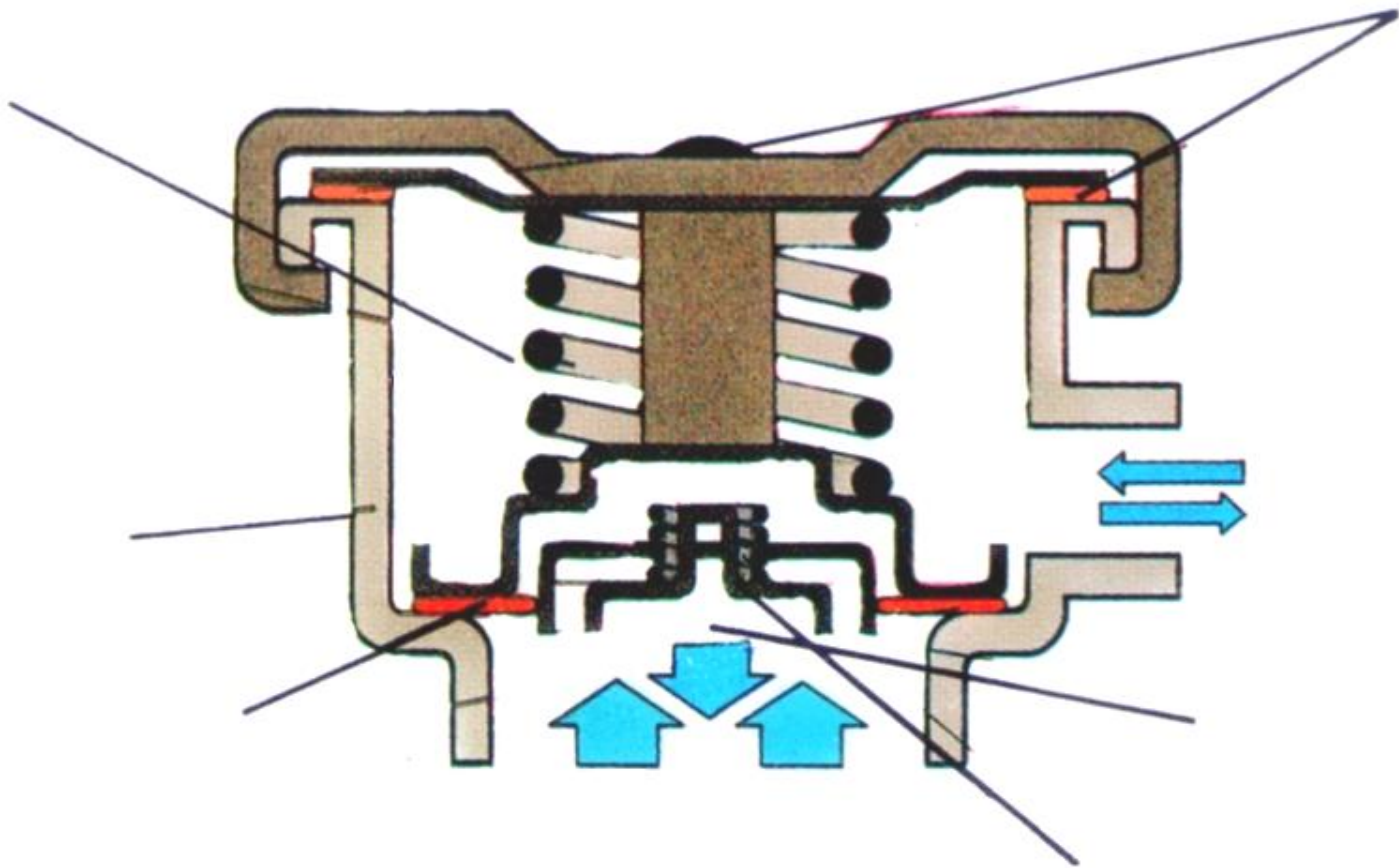

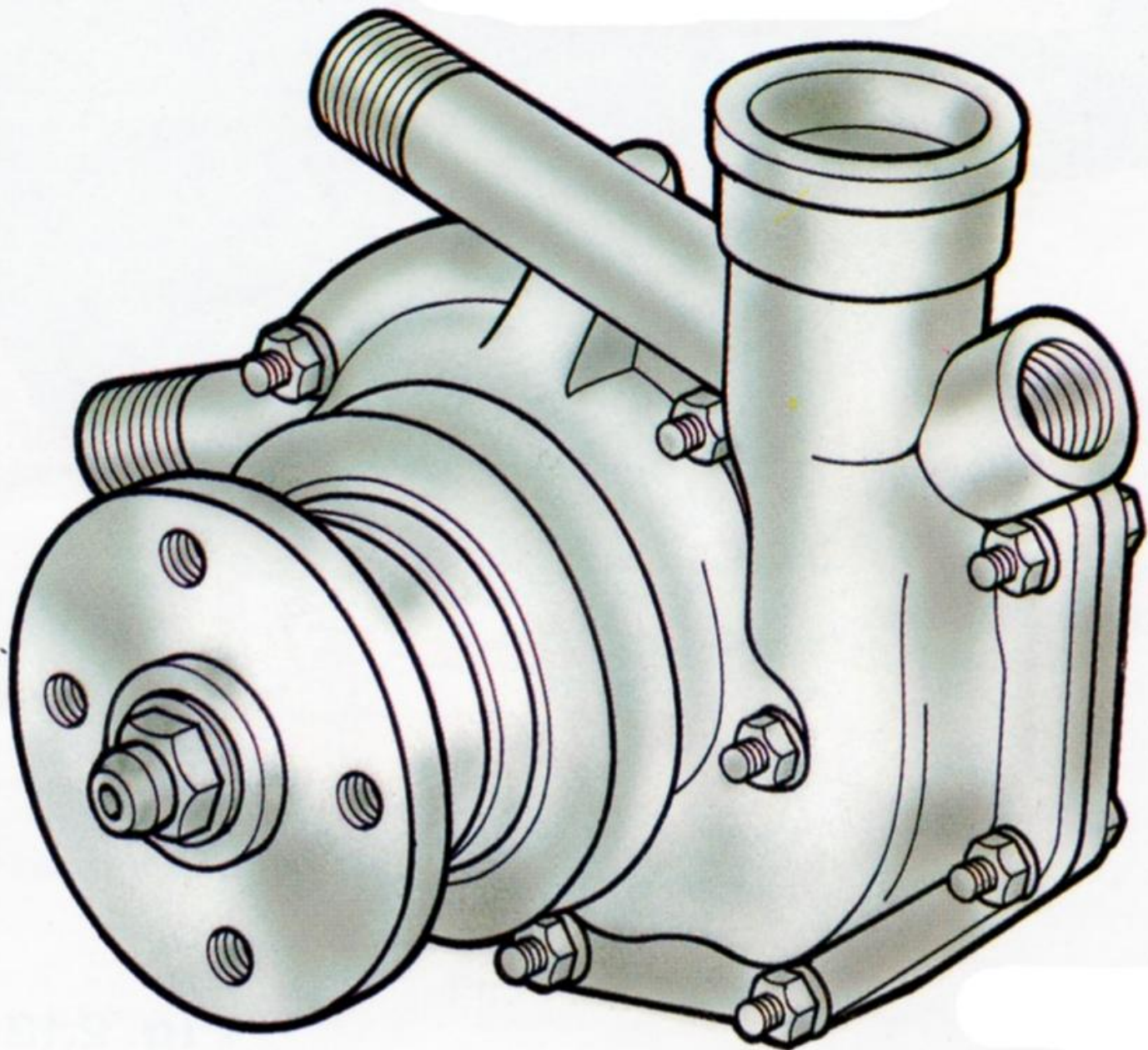

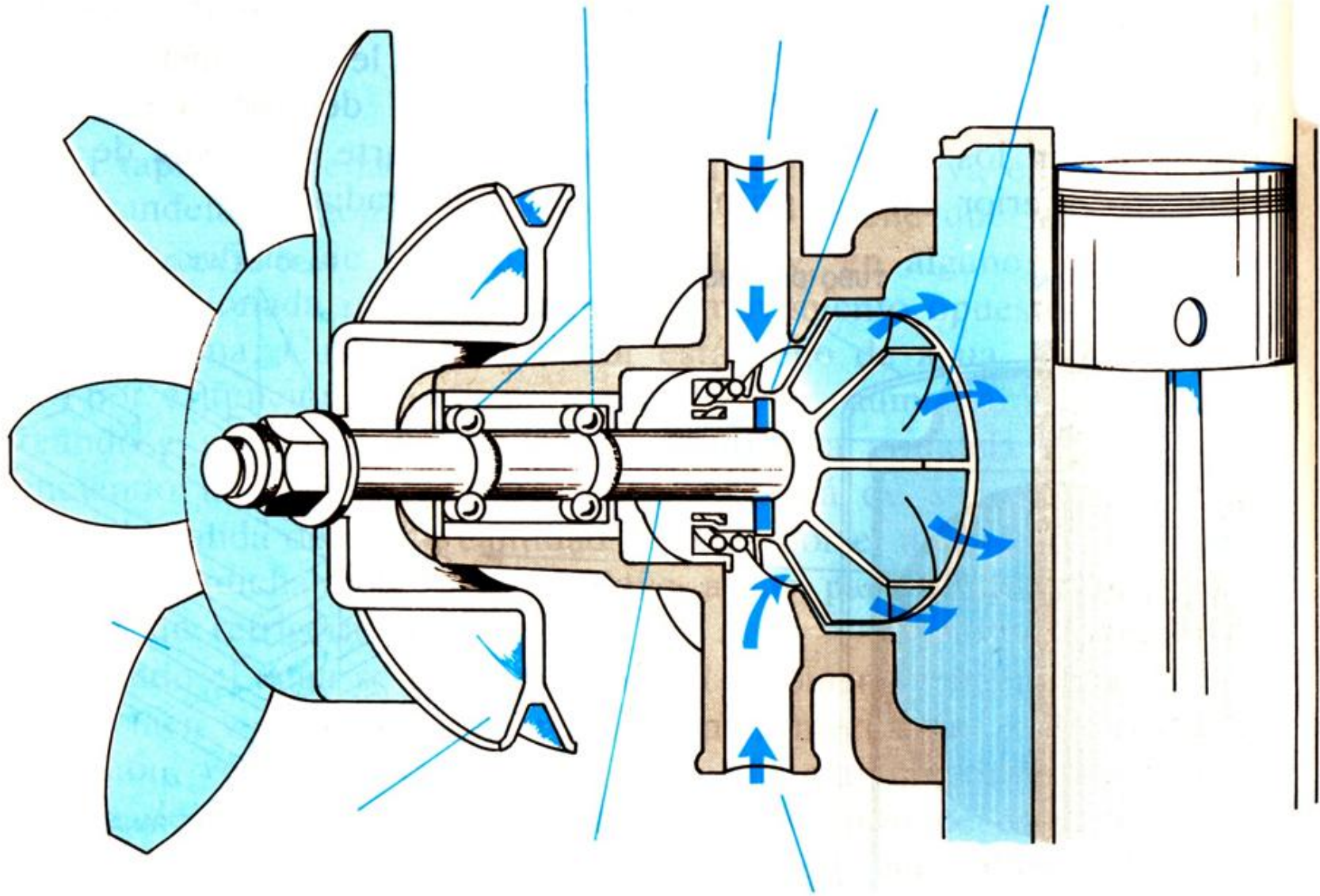



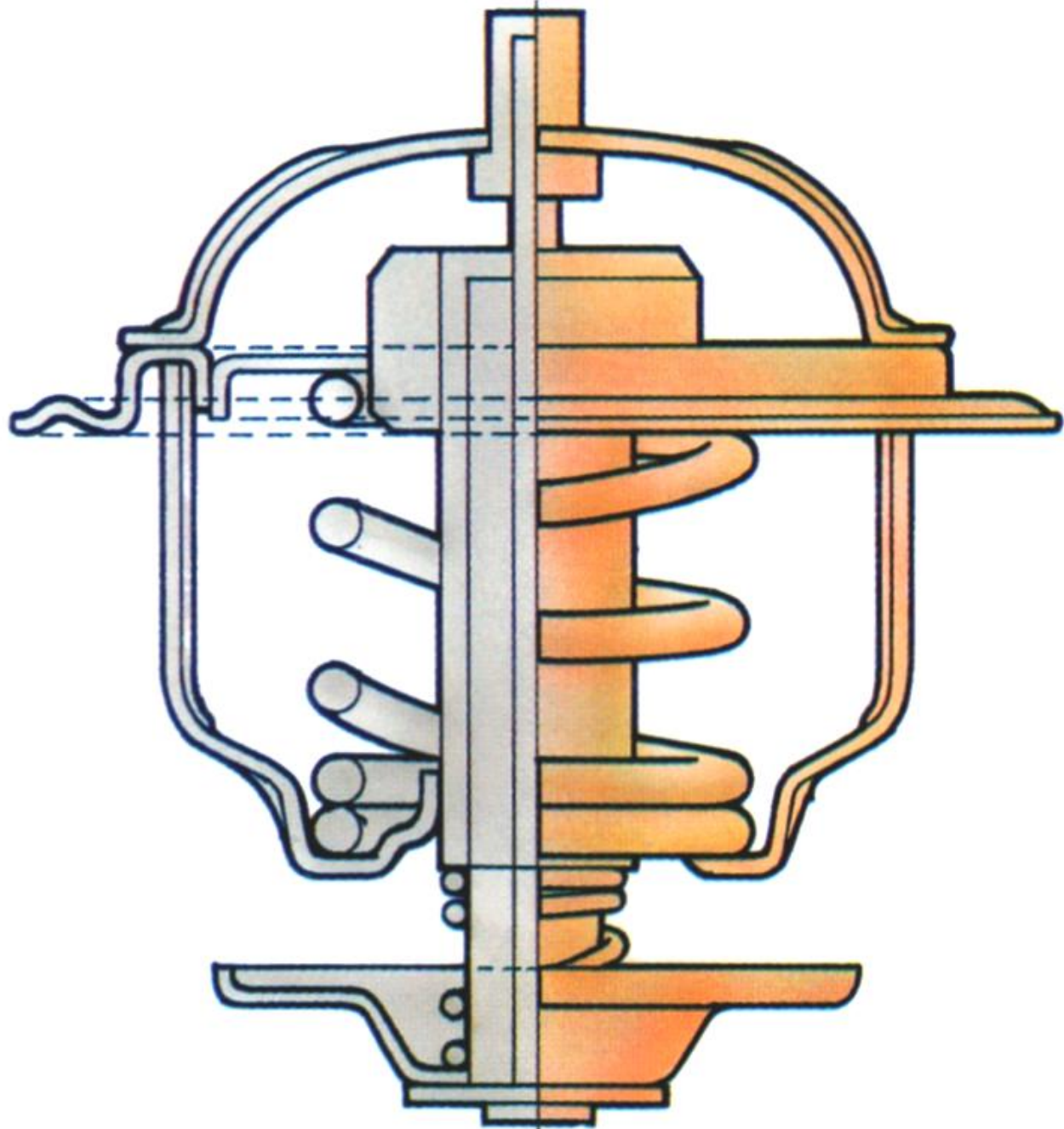

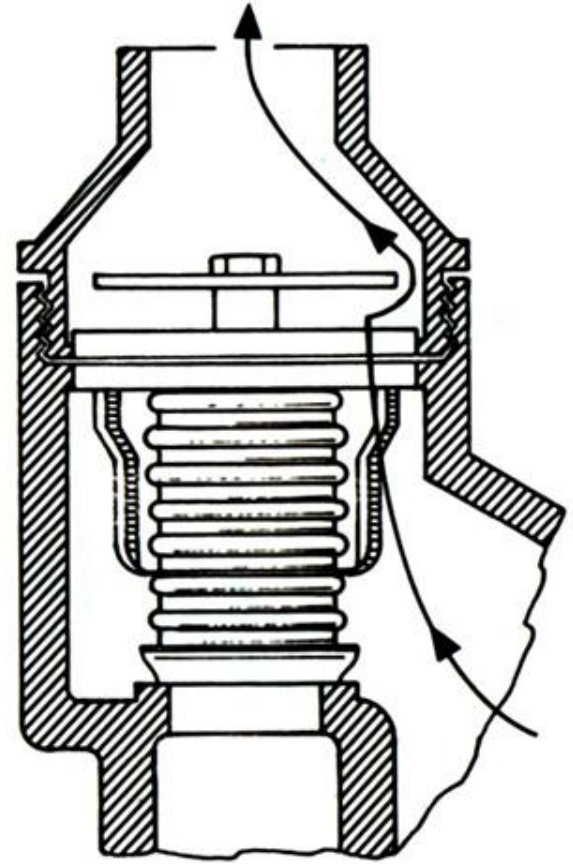
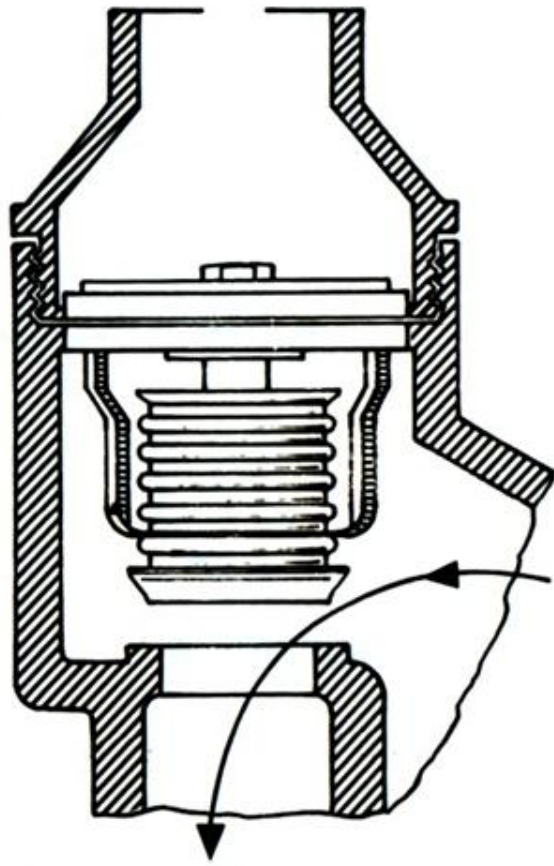



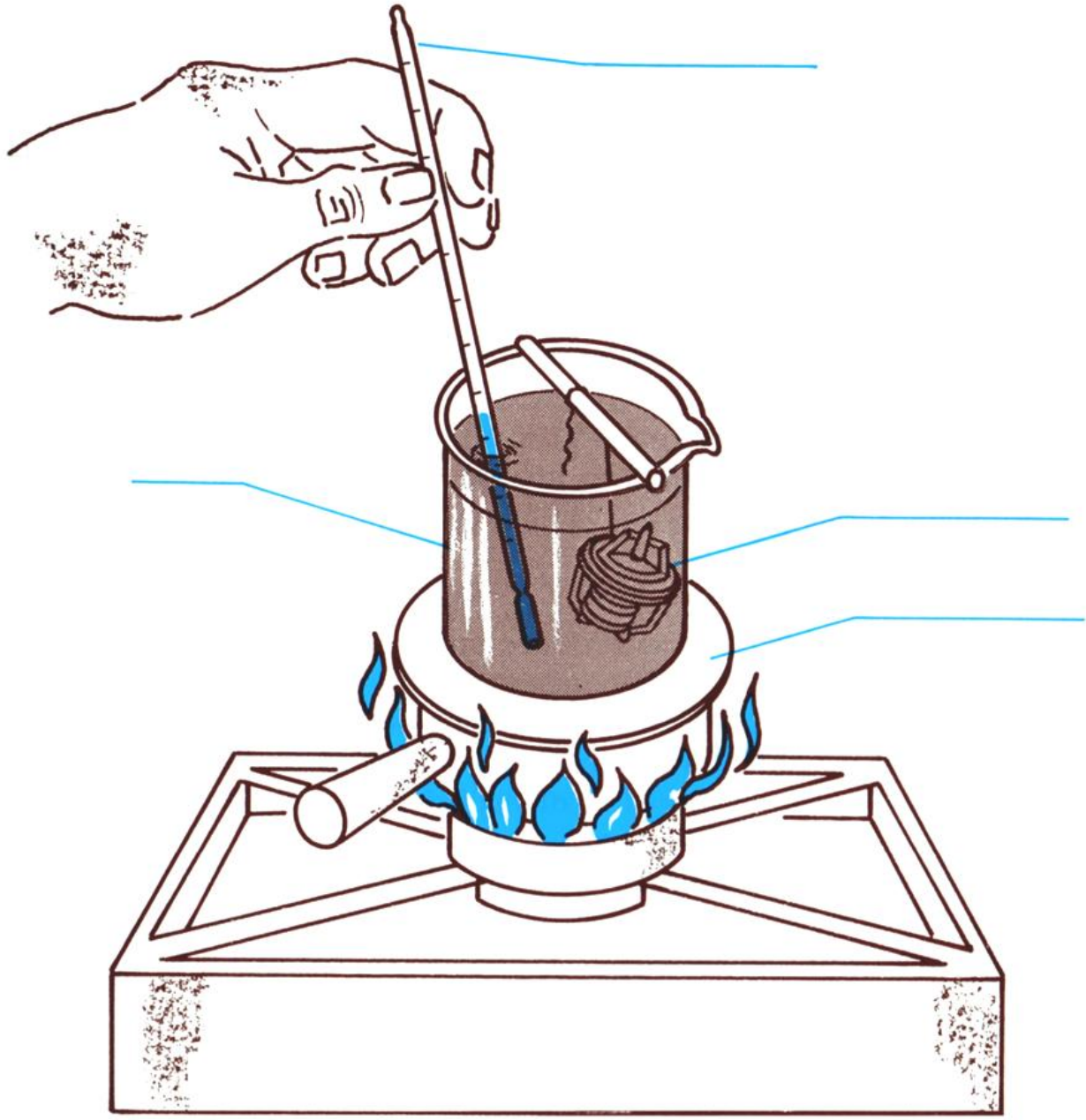

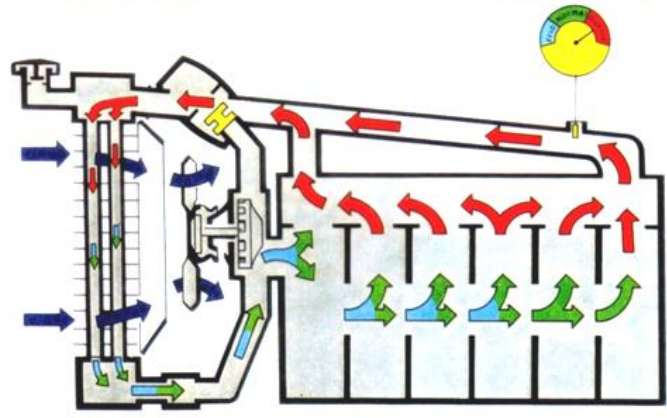
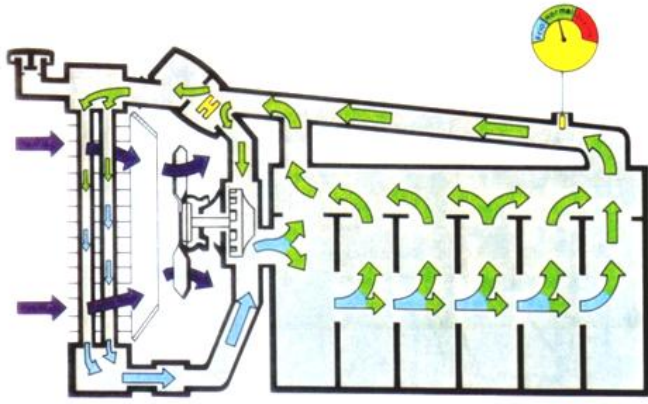
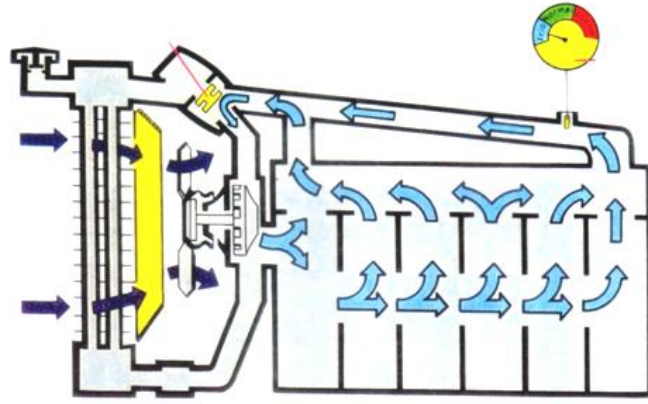

# Fluidos utilizados num motor de combustão interna

## **1) Combustível**

**-Utilize combustível de boa qualidade e procedência confiável**

## **2) Óleo**

**-O óleo deve estar dentro da qualidade e especificações determinadas pelo fabricante**

## **3) Líquido de arrefecimento**

**-Deve se respeitar a proporção mínima de líquido especificada pelo fabricante**

## **4) Ar**

**- Mantenha a manutenção dos filtro em dia, respeitando os intervalos de troca -especificados pelo fabricante.**

**-Sempre observe o indicador de restrição do filtro de ar.**

**-O filtro de ar obstruído causa perda de desempenho, aumento de consumo e elevados níveis de fumaça.**

# Componentes de um motor eletrônico

